

CDBMT220-HF Thru. CDBMT2100-HF

Reverse Voltage: 20 to 100 Volts

Forward Current: 2.0 Amp

RoHS Device
Halogen Free

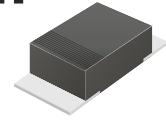

Features

- Excellent power dissipation offers better reverse leakage current and thermal resistance.
- Low profile package is 40% thinner than standards SOD-123.
- Low power loss,high efficiency.
- High current capability,low forward voltage drop.
- High surge capability.
- Guarding for overvoltage protection.
- Ultra high-speed switching.
- Silicon epitaxial planar chip,metal silicon junction.
- Lead-free part meets environmental standards of MIL-STD-19500/228

Mechanical data

- Epoxy: UL94-V0 rated flame retardant.
- Case: Molded plastic, SOD-123H/MINI SMA
- Terminals: Solderable per MIL-STD-750, Method 2026.
- Polarity: Indicated by cathode band.
- Mounting Position: any
- Weight: 0.011 grams approx.

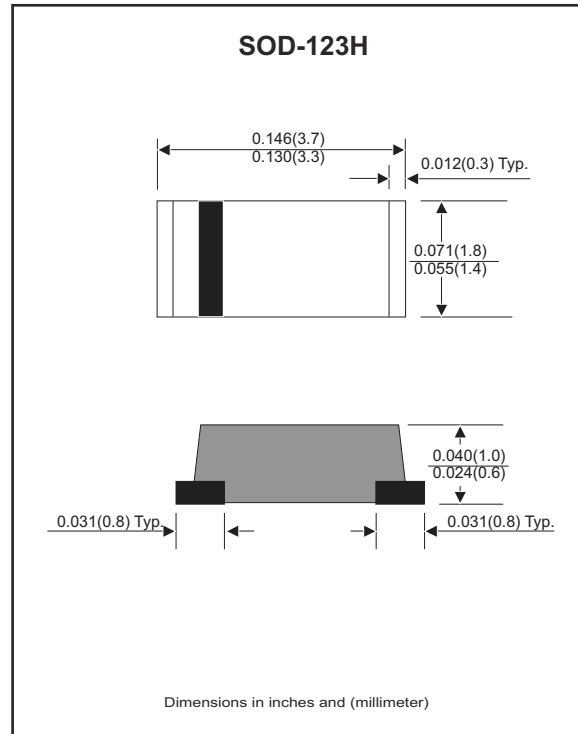

Maximum Ratings (at T_A=25°C unless otherwise noted)

Parameter	Symbol	CDBMT 220-HF	CDBMT 230-HF	CDBMT 240-HF	CDBMT 250-HF	CDBMT 260-HF	CDBMT 280-HF	CDBMT 2100-HF	Unit
Repetitive peak reverse voltage	V _{RRM}	20	30	40	50	60	80	100	V
Continuous reverse voltage	V _R	20	30	40	50	60	80	100	V
RMS voltage	V _{RMS}	14	21	28	35	42	56	70	V
Forward rectified current	I _O	2.0							A
Maximum forward voltage @ I _F =2.0A	V _F	0.50			0.70		0.85		V
Max. Forward surge current 8.3ms single half sine-wave superimposed on rated load (JEDEC method)	I _{FSM}	50							A
Max.Reverse current	V _R =V _{RRM} T _J =25°C	0.5							mA
	V _R =V _{RRM} T _J =100°C	10							
Typ. Thermal resistance (Junction to ambient)	R _{θJA}	85							°C/W
Typ. Diode Junction capacitance (Note 1)	C _J	160							pF
Operating temperature	T _J	-55 to +125			-55 to +150				°C
Storage temperature range	T _{STG}	-65 to +175							°C

Note : 1. F=1MHz and applied 4V DC reverse voltage

Rating and Characteristic Curves (CDBMT220-HF Thru. CDBMT2100-HF)

Fig.1- Typical Forward Current Derating Curve

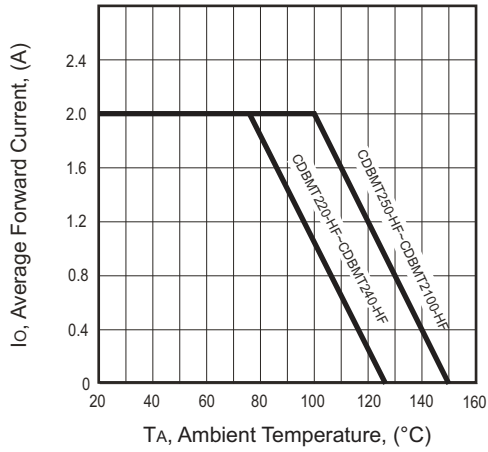

Fig.2 - Typical Forward Characteristics

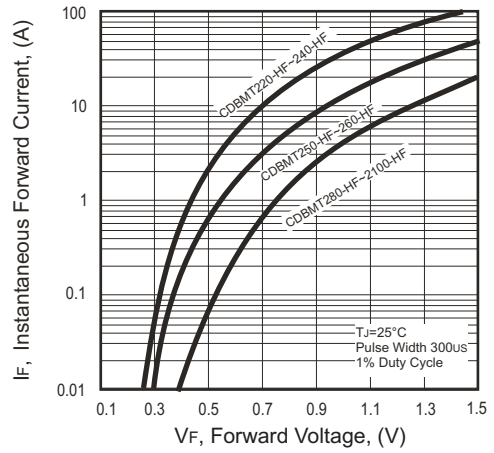

Fig.3 - Maximum Non-repetitive Forward Surge Current

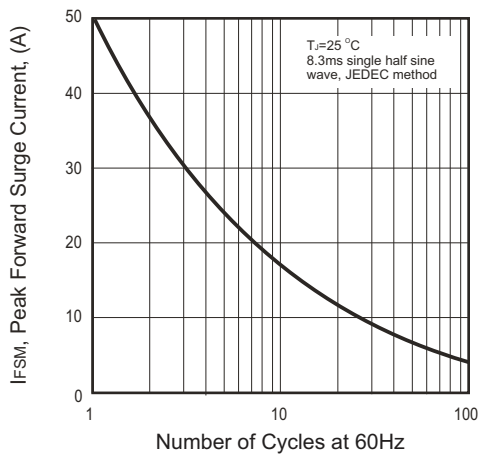

Fig.4 - Typical Junction Capacitance

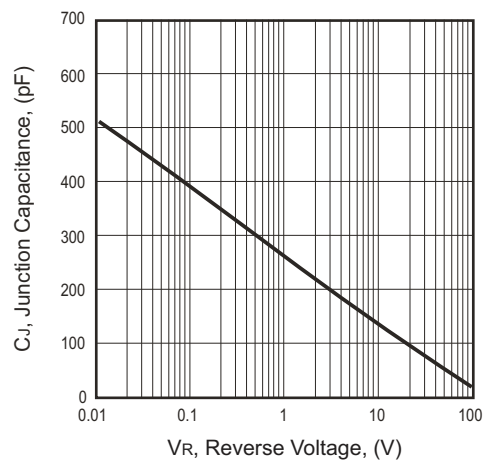
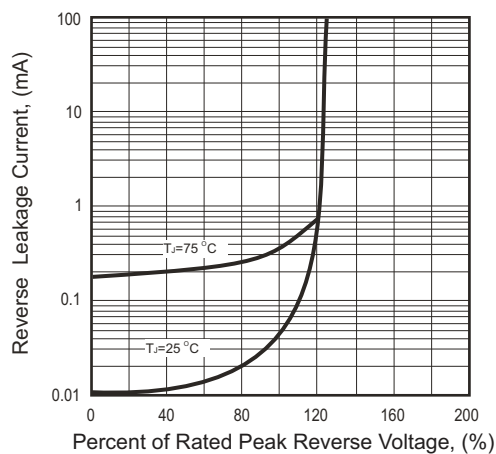
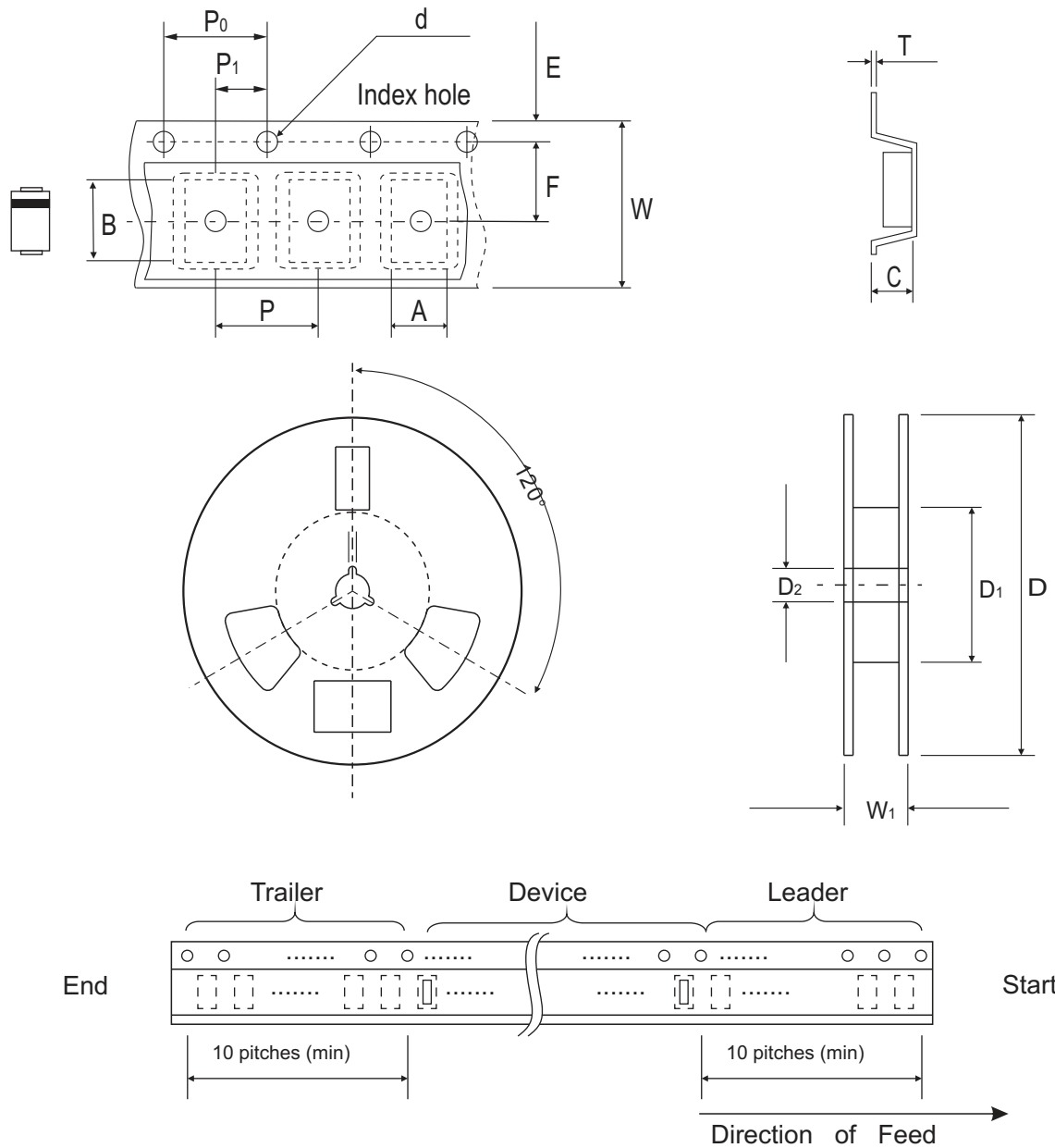

Fig.5 - Typical Reverse Characteristics



Reel Taping Specification



SOD-123H	SYMBOL	A	B	C	d	D	D1	D2
	(mm)	2.00 ± 0.10	3.85 ± 0.10	1.10 ± 0.10	1.50 ± 0.10	178 ± 2.00	62.0 MIN.	13.0 ± 0.50
	(inch)	0.079 ± 0.004	0.152 ± 0.004	0.043 ± 0.004	0.059 ± 0.004	7.00 ± 0.079	2.440 MIN.	0.512 ± 0.020

SOD-123H	SYMBOL	E	F	P	P0	P1	T	W	W1
	(mm)	1.75 ± 0.10	3.50 ± 0.10	4.00 ± 0.10	4.00 ± 0.10	2.00 ± 0.10	0.23 ± 0.10	8.00 ± 0.30	11.40 ± 1.0
	(inch)	0.069 ± 0.004	0.138 ± 0.004	0.157 ± 0.004	0.157 ± 0.004	0.079 ± 0.004	0.009 ± 0.004	0.315 ± 0.012	0.449 ± 0.039

Pinning information

Pin	Simplified outline	Symbol
PIN 1 Cathode PIN 2 Anode		

Marking Code

Part Number	Marking Code
CDBMT220-HF	22
CDBMT230-HF	23
CDBMT240-HF	24
CDBMT250-HF	25
CDBMT260-HF	26
CDBMT280-HF	28
CDBMT2100-HF	20



xx / xxx = Product type marking code

Suggested PAD Layout

SIZE	SOD-123H	
	(mm)	(inch)
A	3.00	0.118
B	1.30	0.051
C	1.80	0.071
D	4.30	0.169
E	1.70	0.067

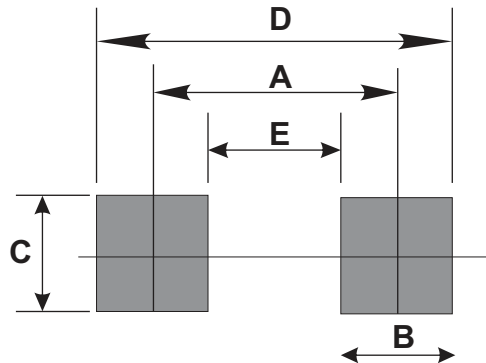

Standard Packaging

Case Type	REEL PACK	
	REEL (pcs)	Reel Size (inch)
SOD-123H	3,000	7