

T H E R M O M E T R I C S  
A C O M M I T M E N T T O E X C E L L E N C E

# ZTP-315

## Thermometrics Thermopile IR Sensor



The ZTP-315 thermopile IR sensor is used for non-contact surface temperature monitoring. The ZTP-315 model consists of thermoelements, a flat IR filter, a thermistor for temperature compensation and a hermetically-sealed small-size package. There is also a variety of filters available to maximize performance in specific applications.

### Applications

- HVAC
- Occupancy detection
- Automotive

### Features

- Non-contact measurement
- Wider surface area measurement
- Small-size sensor package
- Included ambient temperature (thermistor) sensor for compensation
- High sensitivity
- Fast response time
- Low cost

**Amphenol**  
**Advanced Sensors**

## Thermopile Chip

Parameter	Limits			Units	Condition
	Min	Typ	Max		
Chip Size		3.6 × 3.6		mm <sup>2</sup>	
Diaphragm Size		2.6 × 2.6		mm <sup>2</sup>	
Active Area		1.3 × 1.3		mm <sup>2</sup>	
Internal Resistance	35	50	65	kΩ	25 °C
Resistance T.C.			0.12	%/°C	
Responsivity	22	32	42	V/W	500K, 1Hz
Responsivity T.C.		-0.11		%/°C	
Noise Voltage		30		nV rms	R.M.S., 25 °C
NEP		0.94		nW/Hz <sup>1/2</sup>	500K, 1 Hz
Detectivity		1.38 E08		cmHz <sup>1/2</sup> /W	500K, 1 Hz
Time Constant		25		ms	

## Thermistor

Parameter	Limits			Units	Condition
	Min	Typ	Max		
Resistance	29.7	30	30.3	kΩ	Tol.:1%, @25 °C
Beta - Value	3773	3811	3849	K	Tol.:1%, Defined at @25 °C/50 °C

## Absolute Maximum Ratings

### Operating Temperature

-20°C ~ 100°C

### Storage Temperature

-40°C ~ 120°C

## Thermistor Resistance (R-T Table)

Tamb (°C)	Rmin (kΩ)	Rcent (kΩ)	Rmax (kΩ)
-40	847.1	885.1	924.7
-35	624.1	650.2	677.2
-30	464.0	481.9	500.5
-25	348.0	360.3	373.1
-20	263.1	271.7	280.5
-15	200.6	206.5	212.7
-10	154.1	158.3	162.5
-5	119.3	122.2	125.2
0	93.03	95.06	97.12
5	73.07	74.48	75.91
10	57.78	58.76	59.75
15	46.00	46.67	47.34
20	36.85	37.30	37.76
25	29.70	30.00	30.30
30	23.98	24.27	24.57
35	19.47	19.75	20.03
40	15.89	16.15	16.42
45	13.04	13.28	13.53
50	10.76	10.98	11.20
55	8.914	9.112	9.314
65	6.202	6.362	6.526
70	5.204	5.348	5.495
75	4.383	4.512	4.644
80	3.704	3.820	3.938
85	3.141	3.244	3.350
90	2.670	2.763	2.858
95	2.277	2.359	2.444
100	1.946	2.019	2.095
105	1.667	1.732	1.800
110	1.430	1.489	1.550
115	1.230	1.282	1.336
120	1.058	1.105	1.153

## Typical Characteristic Data

### Sensitivity

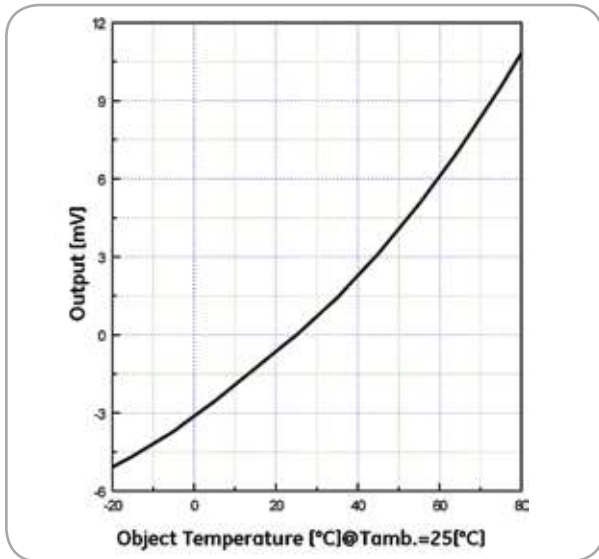

### Filter Transmission Data

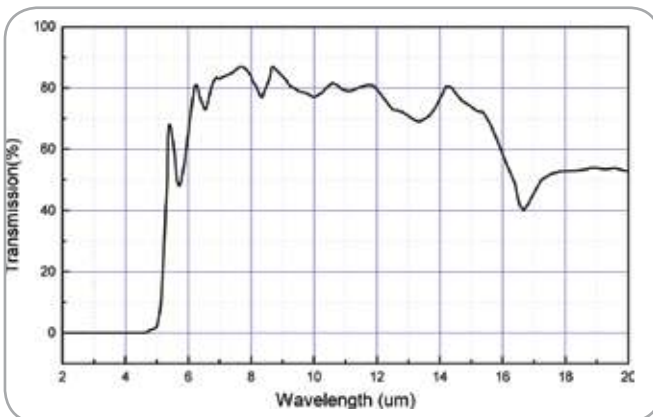

### Field of View

Parameter	Limits			Units	Condition
	Min	Typ	Max		
Field of View	70	75	80	Degree	50% of Maximum Output

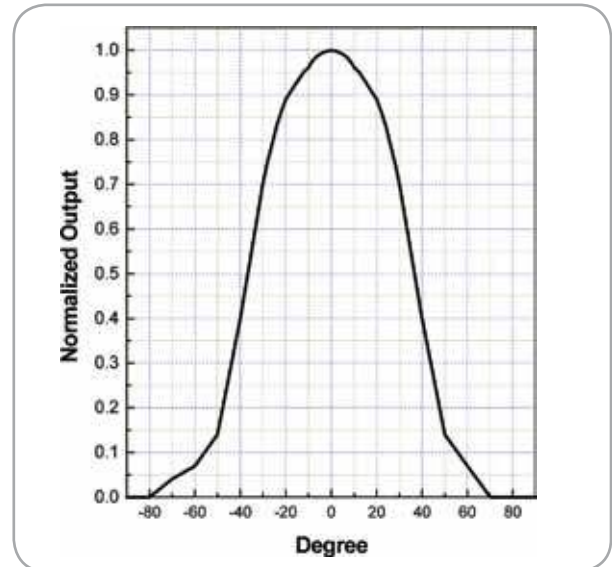

# Outline of Sensor Package and Pin Arrangement [unit: mm]

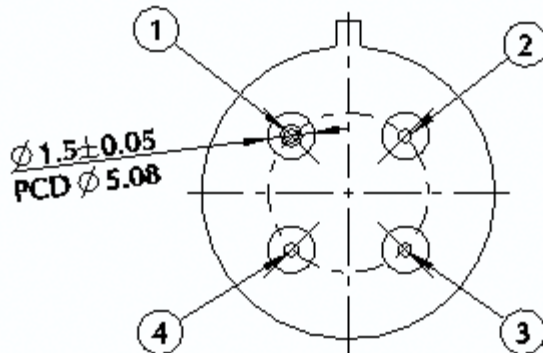
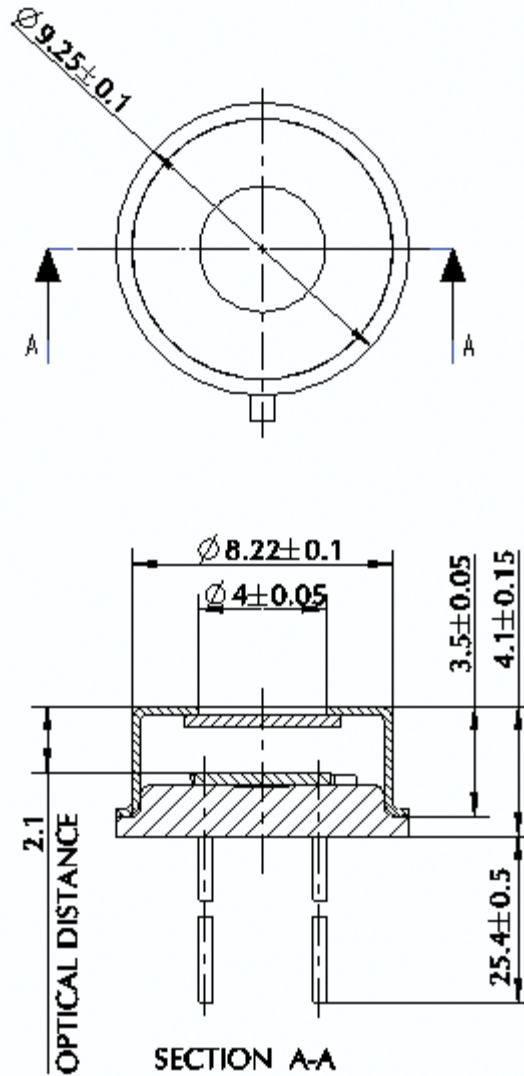

## Pin Arrangement

1. GND Thermistor
2. Thermopile
3. Thermistor
4. GND Thermopile

**Amphenol**  
Advanced Sensors

[www.amphenol-sensors.com](http://www.amphenol-sensors.com)

© 2014 Amphenol Corporation. All Rights Reserved. Specifications are subject to change without notice. Other company names and product names used in this document are the registered trademarks or trademarks of their respective owners.