

VIEW Z-Z

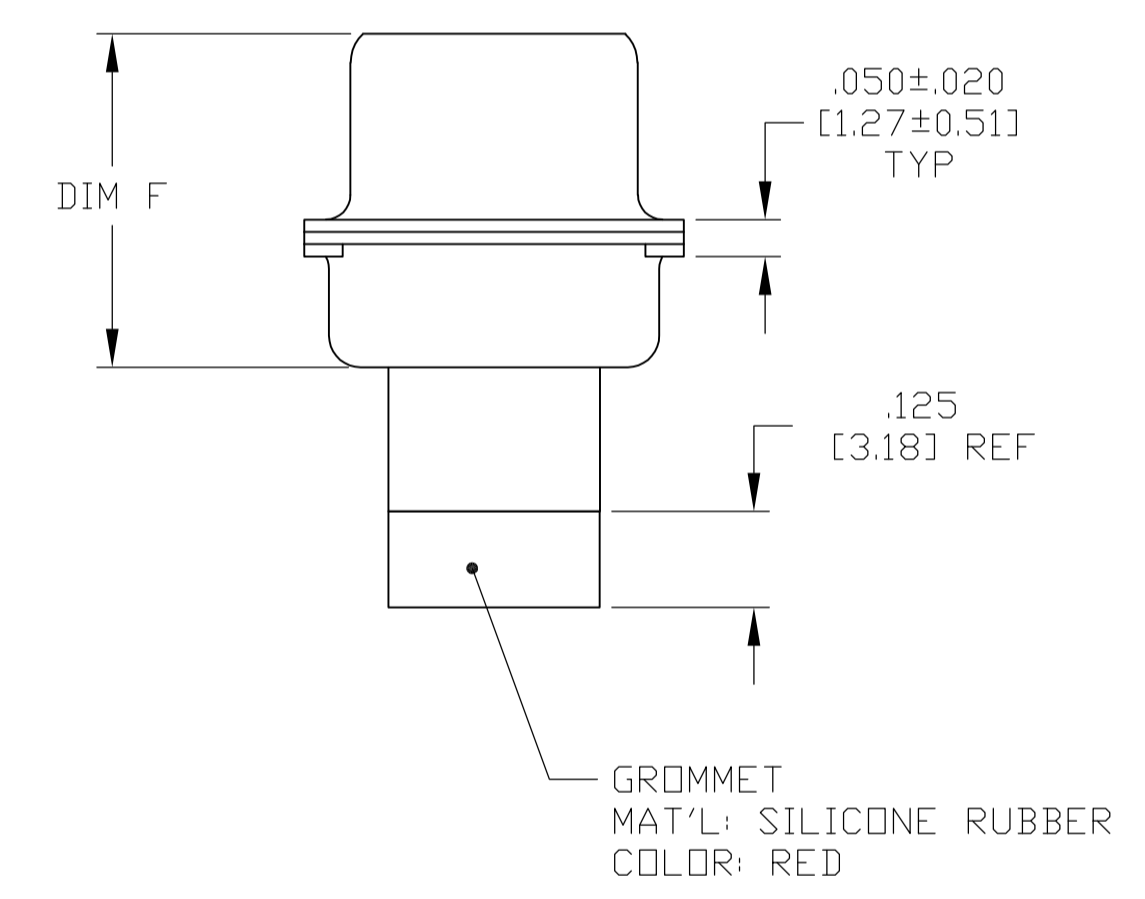
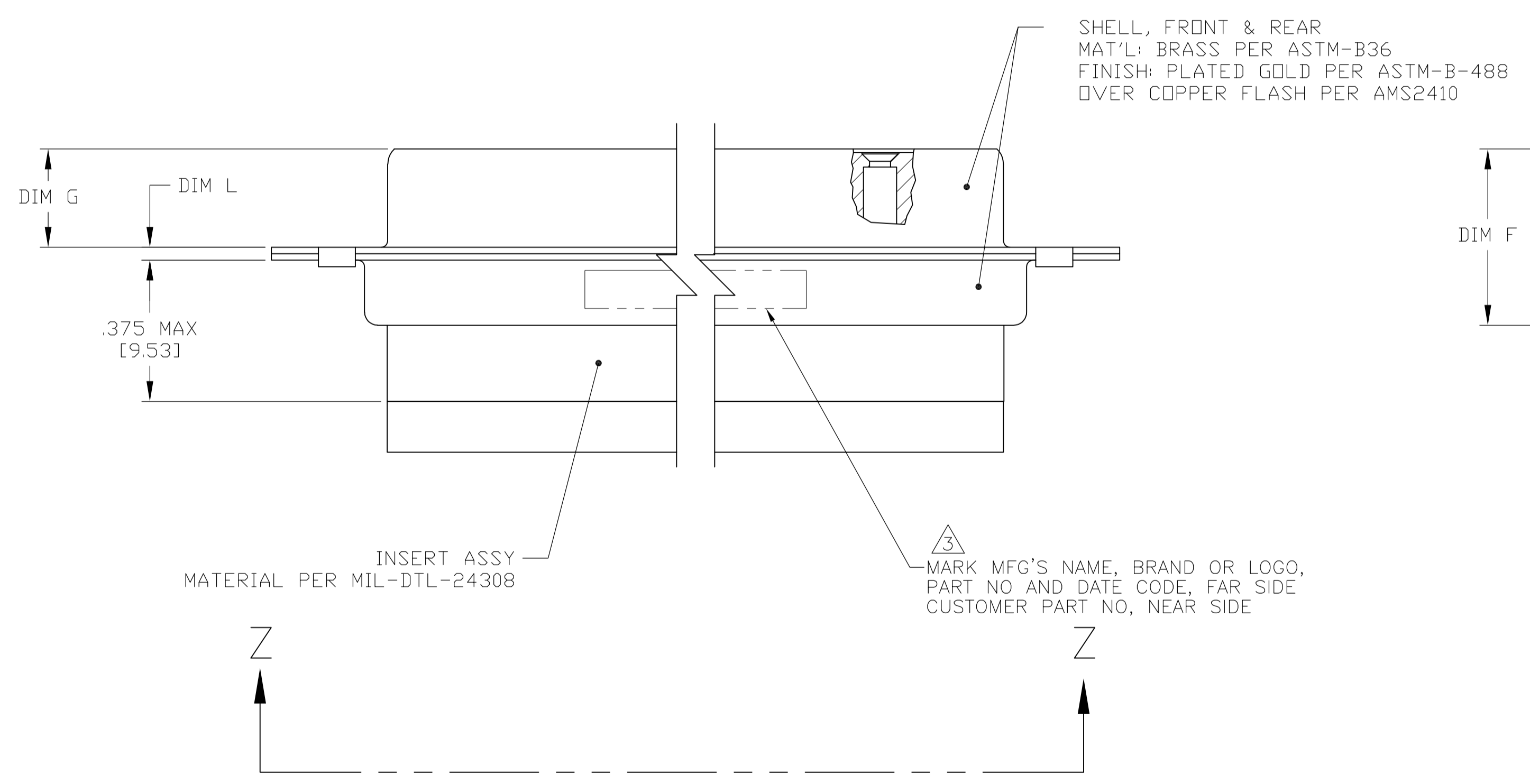

- THIS CONNECTOR ASSEMBLY IS SUPPLIED WITH Be Cu CONTACT RETENTION CLIPS INSTALLED IN THE INSERT ASSEMBLY.
- THIS CONNECTOR ASSEMBLY MATES WITH ANY PLUG CONNECTOR WITH THE SAME INSERT ARRANGEMENT AND DIMENSIONAL REQUIREMENTS PER MIL-C-24308.
- MARKED WITH .047 [1.19]-.062 [1.57] HIGH CHARACTERS. FAR SIDE REFERS TO THE WIDE SIDE OF THE KEYSTONE. NEAR SIDE REFERS TO THE NARROW SIDE OF THE KEYSTONE.
- MAXIMUM WIRE INSULATION TO BE USED WITH THIS CONNECTOR ASSEMBLY IS .068 [1.73] DIAMETER.
- SPECIAL REQUIREMENTS PER BDEING 1A01 DOCUMENT.
- BUILT TO ORDER, NO INVENTORY OF THIS PART NUMBER IS TO BE KEPT. SINGLE LOT DATE CODE REQUIRED.

		1A01-023RHW	.049 [1.24] .029 [0.74]	.432 [10.97] .412 [10.46]	1.635 [41.53] 1.615 [41.02]	.248 [6.30] .238 [6.05]	.439 [11.15] .419 [10.64]	.509 [12.93] .479 [12.17]	.316 [8.03] .306 [7.77]	1.857 [47.17] 1.847 [46.91]	1.516 [38.51] 1.506 [38.25]	2.103 [53.42] 2.073 [52.65]	MS18275-1	25	3	1-211635-1
--	--	---	.049 [1.24] .029 [0.74]	.432 [10.97] .412 [10.46]	1.635 [41.53] 1.615 [41.02]	.248 [6.30] .238 [6.05]	.439 [11.15] .419 [10.64]	.509 [12.93] .479 [12.17]	.316 [8.03] .306 [7.77]	1.857 [47.17] 1.847 [46.91]	1.516 [38.51] 1.506 [38.25]	2.103 [53.42] 2.073 [52.65]	MS18275-1	25	3	211635-4
		1A01-023RHA	.049 [1.24] .029 [0.74]	.432 [10.97] .412 [10.46]	1.635 [41.53] 1.615 [41.02]	.248 [6.30] .238 [6.05]	.439 [11.15] .419 [10.64]	.509 [12.93] .479 [12.17]	.316 [8.03] .306 [7.77]	1.857 [47.17] 1.847 [46.91]	1.516 [38.51] 1.506 [38.25]	2.103 [53.42] 2.073 [52.65]	MS18275-1	25	3	211635-1
REMARKS	CUSTOMER MARKING		L	J	H	G	F	E	D	C	B	A	INSERT ARRANGEMENT	NO OF POS	SHELL SIZE	PART NUMBER

THIS DRAWING IS A CONTROLLED DOCUMENT.

DIMENSIONS: INCHES	TOLERANCES UNLESS OTHERWISE SPECIFIED:	DIN C.C.THOMAS 3-26-07	STE TE Connectivity
	0 PLC ± -	CHK D.MILLER 3-27-07	RECEPTACLE ASSEMBLY, AMPLIMITE, 25 POSITION, SIZE 3, SERIES 109, NON-MAGNETIC
	1 PLC ± -	APP'D D.MILLER 3-27-07	NAME
	2 PLC ± -	PRODUCT SPEC	APPLICATION SPEC
	3 PLC ± .005 [0.13]	SIZE	CAGE CODE
	4 PLC ± -	WEIGHT	DRAWING NO
ANGLES ± 1°	FINISH SEE CALLOUTS	CUSTOMER DRAWING	RESTRICTED TO
MATERIAL SEE CALLOUTS		SCALE 4:1	SHEET 1 OF 1
		REV P	