

NOTES:

1. MATERIAL:
 - CAGE: NICKEL SILVER
 - GASKET FLANGE: STAINLESS STEEL
 - EMI SPRINGS: COPPER ALLOY
 - LIGHT PIPES: POLYCARBONATE 94V-0(OPTIONAL)
 - GASKET - CORE MATERIAL 94V-0
 - CONNECTOR HOUSING: GLASS FILLED THERMOPLASTIC, UL: 94V-0. COLOR: BLACK
 - TERMINALS: HIGH PERFORMANCE COPPER ALLOY
 - ELASTOMERIC GASKET: SILVER IMPREGNATED SILICONE
2. FINISH:
 - CAGE & GASKET FLANGE: UNPLATED
 - EMI SPRINGS: 2.54µm NICKEL OVERALL
 - TERMINALS: CONTACT AREA: 0.76 µm MIN. HARD GOLD OVER 3.8 µm MIN. NICKEL.
 - COMPLIANT TAIL: 0.7 - 1.5 µm MATTE TIN OVER 0.7 - 1.5 µm NICKEL
3. PACKAGING: PRODUCT PACKAGED IN TRAYS AND CARTONS
4. ALL VISIBLE EXTERIOR SURFACES TO BE CLASS "B" OR BETTER, EXCEPT FOR UNDERSIDE OF THE CAGE WHICH IS CLASS "C" AND THE FRONT SURFACE OF THE MIDSECTION EMI SHIELD WHICH IS TO BE A CLASS "A" SURFACE, AND ARE ALL TO CONFORM TO THE MOLEX COSMETIC SPEC ES-171233-0001.
5. CONNECTOR MATES WITH PLUG CABLE SERIES 74757 AND 74758
6. DATE CODE LOCATION SHOWN, DATE CODE FORMAT:DDD Y= YEAR
DDD= DAY OF THE YEAR Y= YEAR

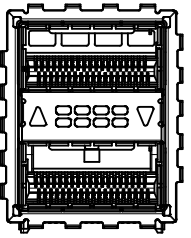

76871-1108 SHOWN W/O GASKET, SEE SHEET 2 FOR OTHER OPTIONS

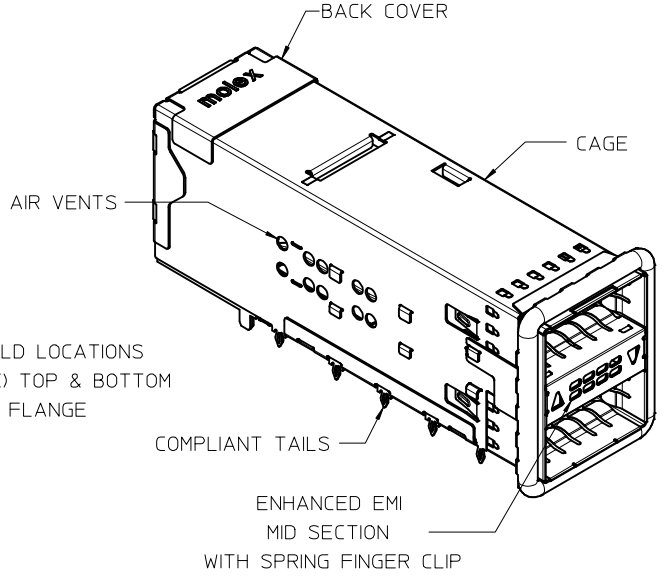
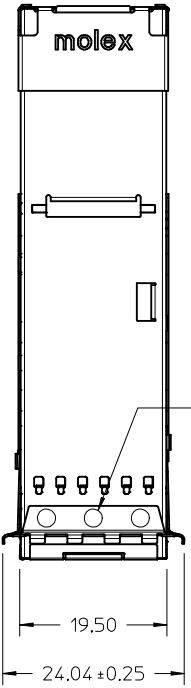
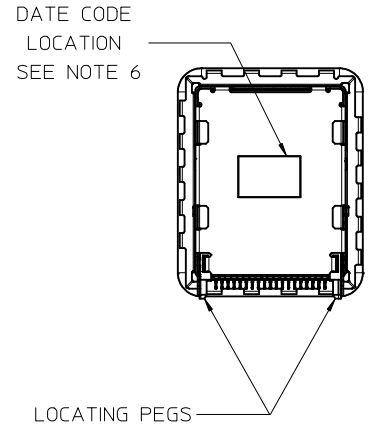
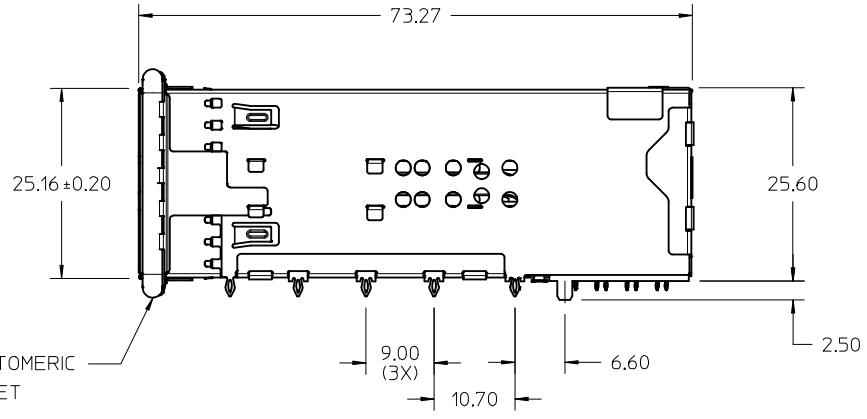

CORRECTED PIN #1 CALLOUT EC NO: UCP2014-4000 DRW: HWARY 2014/03/27 CHKD: MBANAKIS APPR: MBANAKIS 2014/03/31	QUALITY SYMBOLS ▽=0 ▽=0 ▽=0	GENERAL TOLERANCES (UNLESS SPECIFIED)		DIMENSION STYLE MM ONLY	SCALE 2:1	DESIGN UNITS METRIC	THIRD ANGLE PROJECTION		
		4 PLACES ± --- ± ---	3 PLACES ± --- ± ---	2 PLACES ± 0.13 ± ---	1 PLACE ± 0.25 ± ---	DRAWN BY JGONZALEZ01	DATE 2011/08/01	CHECKED BY KREGNIER	DATE 2011/08/01
		ANGULAR ± 1/2°				APPROVED BY MBANAKIS	DATE 2011/12/14	TITLE QSFP 2X1 ASSEMBLY ENHANCED MID SECTION & CLAW FLANGE	
		DRAFT WHERE APPLICABLE MUST REMAIN WITHIN DIMENSIONS				MATERIAL NO. SEE SHEET 2	DOCUMENT NO. SD-76871-1100	SHEET NO. 1 OF 3	

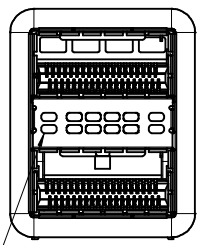

NO LIGHT PIPES
AIR FLOW VENTS
P/N: 76871-1105

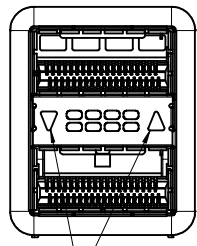

PORT ACTIVITY INDICATORS
LEFT DOWN / RIGHT UP
P/N: 76871-1106

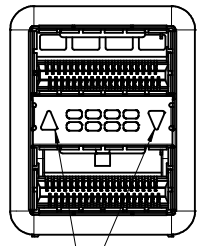

PORT ACTIVITY INDICATORS
LEFT UP / RIGHT DOWN
P/N: 76871-1108

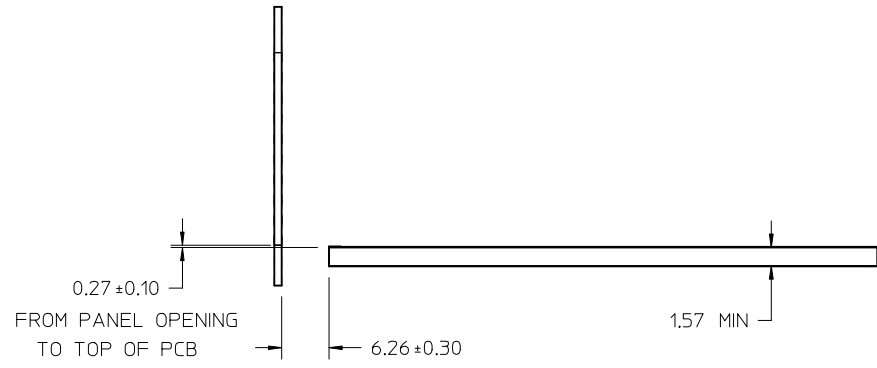
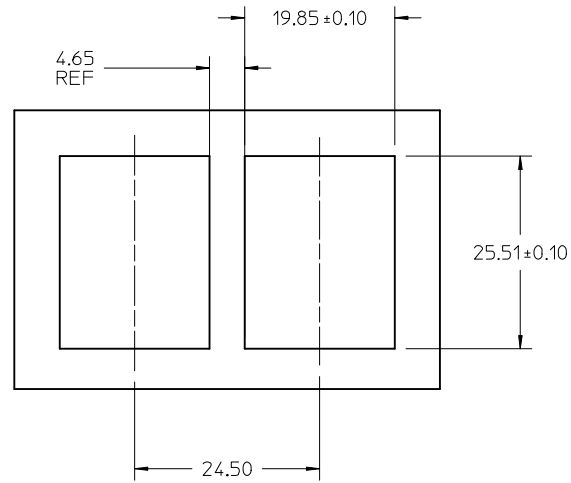

RECOMMENDED PANEL CUT-OUT

SEE SHEET 1 EC NO: UCP2014-4000 DRW: HAVERY 2014/03/27 CHKD: MBANAKIS APPR: MBANAKIS 2014/03/31	QUALITY SYMBOLS	GENERAL TOLERANCES (UNLESS SPECIFIED)		DIMENSION STYLE	SCALE	DESIGN UNITS	THIRD ANGLE PROJECTION
	▽=0	mm	INCH	MM ONLY	2:1	METRIC	
	▽=0	4 PLACES ± ---	± ---	DRAWN BY	DATE	TITLE	
	▽=0	3 PLACES ± ---	± ---	JGONZALEZ01	2011/08/01	QSFP 2X1 ASSEMBLY ENHANCED MID SECTION & CLAW FLANGE	
	2 PLACES ± 0.13	± ---	CHECKED BY	DATE	MOLEX INCORPORATED DOCUMENT NO. SD-76871-1100 SHEET NO. 2 OF 3		
	1 PLACE ± 0.25	± ---	KREGNIER	2011/08/01			
	ANGULAR ± 1/2°		APPROVED BY	DATE	THIS DRAWING CONTAINS INFORMATION THAT IS PROPRIETARY TO MOLEX INCORPORATED AND SHOULD NOT BE USED WITHOUT WRITTEN PERMISSION		
	DRAFT WHERE APPLICABLE MUST REMAIN WITHIN DIMENSIONS		MBANAKIS	2011/12/14			

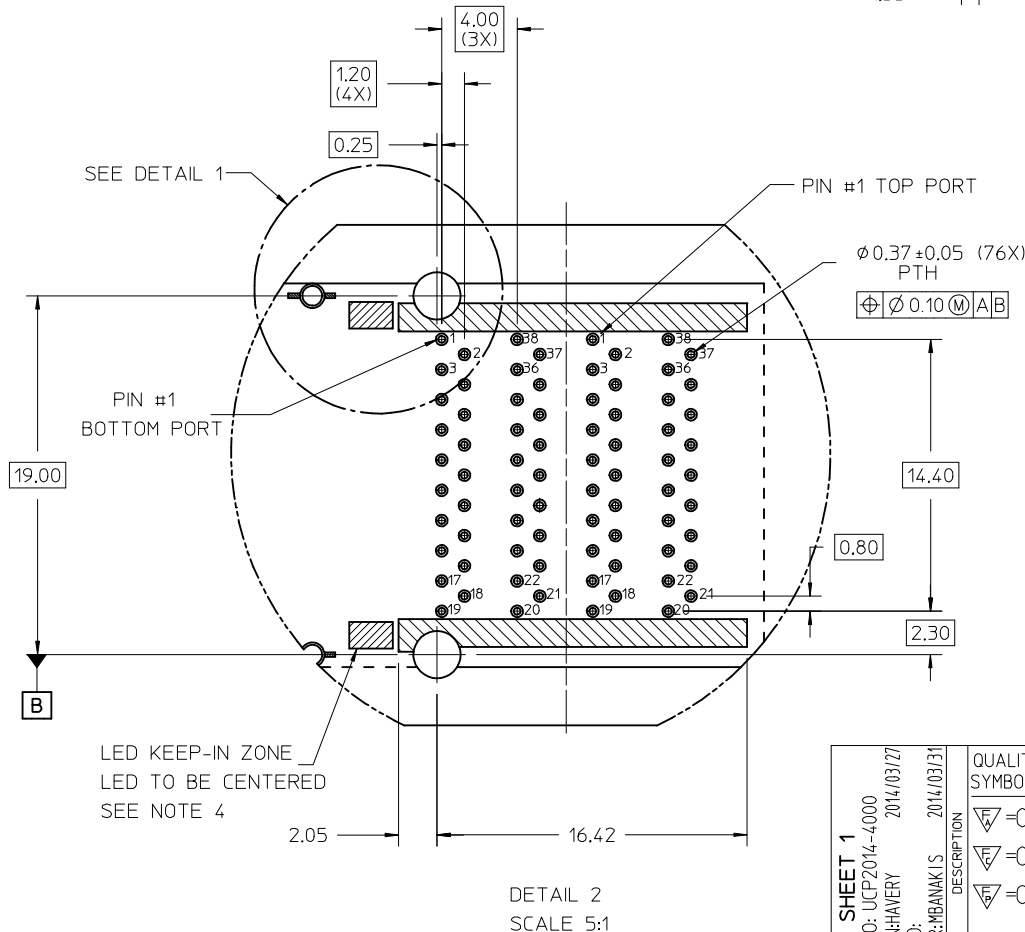
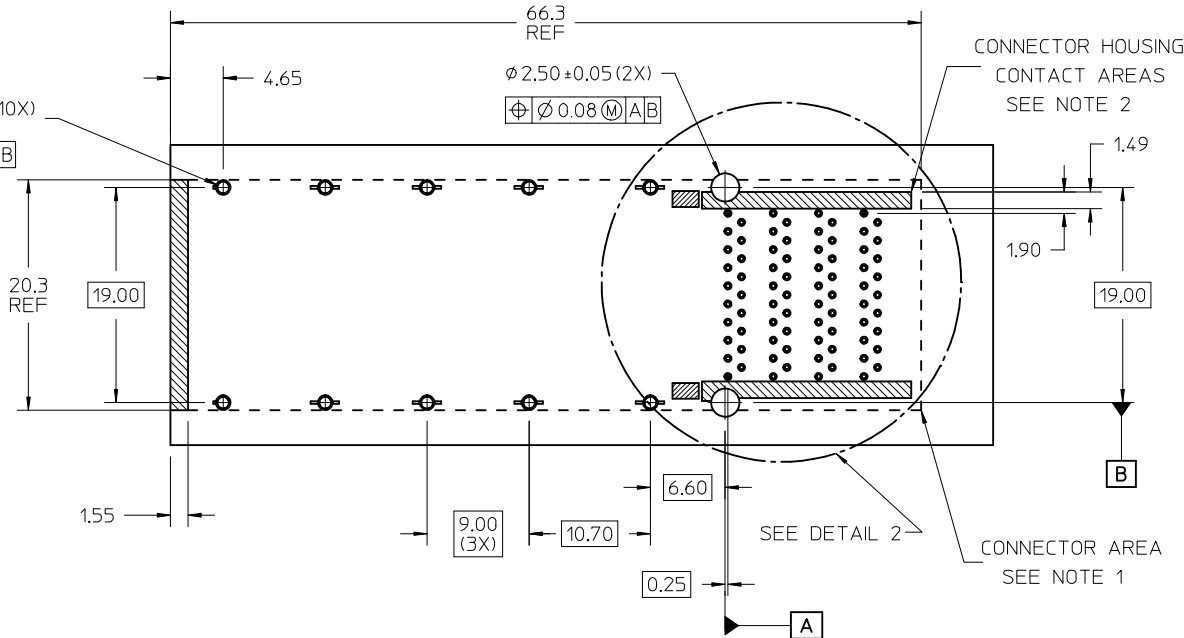
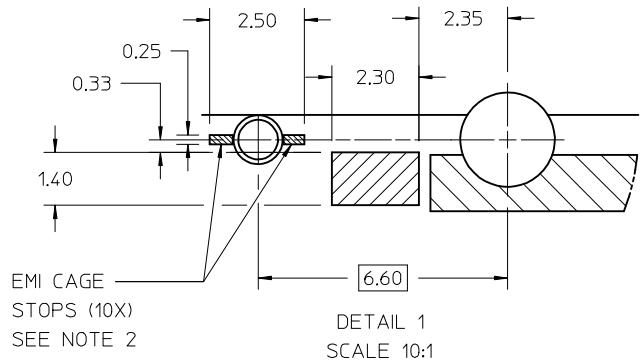

- NOTES:
1. THE ENTIRE AREA UNDER THE CONNECTOR (DASHED LINES) IS TO BE CONSIDERED A KEEP-OUT AREA FOR COMPONENTS.
 2. HATCHED AREAS REPRESENT ZONES ON THE PCB THAT COME IN CONTACT WITH OR BE IN CLOSE PROXIMITY TO THE PLASTIC HOUSING OR THE CONNECTOR CAGE. INDICATED AREAS TO BE CONSIDERED TRACE FREE.
 3. PIN NUMBERS ARE PER THE STANDARD. BOTH PORTS ARE IN THE SAME (UP-UP)MODULE ORIENTATION.
 4. LED KEEP-IN ZONE DEFINES THE PHYSICAL SPACE ALLOWED FOR PLACEMENT OF SMD CHIP STYLE LED PACKAGES INCLUDING SMD MOUNTING PADS. KEEP-IN ZONE EXTENDS VERTICALLY TO 0.8mm ABOVE THE TOP SIDE OF BOARD.
 5. SEE APPLICATION SPEC AS-76870-001 FOR RECOMMENDED DRILL HOLE SIZE.

SEE SHEET 1 EC NO: UCP2014-4000 DRAWN BY: DRWN:HAVERY 2014/03/27 CHKD: APPR:MBANAKIS 2014/03/31	QUALITY SYMBOLS	GENERAL TOLERANCES (UNLESS SPECIFIED)	DIMENSION STYLE MM ONLY	SCALE 3:1	DESIGN UNITS METRIC	THIRD ANGLE PROJECTION
	▽=0	mm INCH	DRAWN BY DATE JGONZALEZ01 2011/08/01	TITLE QSFP 2X1 ASSEMBLY ENHANCED MID SECTION & CLAW FLANGE	MOLEX INCORPORATED	
	▽=0	4 PLACES ± --- ± ---	CHECKED BY DATE KREGNIER 2011/08/01	APPROVED BY DATE MBANAKIS 2011/12/14		
	▽=0	3 PLACES ± --- ± ---	2 PLACES ± 0.13 ± ---	1 PLACE ± 0.25 ± ---	ANGULAR ± 1/2°	MATERIAL NO.
DRAFT WHERE APPLICABLE MUST REMAIN WITHIN DIMENSIONS		SEE SHEET 2		DOCUMENT NO. SD-76871-1100		
THIS DRAWING CONTAINS INFORMATION THAT IS PROPRIETARY TO MOLEX INCORPORATED AND SHOULD NOT BE USED WITHOUT WRITTEN PERMISSION						

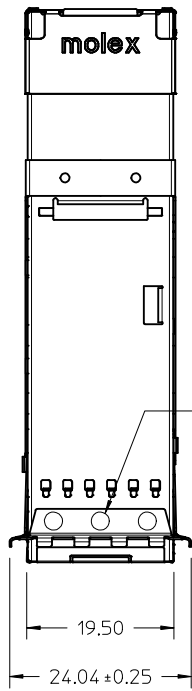

WELD LOCATIONS
(3X) TOP & BOTTOM
OF FLANGE

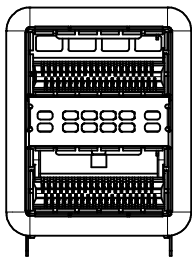
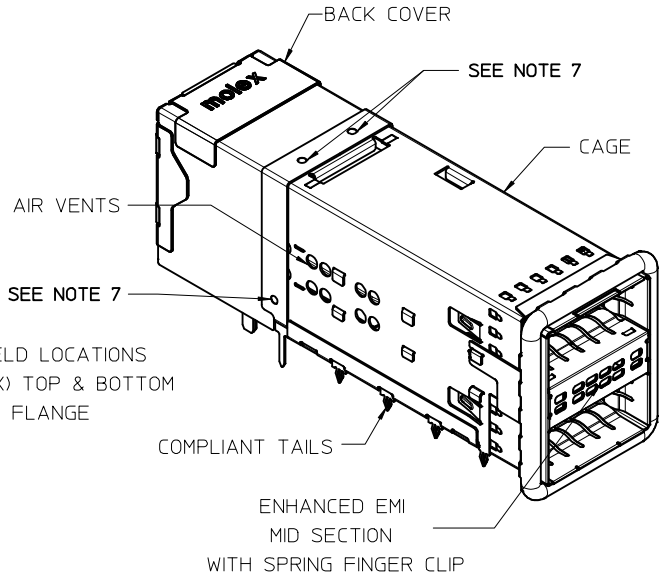

76871-1108 SHOWN
W/O GASKET, SEE
SHEET 2 FOR OTHER
OPTIONS

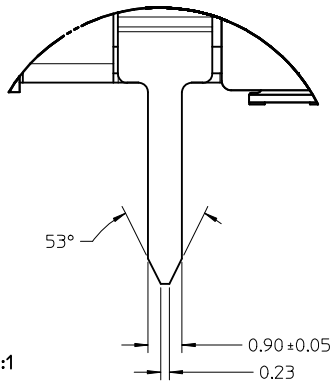

Detail 1
Scale 10:1

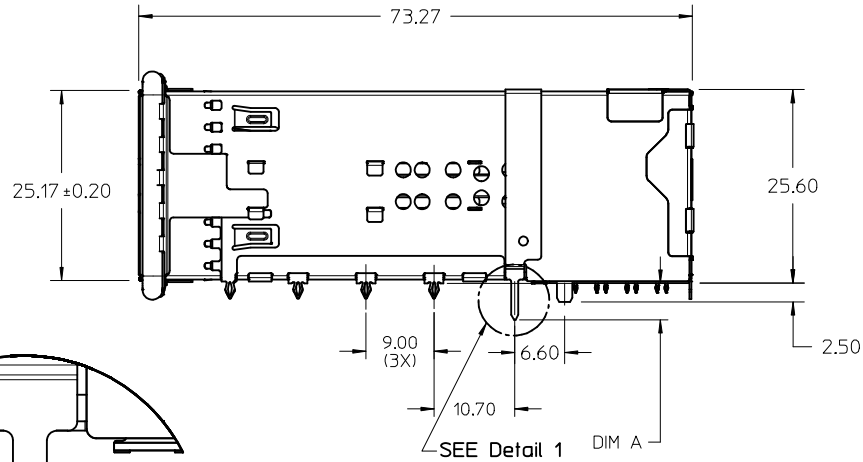

DATE CODE
LOCATION
SEE NOTE 6

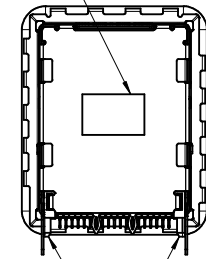

LOCATING PEGS

NOTES:

1. MATERIAL:

- CAGE AND SOLDER STRAP: NICKEL SILVER
- GASKET FLANGE: STAINLESS STEEL
- EMI SPRINGS: COPPER ALLOY
- LIGHT PIPES: POLYCARBONATE 94V-0(OPTIONAL)
- GASKET - CORE MATERIAL 94V-0
- CONNECTOR HOUSING: GLASS FILLED THERMOPLASTIC, UL: 94V-0, COLOR: BLACK
- TERMINALS: HIGH PERFORMANCE COPPER ALLOY

2. FINISH:

- CAGE, GASKET FLANGE, AND SOLDER STRAP: UNPLATED
- EMI SPRINGS: 2.5µm NICKEL OVERALL
- TERMINALS: CONTACT AREA: 0.76 µm MIN. HARD GOLD OVER 3.8 µm MIN. NICKEL.
- COMPLIANT TAIL: 0.7 - 1.5 µm MATTE TIN OVER 0.7 - 1.5 µm NICKEL

3. PACKAGING: PRODUCT PACKAGED IN TRAYS AND CARTONS

4. TOP AND SIDE SURFACES TO BE CLASS "B" OR BETTER. ALL REMAINING SURFACES TO BE CLASS "C" OR BETTER WITH THE EXCEPTION OF THE FRONT OF THE MIDSECTION EMI SPRING WHICH IS TO BE A CLASS "A" SURFACE AS DESCRIBED IN THE MOLEX ES-46030-006 COSMETIC SPEC.

5. CONNECTOR MATES WITH PLUG CABLE SERIES 74757 AND 74758

6. DATE CODE LOCATION SHOWN, DATE CODE FORMAT:DDD
DDD= DAY OF THE YEAR Y= YEAR

7. SOLDER STRAP TO BE LASER WELDED IN APPROXIMATE LOCATIONS SHOWN.

UPDATED COSMETIC SPEC NUMBER EC NO: UCP2014-1269 DRWN:HIVERY 2013/08/02 CHKD: MBANAKIS 2013/10/08 APPR:MBANAKIS 2013/10/08	QUALITY SYMBOLS ∇=0 ∇=0 ∇=0	GENERAL TOLERANCES (UNLESS SPECIFIED)		DIMENSION STYLE MM ONLY	SCALE 2:1	DESIGN UNITS METRIC	THIRD ANGLE PROJECTION
		4 PLACES ± --- ± --- 3 PLACES ± --- ± --- 2 PLACES ± 0.13 ± --- 1 PLACE ± 0.25 ± --- ANGULAR ± 1/2°	mm INCH	DRAWN BY DATE HIVERY 2013/01/31	TITLE QSFP 2X1 ASSEMBLY WITH SOLDER STRAP	APPROVED BY DATE MBANAKIS 2013/10/08	MOLEX MOLEX INCORPORATED
DRAFT WHERE APPLICABLE MUST REMAIN WITHIN DIMENSIONS	SEE SHEET 2	MATERIAL NO.	DOCUMENT NO. SD-76871-1150	THIS DRAWING CONTAINS INFORMATION THAT IS PROPRIETARY TO MOLEX INCORPORATED AND SHOULD NOT BE USED WITHOUT WRITTEN PERMISSION			

PART NUMBER	DESCRIPTION	DIM A
76871-1151	LIGHT PIPE UP	4.83
76871-1152	LIGHT PIPE DOWN	4.83
76871-1153	NO LIGHT PIPE	4.83
76871-1154	LIGHT PIPE UP	3.93
76871-1155	LIGHT PIPE DOWN	3.93
76871-1156	NO LIGHT PIPE	3.93
76871-1157	LIGHT PIPE UP	2.90
76871-1158	LIGHT PIPE DOWN	2.90
76871-1159	NO LIGHT PIPE	2.90



76871-1151
76871-1154
76871-1157



76871-1152
76871-1155
76871-1158



76871-1153
76871-1156
76871-1159

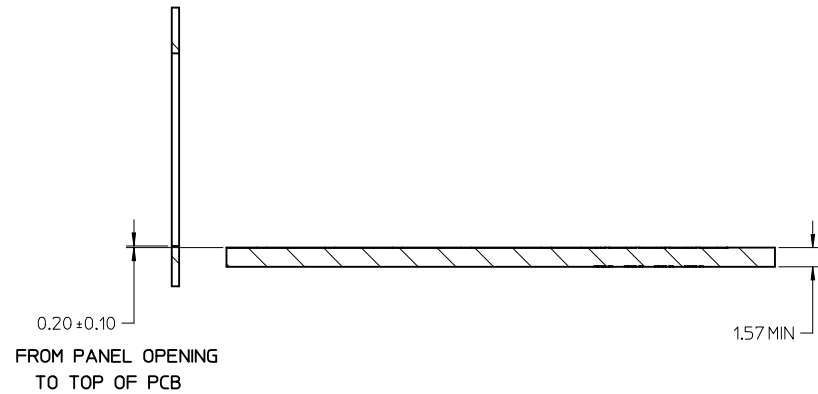
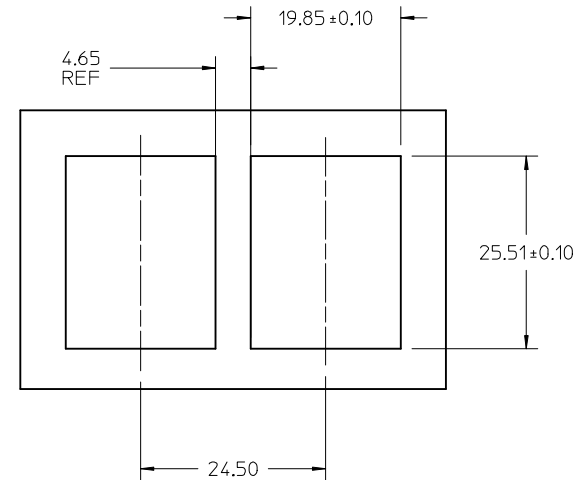

SEE SHEET 1 EC NO: UCP2014-1269 DRW: HAVERY 2013/08/02 CHKD: MBANAKIS APPR: MBANAKIS 2013/10/08	QUALITY SYMBOLS 	GENERAL TOLERANCES (UNLESS SPECIFIED)		DIMENSION STYLE MM ONLY	SCALE 2:1	DESIGN UNITS METRIC	THIRD ANGLE PROJECTION
		4 PLACES ± --- ± --- 3 PLACES ± --- ± --- 2 PLACES ± 0.13 ± --- 1 PLACE ± 0.25 ± ---	mm INCH	DRAWN BY DATE HAVERY 2013/01/31	CHECKED BY DATE	QSFP 2X1 ASSEMBLY WITH SOLDER STRAP	
DRAFT WHERE APPLICABLE MUST REMAIN WITHIN DIMENSIONS		ANGULAR ±1/2°		APPROVED BY DATE MBANAKIS 2013/10/08	MOLEX INCORPORATED		
		SEE OPTIONS		MATERIAL NO. DOCUMENT NO.		SHEET NO. 2 OF 3	
THIS DRAWING CONTAINS INFORMATION THAT IS PROPRIETARY TO MOLEX INCORPORATED AND SHOULD NOT BE USED WITHOUT WRITTEN PERMISSION							

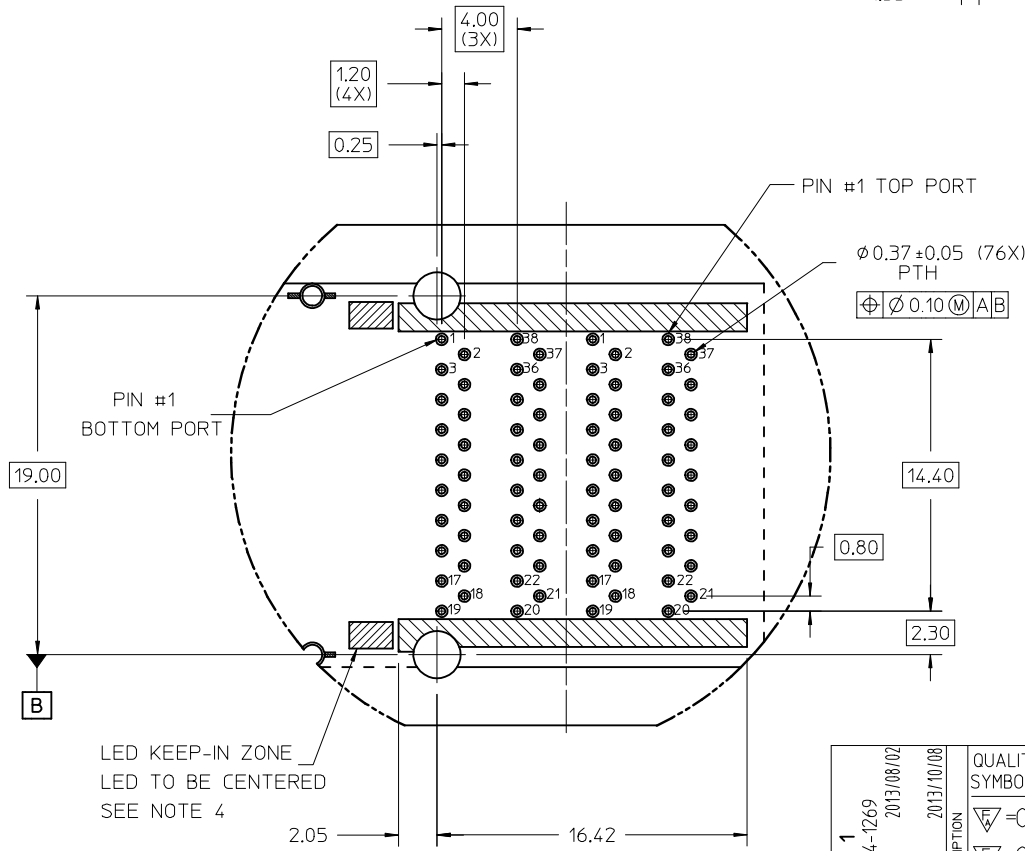
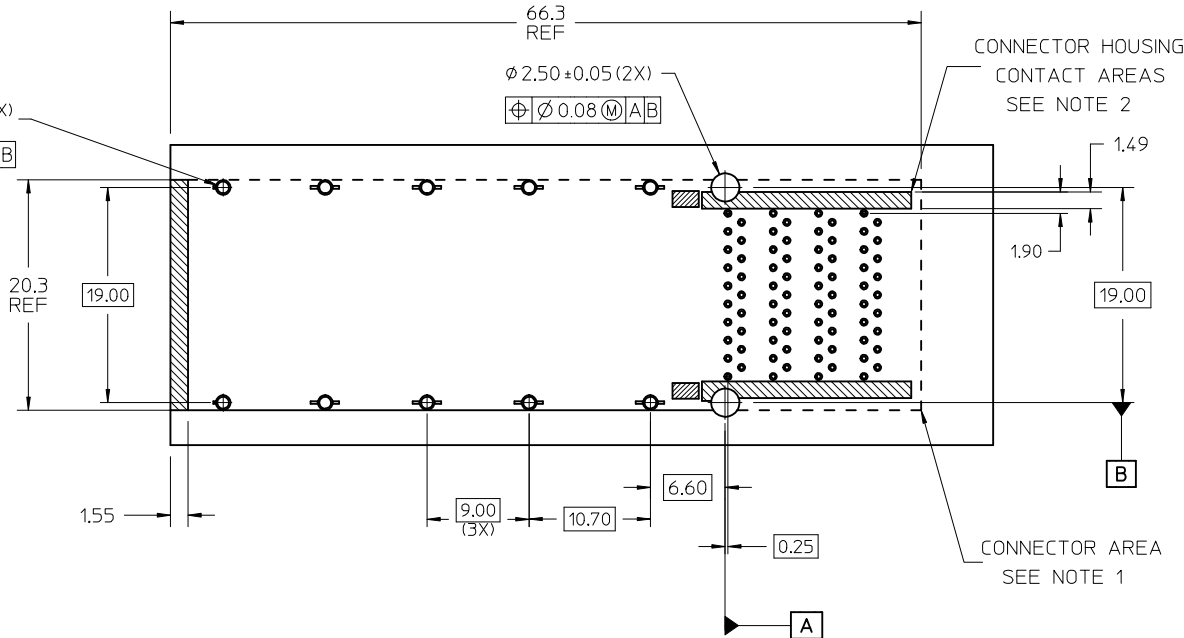
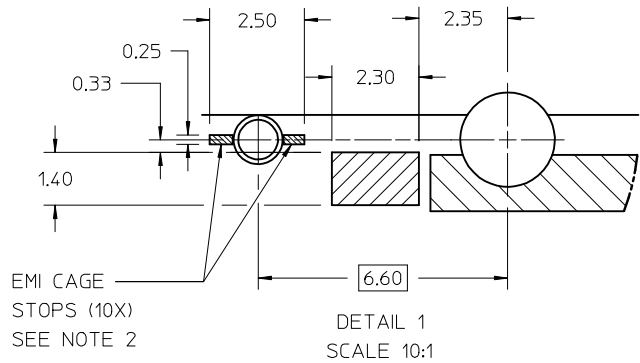

- NOTES:
1. THE ENTIRE AREA UNDER THE CONNECTOR (DASHED LINES) IS TO BE CONSIDERED A KEEP-OUT AREA FOR COMPONENTS.
 2. HATCHED AREAS REPRESENT ZONES ON THE PCB THAT COME IN CONTACT WITH OR BE IN CLOSE PROXIMITY TO THE PLASTIC HOUSING OR THE CONNECTOR CAGE. INDICATED AREAS TO BE CONSIDERED TRACE FREE.
 3. PIN NUMBERS ARE PER THE STANDARD. BOTH PORTS ARE IN THE SAME (UP-UP)MODULE ORIENTATION.
 4. LED KEEP-IN ZONE DEFINES THE PHYSICAL SPACE ALLOWED FOR PLACEMENT OF SMD CHIP STYLE LED PACKAGES INCLUDING SMD MOUNTING PADS. KEEP-IN ZONE EXTENDS VERTICALLY TO 0.8mm ABOVE THE TOP SIDE OF BOARD.
 5. SEE APPLICATION SPEC AS-76870-001 FOR RECOMMENDED DRILL HOLE SIZE.

SEE SHEET 1 EC NO: UCP2014-1269 DRWN:HAVERY 2013/08/02 CHKD: APPR:MBANAKIS 2013/10/08	QUALITY SYMBOLS	GENERAL TOLERANCES (UNLESS SPECIFIED)	DIMENSION STYLE MM ONLY	SCALE 3:1	DESIGN UNITS METRIC	THIRD ANGLE PROJECTION																				
	$\nabla = 0$ $\nabla = 0$ $\nabla = 0$	<table border="1"> <tr><th>mm</th><th>INCH</th></tr> <tr><td>4 PLACES ± ---</td><td>± ---</td></tr> <tr><td>3 PLACES ± ---</td><td>± ---</td></tr> <tr><td>2 PLACES ± 0.13</td><td>± ---</td></tr> <tr><td>1 PLACE ± 0.25</td><td>± ---</td></tr> </table>	mm	INCH	4 PLACES ± ---	± ---	3 PLACES ± ---	± ---	2 PLACES ± 0.13	± ---	1 PLACE ± 0.25	± ---	<table border="1"> <tr><th>mm</th><th>INCH</th></tr> <tr><td>4 PLACES ± ---</td><td>± ---</td></tr> <tr><td>3 PLACES ± ---</td><td>± ---</td></tr> <tr><td>2 PLACES ± 0.13</td><td>± ---</td></tr> <tr><td>1 PLACE ± 0.25</td><td>± ---</td></tr> </table>	mm	INCH	4 PLACES ± ---	± ---	3 PLACES ± ---	± ---	2 PLACES ± 0.13	± ---	1 PLACE ± 0.25	± ---	DRAWN BY HAVERY DATE 2013/01/31 CHECKED BY DATE	TITLE QSFP 2X1 ASSEMBLY WITH SOLDER STRAP	
mm	INCH																									
4 PLACES ± ---	± ---																									
3 PLACES ± ---	± ---																									
2 PLACES ± 0.13	± ---																									
1 PLACE ± 0.25	± ---																									
mm	INCH																									
4 PLACES ± ---	± ---																									
3 PLACES ± ---	± ---																									
2 PLACES ± 0.13	± ---																									
1 PLACE ± 0.25	± ---																									
		ANGULAR ± 1/2°	APPROVED BY MBANAKIS DATE 2013/10/08	MOLEX INCORPORATED DOCUMENT NO. SD-76871-1150 SHEET NO. 3 OF 3																						
		DRAFT WHERE APPLICABLE MUST REMAIN WITHIN DIMENSIONS	SEE SHEET 2 THIS DRAWING CONTAINS INFORMATION THAT IS PROPRIETARY TO MOLEX INCORPORATED AND SHOULD NOT BE USED WITHOUT WRITTEN PERMISSION																							