

FT

- Terminal Pins : Kinked
- Actuator Color : Yellow

Washable

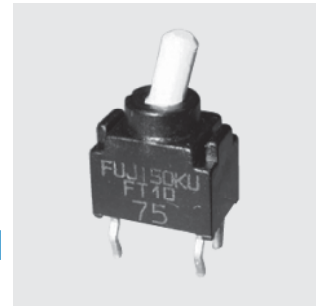

Ultra-Miniature Toggle Switch

RoHS Compliant

■ Features

1. Ultra-miniature toggle switch for high density mounting.
2. Washable.
3. Terminal pin pitch : 2.54 mm.
4. Independent detent mechanism ensures light operational feel.
5. Clip contact mechanism for long-term contact reliability.
6. Gold-plated contacts.

■ Specifications

Rating	Max.	28VDC 0.4VA max.
	Min.	1μ A 20mVDC
Initial contact resistance	100mΩ max.	(1.5mA 200μ VAC)
Dielectric strength	250VAC 1 minute	
Insulation resistance	500MΩ min.	(250VDC)
Electrical life	10,000 cycles at max. rating	
	50,000 cycles at min. rating (D,E type)	
	30,000 cycles at min. rating (F,G type)	
Operating temperature range	-40°C~+85°C	
Storage temperature range	-40°C~+85°C	

■ Part Numbering

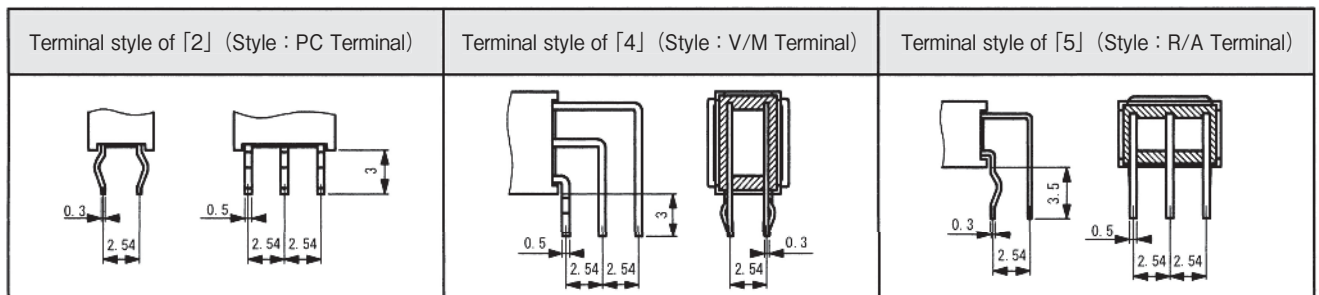
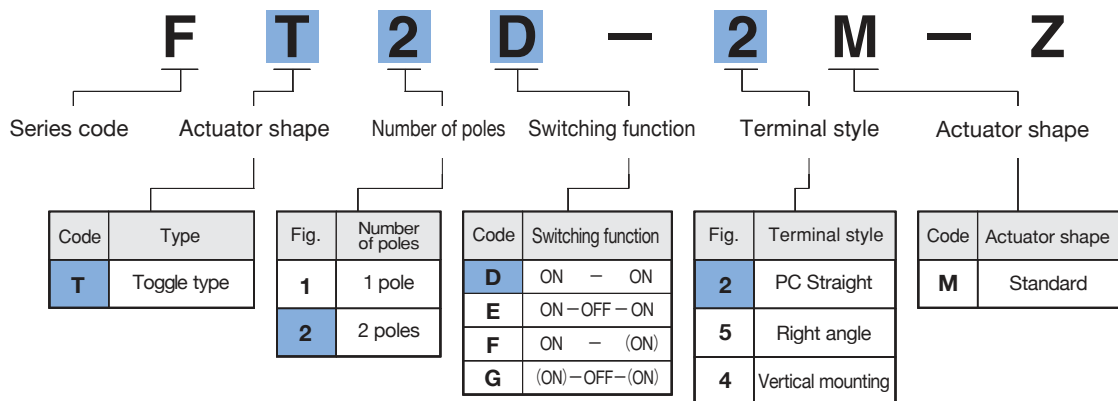

(ON) : Momentary.

FT

SPDT

PC Straight

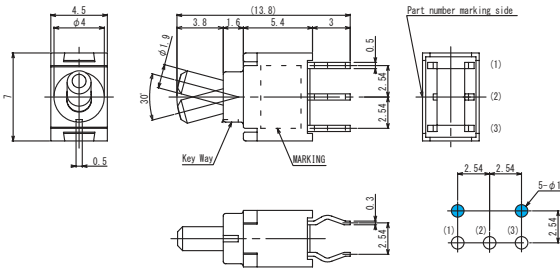

Terminal numbers are not shown on the switch.

(Topview)
PC hole Layouts

Switching function			
Part No.			
FT1D-2M-Z	ON	—	ON
☆ FT1E-2M-Z	ON	OFF	ON
☆ FT1F-2M-Z	ON	—	(ON)
★ FT1G-2M-Z	(ON)	OFF	(ON)
Connecting terminals	2-3	—	2-1

DPDT

PC Straight

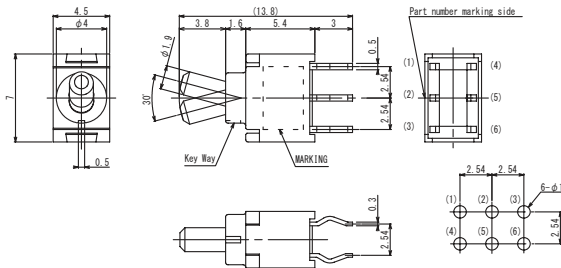

Terminal numbers are not shown on the switch.

(Topview)
PC hole Layouts

Switching function			
Part No.			
FT2D-2M-Z	ON	—	ON
☆ FT2E-2M-Z	ON	OFF	ON
★ FT2F-2M-Z	ON	—	(ON)
★ FT2G-2M-Z	(ON)	OFF	(ON)
Connecting terminals	2-3 5-6	—	2-1 5-4

SPDT

Right Angle Terminal

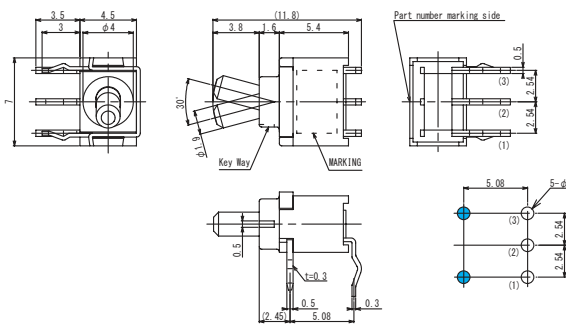
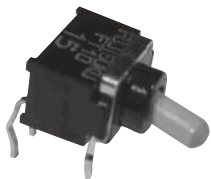

Terminal numbers are not shown on the switch.

(Topview)
PC hole Layouts

Switching function			
Part No.			
FT1D-5M-Z	ON	—	ON
FT1E-5M-Z	ON	OFF	ON
Connecting terminals	2-1	—	2-3

DPDT

Right Angle Terminal

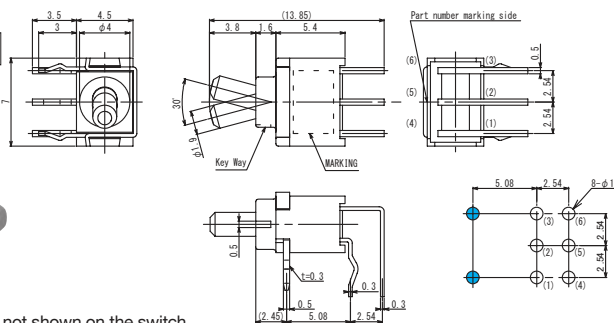
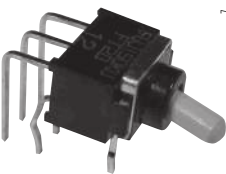

Terminal numbers are not shown on the switch.

(Topview)
PC hole Layouts

Switching function			
Part No.			
☆ FT2D-5M-Z	ON	—	ON
★ FT2E-5M-Z	ON	OFF	ON
Connecting terminals	2-1 5-4	—	2-3 5-6

(ON) : Momentary.

☆ : Semi-standard products. ★ : Made to order products.

SPDT

Vertical mounting terminal

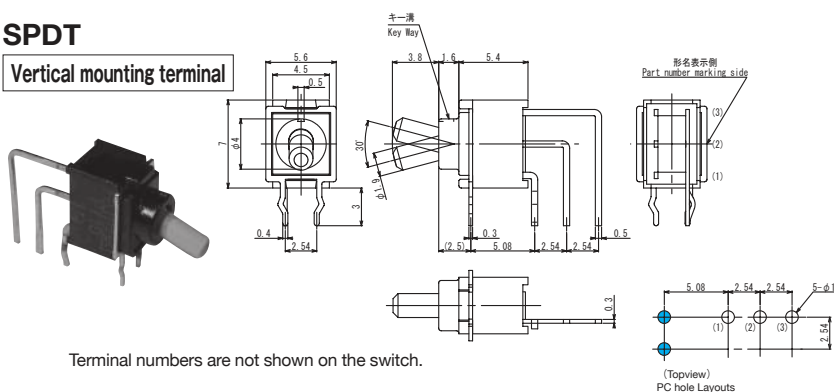

Terminal numbers are not shown on the switch.

Switching function			
Part No.			
☆FT1D-4M-Z	ON	—	ON
★FT1E-4M-Z	ON	OFF	ON
Connecting terminals	2—3	—	2—1

DPDT

Vertical mounting terminal

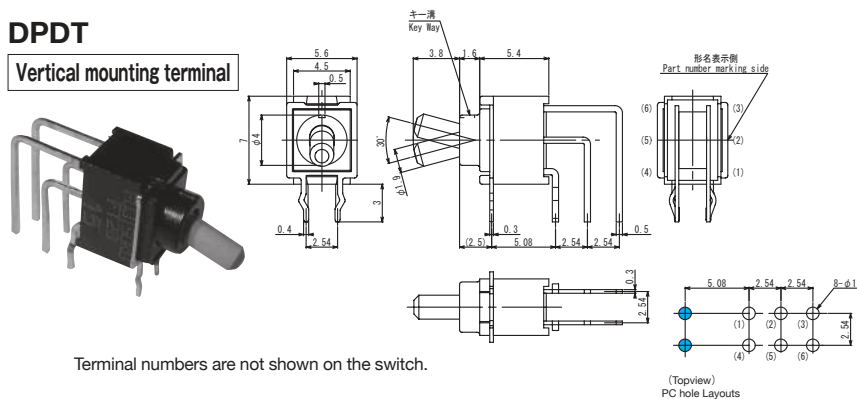

Terminal numbers are not shown on the switch.

Switching function			
Part No.			
FT2D-4M-Z	ON	—	ON
★FT2E-4M-Z	ON	OFF	ON
Connecting terminals	2—3 5—6	—	2—1 5—4

Soldering Specifications

(1) Manual Soldering

Device : Soldering iron
380°C, Max.; 3 seconds, Max.

(2) Auto Soldering

Device : Jet wave type or dip type
275°C, Max.; 6 seconds, Max.

- Pre-heating should be done at temperatures from 80 to 120°C and within 120 sec.

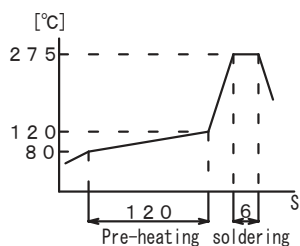

- (3) When soldering two or more terminals to a common land, use solder resist to separate them.

Flux Cleaning

- (1) Solvent : Fluorine or Alcohol type.
- (2) Cleaning after soldering should be done after the PC board is exposed to room temperature (30°C or below) for 1 to 2 hours.
- (3) Do not use ultrasonic cleaning.

Packaging Specifications

