

# ARF461C(G) ARF461D(G)

## RF POWER MOSFETs N-CHANNEL ENHANCEMENT MODE

250V 150W 65MHz

The ARF461C and ARF461D comprise a symmetric pair of common drain RF power transistors designed for push-pull scientific, commercial, medical and industrial RF power amplifier applications up to 65 MHz. They have been optimized for both linear and high efficiency classes of operation.

- Specified 250 Volt, 40.68 MHz Characteristics:
  - Output Power = 150 Watts.
  - Gain = 13dB (Class AB)
  - Efficiency = 75% (Class C)
- Low Cost Common Source RF Package.
- Low  $V_{th}$  thermal coefficient.
- Low Thermal Resistance.
- Optimized SOA for Superior Ruggedness.
- RoHS Compliant 

### MAXIMUM RATINGS

All Ratings:  $T_C = 25^\circ\text{C}$  unless otherwise specified.

Symbol	Parameter	ARF461CG/DG	Unit
$V_{DSS}$	Drain-Source Voltage	1000	V
$V_{DGO}$	Drain-Gate Voltage	1000	
$I_D$	Continuous Drain Current @ $T_C = 25^\circ\text{C}$	6.5	A
$V_{GS}$	Gate-Source Voltage	$\pm 30$	V
$P_D$	Total Power Dissipation @ $T_C = 25^\circ\text{C}$	250	W
$R_{\theta JC}$	Junction to Case	0.50	$^\circ\text{C}/\text{W}$
$T_J, T_{STG}$	Operating and Storage Junction Temperature Range	-55 to 150	$^\circ\text{C}$
$T_L$	Lead Temperature: 0.063" from Case for 10 Sec.	300	

### STATIC ELECTRICAL CHARACTERISTICS

Symbol	Parameter	Min	Typ	Max	Unit
$BV_{DSS}$	Drain-Source Breakdown Voltage ( $V_{GS} = 0\text{V}, I_D = 250 \mu\text{A}$ )	1000			V
$V_{DS(ON)}$	On State Drain Voltage <sup>1</sup> ( $I_{D(ON)} = 3.25\text{A}, V_{GS} = 10\text{V}$ )			6.5	
$I_{DSS}$	Zero Gate Voltage Drain Current ( $V_{DS} = V_{DSS}, V_{GS} = 0\text{V}$ )			25	$\mu\text{A}$
	Zero Gate Voltage Drain Current ( $V_{DS} = 0.8V_{DSS}, V_{GS} = 0, T_C = 125^\circ\text{C}$ )			250	
$I_{GSS}$	Gate-Source Leakage Current ( $V_{DS} = \pm 30\text{V}, V_{GS} = 0\text{V}$ )			$\pm 100$	nA
$g_{fs}$	Forward Transconductance ( $V_{DS} = 25\text{V}, I_D = 3.25\text{A}$ )	3	4		mhos
$V_{GS(TH)}$	Gate Threshold Voltage ( $V_{DS} = V_{GS}, I_D = 50\text{mA}$ )	3		5	Volts



**CAUTION:** These Devices are Sensitive to Electrostatic Discharge. Proper Handling Procedures Should Be Followed.

## Dynamic Characteristics

ARF461C/D

Symbol	Parameter	Test Conditions	Min	Typ	Max	Unit
$C_{iss}$	Input Capacitance	$V_{GS} = 0V$ $V_{DS} = 50V$ $f = 1MHz$		1700		pF
$C_{oss}$	Output Capacitance			175		
$C_{rss}$	Reverse Transfer Capacitance			50		
$t_{d(on)}$	Turn-On Delay Time	$V_{GS} = 15V$ $V_{DD} = 0.5V_{DSS}$ $I_D = I_{D(Cont.)} @ 25^\circ C$ $R_G = 1.6\Omega$		8		ns
$t_r$	Rise Time			5		
$t_{d(off)}$	Turn-off Delay Time			21		
$t_f$	Fall Time			10.1		

## Functional Characteristics

Symbol	Characteristic	Test Conditions	Min	Typ	Max	Unit
$G_{PS}$	Common Source Amplifier Power Gain	$f = 40.68MHz$ $V_{GS} = 0V$ $V_{DD} = 250V$ $P_{OUT} = 150W$	13	15		dB
$\eta$	Drain Efficiency		70	75		%
$\Psi$	Electrical Ruggedness VSWR 10:1		No Degradation in Output Power			

① Pulse Test: Pulse width < 380  $\mu S$ , Duty Cycle < 2%

APT Reserves the right to change, without notice, the specifications and information contained herein.

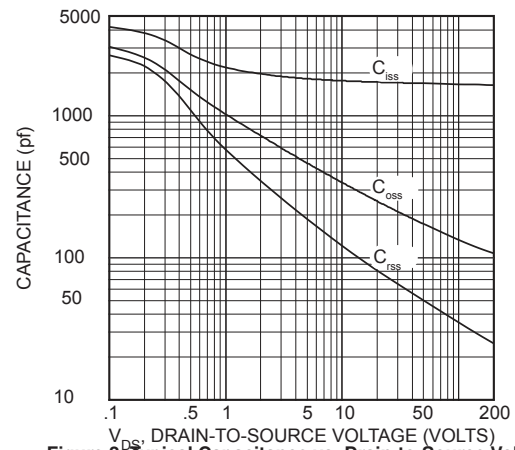

Figure 2, Typical Capacitance vs. Drain-to-Source Voltage

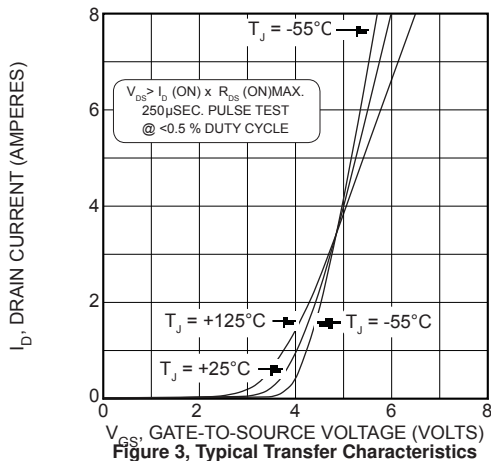

Figure 3, Typical Transfer Characteristics

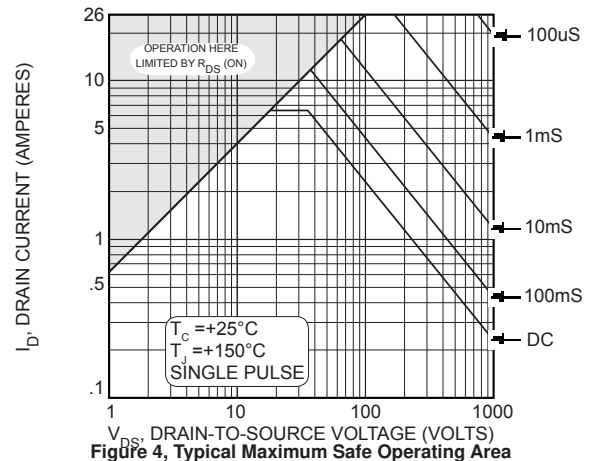

Figure 4, Typical Maximum Safe Operating Area

**ARF461C/D**

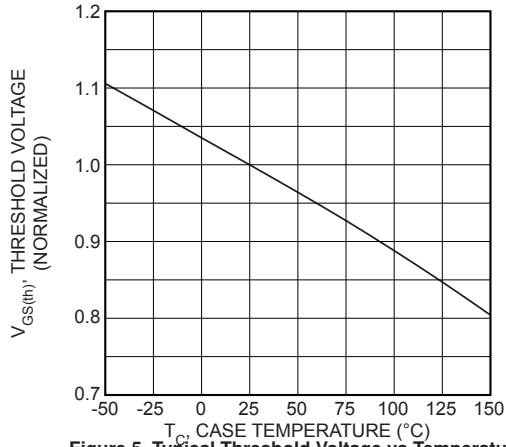

Figure 5, Typical Threshold Voltage vs Temperature

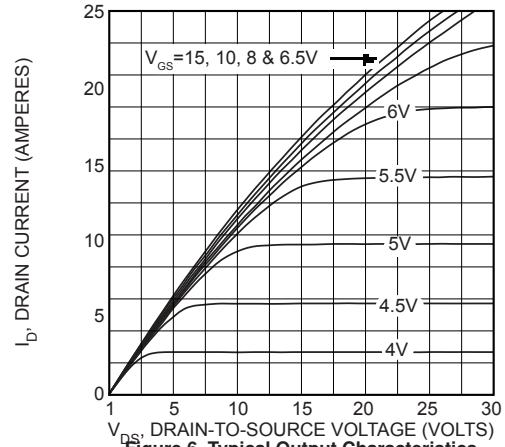

Figure 6, Typical Output Characteristics

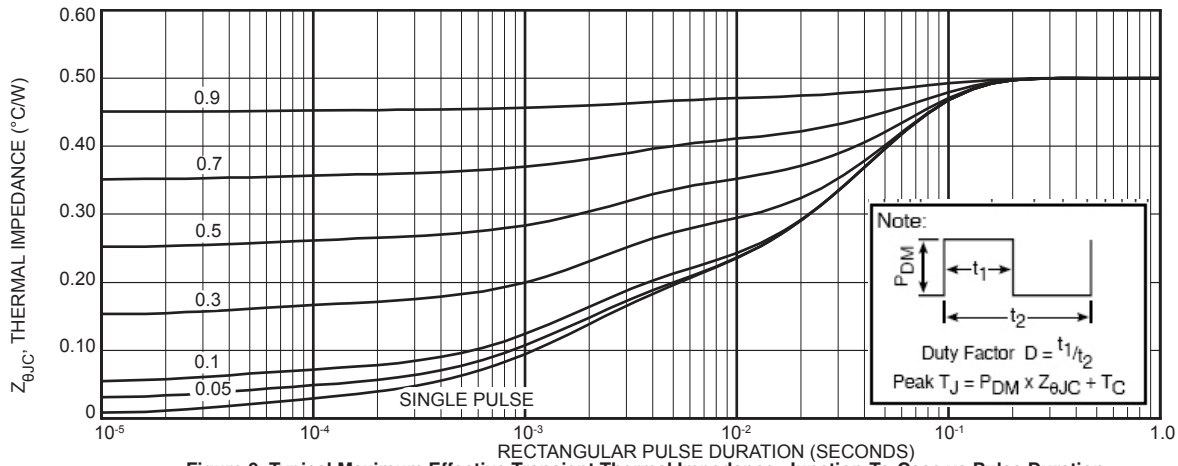

Figure 9, Typical Maximum Effective Transient Thermal Impedance, Junction-To-Case vs Pulse Duration

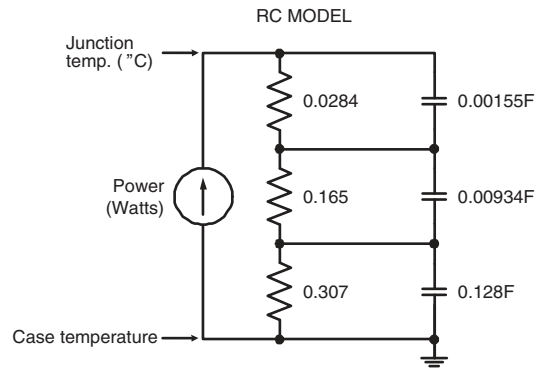

Figure 9a, TRANSIENT THERMAL IMPEDANCE MODEL

Table 1 - Typical Class AB Large Signal Input - Output Impedance

Freq. (MHz)	Z <sub>in</sub> (Ω)	Z <sub>OL</sub> (Ω)
2.0	20.9 - j 9.2	38 - j 2.6
13.5	2.4 - j 6.8	31 - j 14
27	.57 - j 2.6	19.6 - j 17.6
40	.31 - j 0.5	12.5 - j 15.8
65	.44 + j 1.9	6.0 - j 10.5

Z<sub>in</sub> - Gate shunted with 25Ω

I<sub>DQ</sub> = 100mA

Z<sub>OL</sub> - Conjugate of optimum load for 150 Watts output at V<sub>DD</sub> = 125V

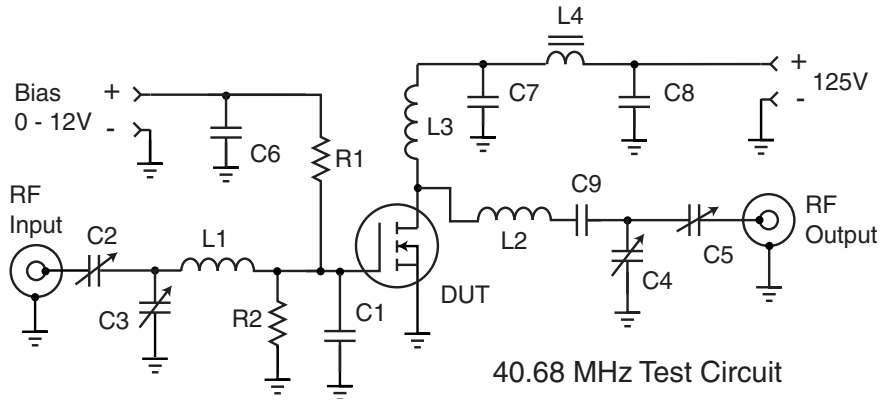

- C1 -- 2000 pF 100V NPO chip mounted at gate lead
- C2-C5 -- Arco 463 Mica trimmer
- C6-C8 -- .1µF 500V ceramic chip
- C9 -- 2200 pF 500V chip
- L1 -- 4t #20 AWG .25"ID .3"L ~80nH
- L2 -- 6t #16 AWG .312" ID .4"L ~185
- L3 -- 15t #24 AWG .25"ID ~.85uH
- L4 -- VK200-4B ferrite choke 3uH
- R1-R2 -- 51 Ohm 0.5W Carbon
- DUT = ARF461C/D

**TO-247 Package Outline**

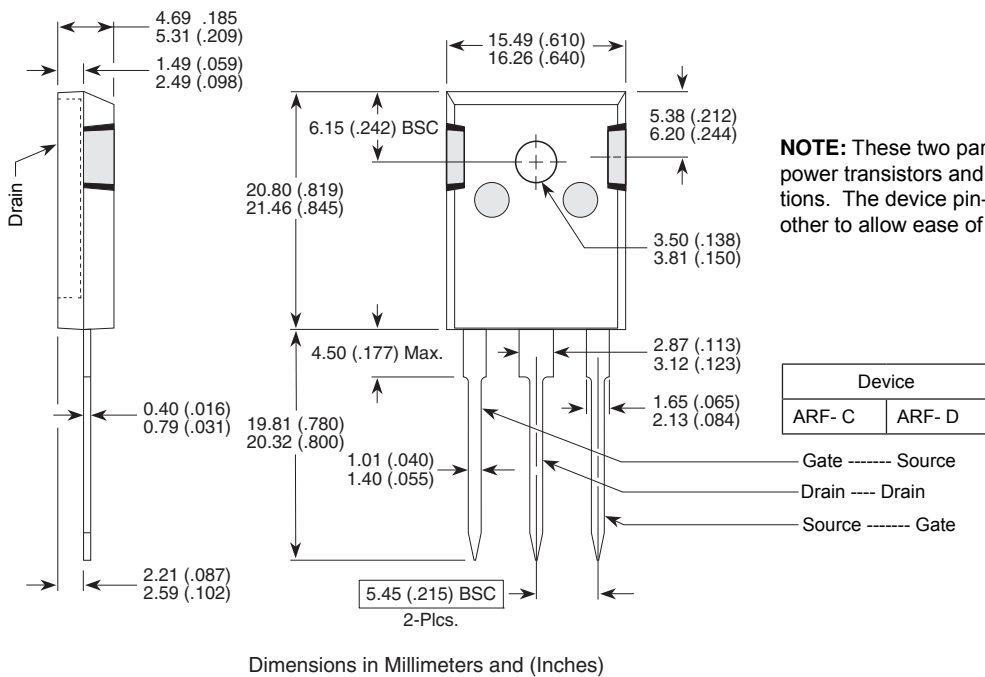

**NOTE:** These two parts comprise a symmetric pair of RF power transistors and meet the same electrical specifications. The device pin-outs are the mirror image of each other to allow ease of use as a push-pull pair.