

Description

The AP3417C is a high efficiency step-down DC-DC voltage converter. The chip operation is optimized by peak-current mode architecture with built-in synchronous power MOSFET switchers. The oscillator and timing capacitors are all built-in providing an internal switching frequency of 1.5MHz that allows the use of small surface mount inductors and capacitors for portable product implementations.

Integrated Soft Start (SS), Under Voltage Lock Out (UVLO), Thermal Shutdown Detection (TSD) and Short Circuit Protection are designed to provide reliable product applications.

The device is available in adjustable output voltage version ranging from 0.6V to $0.9 \times V_{IN}$ when input voltage range is from 2.5V to 5.5V, and is able to deliver up to 1A.

The AP3417C is available in SOT-23-5 and W-DFN2020-6 (Type US) packages.

Features

- High Efficiency Buck Power Converter
- Wide Input Voltage Range: 2.5V to 5.5V
- Adjustable Output Voltage: 0.6V to $0.9 \times V_{IN}$
- Low $R_{DS(ON)}$ Internal Switches: $200m\Omega$ ($V_{IN} = 5V$)
- Built-In Power Switches for Synchronous Rectification with High Efficiency
- Output Current: 1.0A
- Feedback Voltage: 600mV
- 1.5MHz Constant Frequency Operation
- Thermal Shutdown Protection
- Low Dropout Operation at 100% Duty Cycle
- No Schottky Diode Required
- Input Over Voltage Protection
- Output Over Voltage Protection
- Over Current Protection
- **Totally Lead-Free & Fully RoHS Compliant (Notes 1 & 2)**
- **Halogen and Antimony Free. "Green" Device (Note 3)**

- Notes:
1. No purposely added lead. Fully EU Directive 2002/95/EC (RoHS), 2011/65/EU (RoHS 2) & 2015/863/EU (RoHS 3) compliant.
 2. See <https://www.diodes.com/quality/lead-free/> for more information about Diodes Incorporated's definitions of Halogen- and Antimony-free, "Green" and Lead-free.
 3. Halogen- and Antimony-free "Green" products are defined as those which contain <900ppm bromine, <900ppm chlorine (<1500ppm total Br + Cl) and <1000ppm antimony compounds.

Pin Assignments

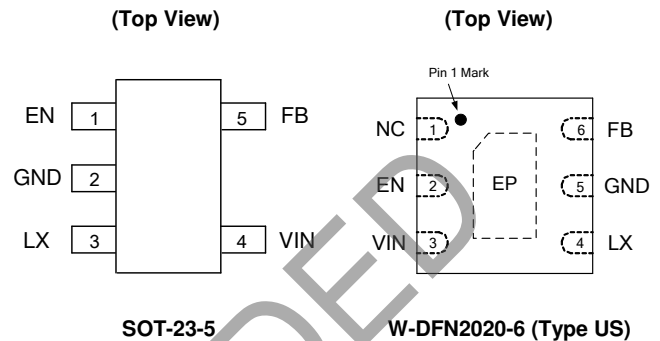

Applications

- Post DC-DC Voltage Regulation
- PDA and Notebook Computer

Typical Applications Circuit

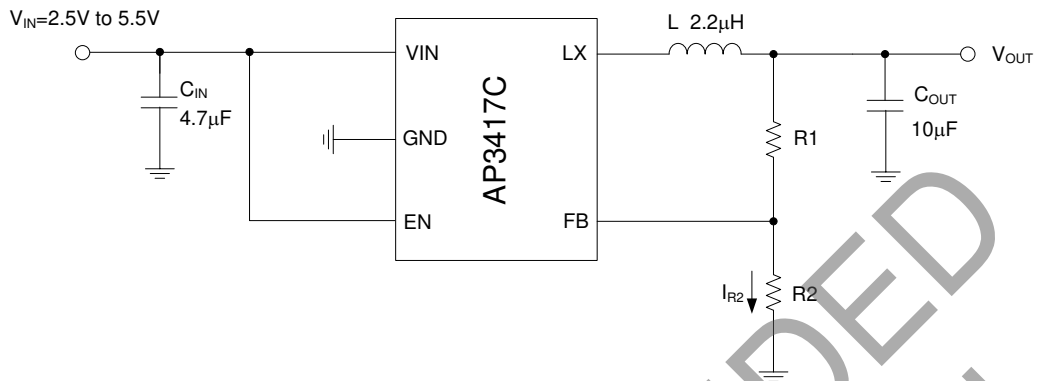

Component Guide

V _{OUT} (V)	R1 (kΩ)	R2 (kΩ)	L (µH)
3.3	450	100	2.2
2.5	320	100	2.2
1.8	200	100	2.2
1.2	100	100	2.2
1.0	66	100	2.2

Pin Descriptions

Pin Number		Pin Name	Function
SOT-23-5	W-DFN2020-6 (Type US)		
1	2	EN	Chip enable pin. Active high
2	5	GND	Ground pin
3	4	LX	Switch output pin
4	3	VIN	Power supply
5	6	FB	Feedback voltage of output
—	1	NC	No internal connection

Functional Block Diagram

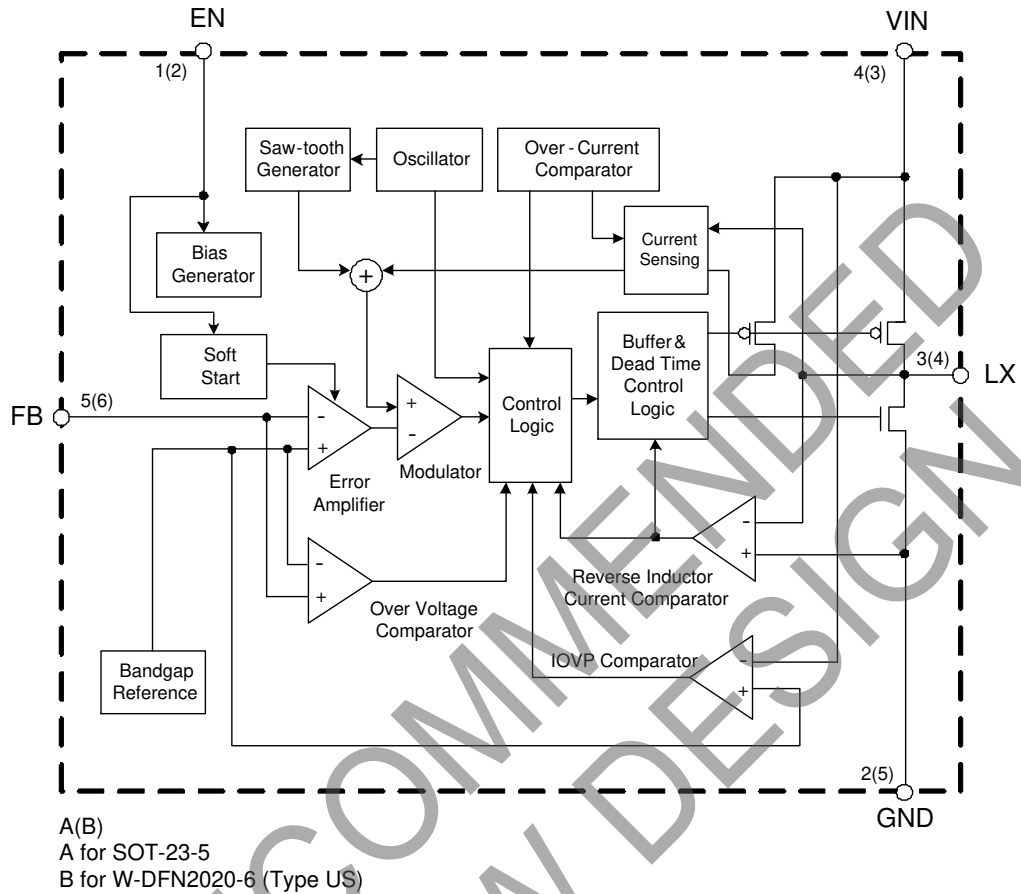

Absolute Maximum Ratings (Note 4)

Symbol	Parameter	Rating		Unit
V_{IN}	Input Voltage for the MOSFET Switch	0 to 6.0		V
V_{EN}	Enable Input Voltage	-0.3 to $V_{IN} + 0.3$		V
I_{LX}	LX Pin Switch Current	1.8		A
P_D	Power Dissipation (On PCB, $T_A = +25^\circ\text{C}$)	SOT-23-5	0.4	W
		W-DFN2020-6 (Type US)	1.89	
θ_{JA}	Thermal Resistance (Junction to Ambient, Simulation)	SOT-23-5	250	$^\circ\text{C/W}$
		W-DFN2020-6 (Type US)	53	
θ_{JC}	Thermal Resistance (Junction to Case, Simulation)	SOT-23-5	130	$^\circ\text{C/W}$
		W-DFN2020-6 (Type US)	25	
T_J	Operating Junction Temperature	+155		$^\circ\text{C}$
T_{STG}	Storage Temperature	-55 to +150		$^\circ\text{C}$
T_{OP}	Operating Temperature	-40 to +85		$^\circ\text{C}$
V_{MM}	ESD (Machine Model)	200		V
V_{HBM}	ESD (Human Body Model)	2000		V

Note 4: Stresses greater than those listed under "Absolute Maximum Ratings" can cause permanent damage to the device. These are stress ratings only, and functional operation of the device at these or any other conditions beyond those indicated under "Recommended Operating Conditions" is not implied. Exposure to "Absolute Maximum Ratings" for extended periods can affect device reliability.

Recommended Operating Conditions

Symbol	Parameter	Min	Max	Unit
V _{IN}	Supply Input Voltage	2.5	5.5	V
T _A	Operating Ambient Temperature	-40	+85	°C
T _J	Operating Junction Temperature	-40	+125	°C

Electrical Characteristics (@V_{IN} = V_{EN} = 5V, V_{OUT} = 1.2V, V_{FB} = 0.6V, L = 2.2μH, C_{IN} = 4.7μF, C_{OUT} = 10μF, T_A = +25°C, unless otherwise specified.)

Symbol	Parameters	Conditions	Min	Typ	Max	Unit
V _{IN}	Input Voltage Range	—	2.5	—	5.5	V
I _{OFF}	Shutdown Current	V _{EN} = 0	—	—	0.1	μA
I _{ON}	Active Current	V _{FB} = 0.55V	—	220	—	μA
V _{FB}	Regulated Feedback Voltage	—	0.588	0.6	0.612	V
ΔV _{OUT} /V _{OUT}	Regulated Output Voltage Accuracy	V _{IN} = 2.5V to 5.5V, I _{OUT} = 0 to 1.0A	-3	—	3	%
I _{PK}	Peak Inductor Current	—	1.5	1.9	—	A
f _{OSC}	Oscillator Frequency	V _{IN} = 2.5V to 5.5V	1.2	1.5	1.8	MHz
R _{DS(ON)P}	PMOSFET R _{DS(ON)}	V _{IN} = 5V	—	200	—	mΩ
R _{DS(ON)N}	NMOSFET R _{DS(ON)}	V _{IN} = 5V	—	200	—	mΩ
V _{EN_H}	EN High Level Input Voltage	—	1.5	—	—	V
V _{EN_L}	EN Low Level Input Voltage	—	—	—	0.4	V
I _{EN}	EN Input Current	—	—	—	0.1	μA
t _{SS}	Soft Start Time	—	—	400	—	μs
D _{MAX}	Maximum Duty Cycle	—	100	—	—	%
V _{UVLO}	Under Voltage Lock Out Threshold	Rising	—	2.3	—	V
		Falling	—	2.1	—	
		Hysteresis	—	0.2	—	
T _{SD}	Thermal Shutdown	Hysteresis = +30°C	—	+155	+160	°C

NOT RECOMMENDED FOR NEW DESIGN

Performance Characteristics (@ $V_{IN} = 5V$, $T_A = +25^\circ C$, unless otherwise specified.)

Efficiency vs. Output Current

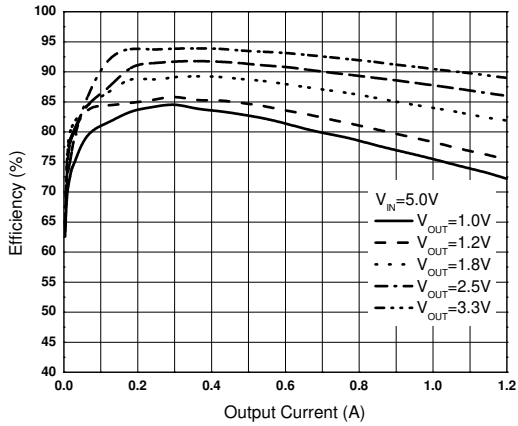

Regulated Feedback Voltage vs. Temperature

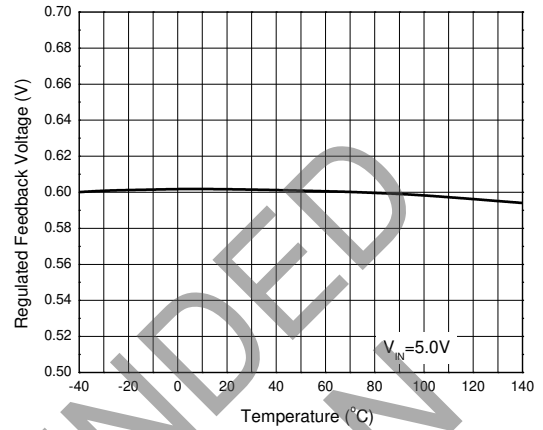

Output Ripple ($I_{OUT}=0A$)

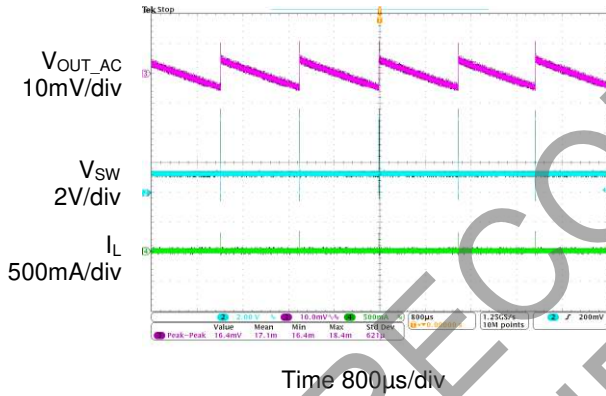

Output Ripple ($I_{OUT}=1A$)

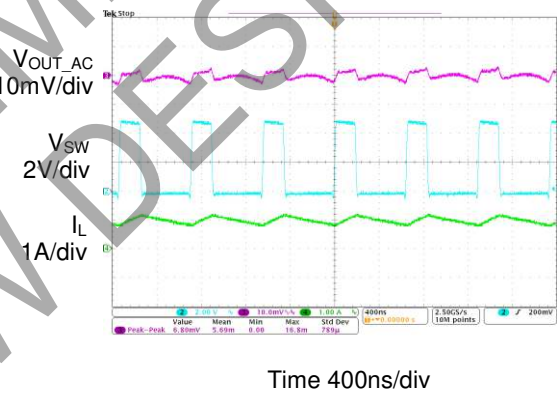

Enable Turn On ($I_{OUT}=1A$)

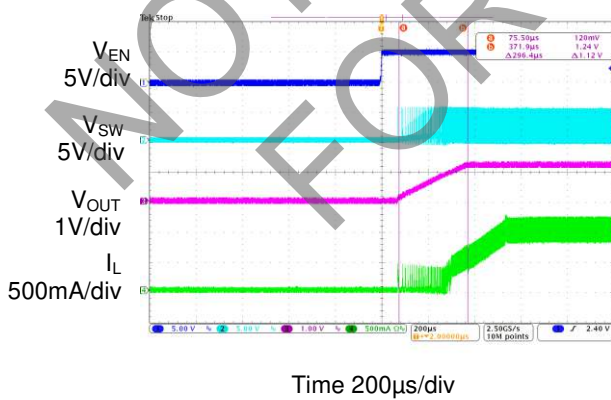

Enable Turn Off ($I_{OUT}=1A$)

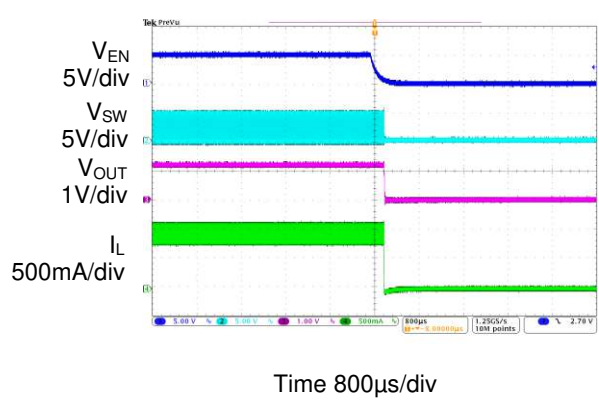

Performance Characteristics (continued) (@ $V_{IN} = 5V$, $T_A = +25^\circ C$, unless otherwise specified.)

Short Circuit Protection ($I_{OUT}=1A$)

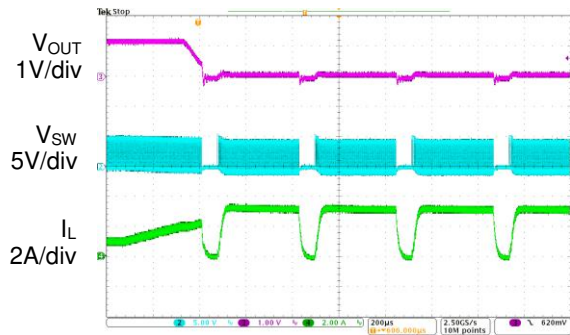

Short Circuit Protection Recovery ($I_{OUT}=1A$)

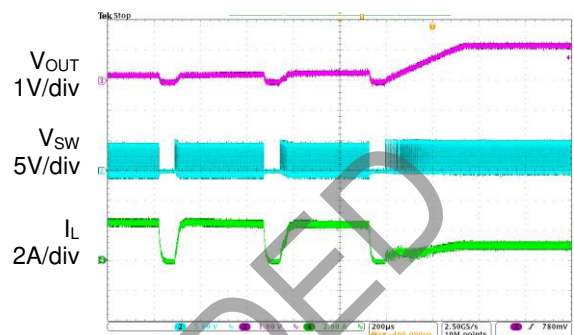

NOT RECOMMENDED FOR NEW DESIGN

Application Information

Typical application circuit is shown in the *Typical Applications Circuit* and for the circuit parameters setting please refers to the following descriptions.

Under Voltage Lockout (UVLO) Circuit

When the V_{IN} drops lower than the UVLO detector threshold, the UVLO circuit starts to operate, V_{REF} stops, and high-side switch and low-side switch built-in switch transistors turn “OFF”. As a result, V_{OUT} drops according to the C_{OUT} capacitance value and the load. When the V_{IN} is rising higher than UVLO released voltage, the IC will restart the operation.

Short Circuit Protection and Recovery

When the AP3417C output node is shorted to GND that V_{FB} drops under 0.42V, AP3417C will enter hiccup mode to protect itself. If short circuit is removed, and V_{FB} rises over 0.42V, the AP3417C recovers to normal operation again. If the AP3417C reaches OCP threshold while short circuit, the AP3417C will enters cycle by cycle current limit mode until the current under OCP threshold.

Over Temperature Protection

The internal thermal temperature protection circuitry is provided to protect the integrated circuit in the event that the maximum junction temperature is exceeded. When the junction temperature exceeds +160°C, it shuts down the internal control circuit and switching power MOSFET. The AP3417C will restart automatically under the control of soft start circuit when the junction temperature decreases to +145°C.

Setting the Output Voltage

The output voltage can be adjusted from 0.6V to $0.9 \cdot V_{IN}$ using an external resistor divider. Table 1 shows a list of resistor selections for common output voltages. Resistor R1 is selected based on a design tradeoff between efficiency and output voltage accuracy. For high values of R1 there is less current consumption in the feedback network. However the tradeoff is output voltage accuracy due to the bias current in the error amplifier. Meanwhile, the input capacitor should close to IC for preventing unexpected influences.

V_{OUT} (V)	R1 (kΩ)	R2 (kΩ)	L (μH)
3.3	450	100	2.2
2.5	320	100	2.2
1.8	200	100	2.2
1.2	100	100	2.2
1.0	66	100	2.2

Table1. Resistor Selection for Common Output

Enable Control Input

Force this pin voltage above 1.5V enables the chip, and below 0.4V shuts down the device. When using this function to control input, please note the following information. Pay attention to input voltage, if input voltage is less than 5.2V, all functions work well without other concerns. If input voltage is higher than 5.2V, please confirm that EN pin must be connected to V_{IN} directly without the capacitor from EN to GND.

Ordering Information

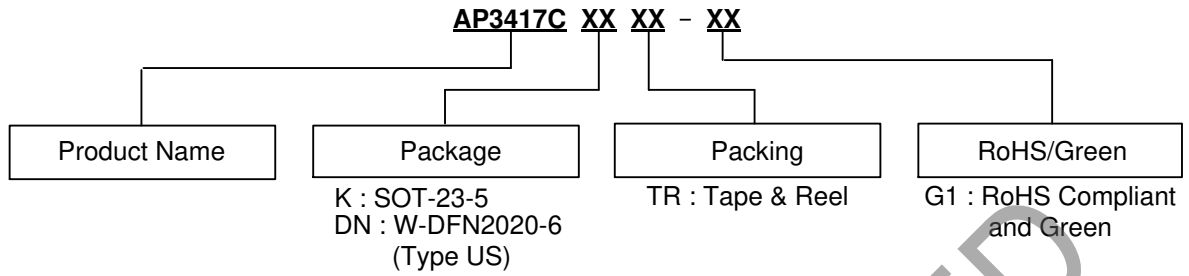

Package	Temperature Range	Part Number	Marking ID	Packing
SOT-23-5	-40 to +85°C	AP3417CKTR-G1	G4I	3000 / Tape & Reel
W-DFN2020-6 (Type US)	-40 to +85°C	AP3417CDNTR-G1	BH	3000 / Tape & Reel

Marking Information

(1) SOT-23-5

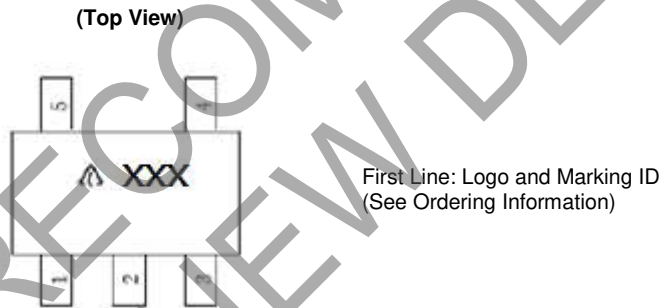

(2) W-DFN2020-6 (Type US)

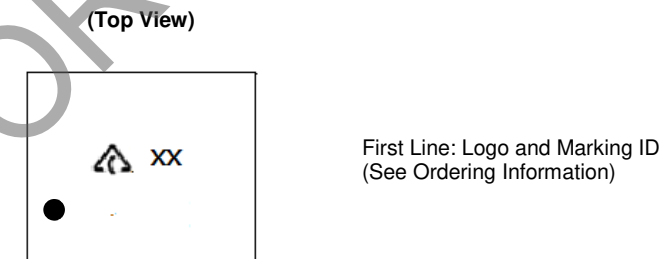

Package Outline Dimensions (All dimensions in mm(inch).)

(1) Package Type: SOT-23-5

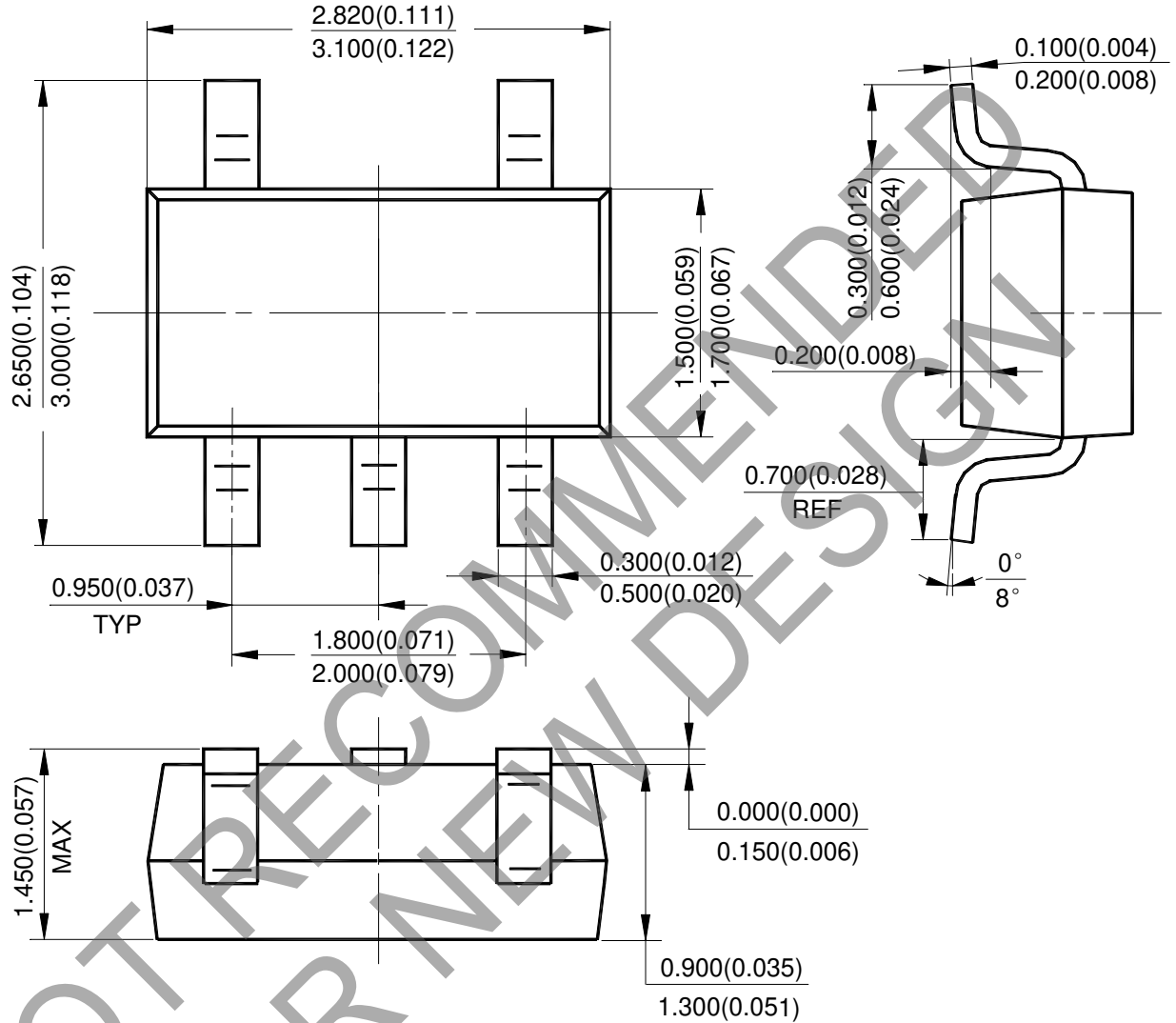

Package Outline Dimensions (continued)

Please see <http://www.diodes.com/package-outlines.html> for the latest version.

(2) Package Type: W-DFN2020-6 (Type US)

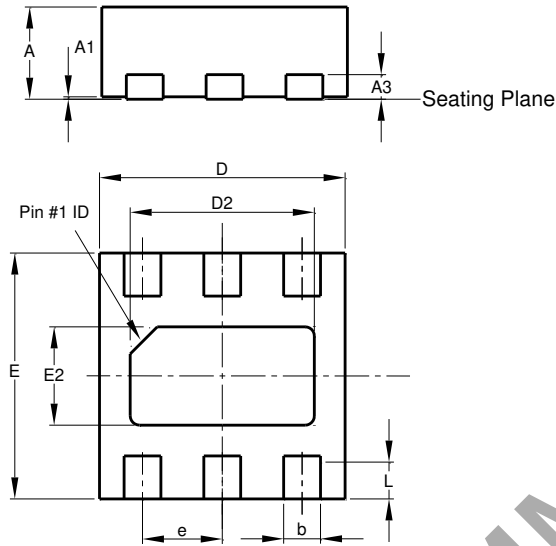

W-DFN2020-6 (Type US)			
Dim	Min	Max	Typ
A	0.70	0.80	0.75
A1	0.00	0.05	--
A3	0.20 REF		
b	0.25	0.35	0.30
D	1.95	2.075	2.00
D2	1.35	1.60	1.50
E	1.95	2.075	2.00
E2	0.65	0.90	0.80
e	0.65 BSC		
L	0.25	0.45	0.35
All Dimensions in mm			

NOT RECOMMENDED FOR NEW DESIGN

Suggested Pad Layout

(1) Package Type: SOT-23-5

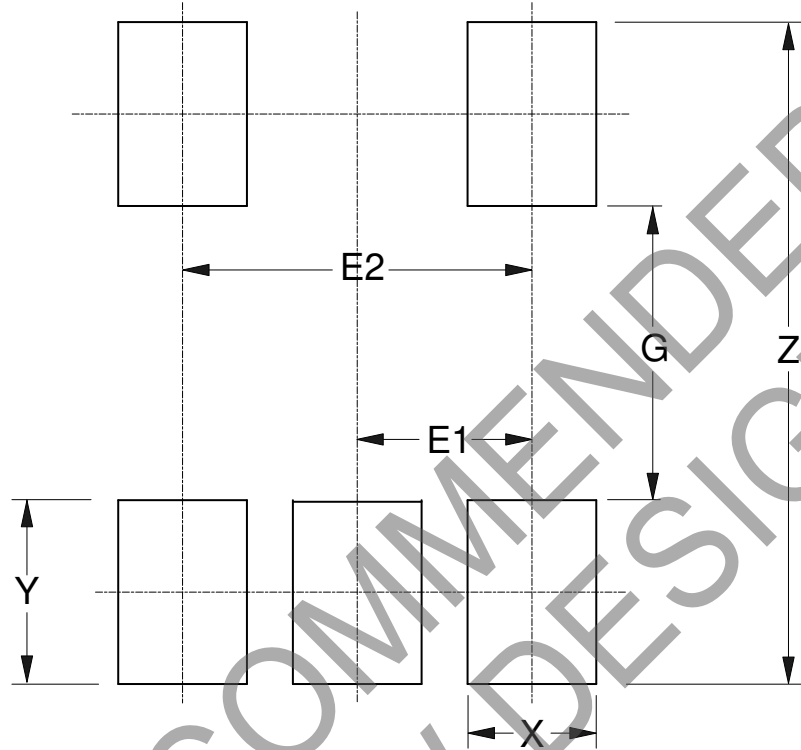

Dimensions	Z (mm)/(inch)	G (mm)/(inch)	X (mm)/(inch)	Y (mm)/(inch)	E1 (mm)/(inch)	E2 (mm)/(inch)
Value	3.600/0.142	1.600/0.063	0.700/0.028	1.000/0.039	0.950/0.037	1.900/0.075

NOT RECOMMENDED FOR NEW DESIGN

Suggested Pad Layout (continued)

Please see <http://www.diodes.com/package-outlines.html> for the latest version.

(2) Package Type: W-DFN2020-6 (Type US)

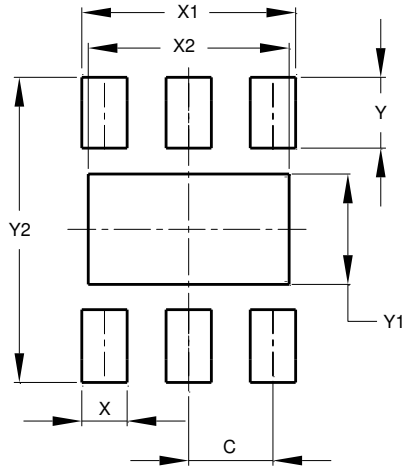

Dimensions	Value (in mm)
C	0.650
X	0.350
X1	1.650
X2	1.550
Y	0.545
Y1	0.850
Y2	2.350

NOT RECOMMENDED FOR NEW DESIGN

IMPORTANT NOTICE

DIODES INCORPORATED MAKES NO WARRANTY OF ANY KIND, EXPRESS OR IMPLIED, WITH REGARDS TO THIS DOCUMENT, INCLUDING, BUT NOT LIMITED TO, THE IMPLIED WARRANTIES OF MERCHANTABILITY AND FITNESS FOR A PARTICULAR PURPOSE (AND THEIR EQUIVALENTS UNDER THE LAWS OF ANY JURISDICTION).

Diodes Incorporated and its subsidiaries reserve the right to make modifications, enhancements, improvements, corrections or other changes without further notice to this document and any product described herein. Diodes Incorporated does not assume any liability arising out of the application or use of this document or any product described herein; neither does Diodes Incorporated convey any license under its patent or trademark rights, nor the rights of others. Any Customer or user of this document or products described herein in such applications shall assume all risks of such use and will agree to hold Diodes Incorporated and all the companies whose products are represented on Diodes Incorporated website, harmless against all damages.

Diodes Incorporated does not warrant or accept any liability whatsoever in respect of any products purchased through unauthorized sales channel. Should Customers purchase or use Diodes Incorporated products for any unintended or unauthorized application, Customers shall indemnify and hold Diodes Incorporated and its representatives harmless against all claims, damages, expenses, and attorney fees arising out of, directly or indirectly, any claim of personal injury or death associated with such unintended or unauthorized application.

Products described herein may be covered by one or more United States, international or foreign patents pending. Product names and markings noted herein may also be covered by one or more United States, international or foreign trademarks.

This document is written in English but may be translated into multiple languages for reference. Only the English version of this document is the final and determinative format released by Diodes Incorporated.

LIFE SUPPORT

Diodes Incorporated products are specifically not authorized for use as critical components in life support devices or systems without the express written approval of the Chief Executive Officer of Diodes Incorporated. As used herein:

A. Life support devices or systems are devices or systems which:

1. are intended to implant into the body, or
2. support or sustain life and whose failure to perform when properly used in accordance with instructions for use provided in the labeling can be reasonably expected to result in significant injury to the user.

B. A critical component is any component in a life support device or system whose failure to perform can be reasonably expected to cause the failure of the life support device or to affect its safety or effectiveness.

Customers represent that they have all necessary expertise in the safety and regulatory ramifications of their life support devices or systems, and acknowledge and agree that they are solely responsible for all legal, regulatory and safety-related requirements concerning their products and any use of Diodes Incorporated products in such safety-critical, life support devices or systems, notwithstanding any devices- or systems-related information or support that may be provided by Diodes Incorporated. Further, Customers must fully indemnify Diodes Incorporated and its representatives against any damages arising out of the use of Diodes Incorporated products in such safety-critical, life support devices or systems.

Copyright © 2019, Diodes Incorporated

www.diodes.com