

## Low voltage 16-bit constant current LED sink driver with output error detection

Datasheet - production data

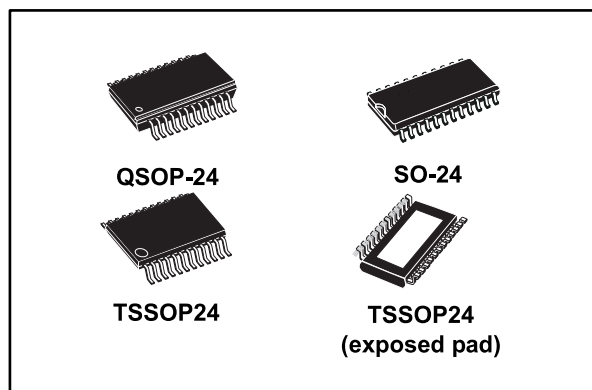

feeds a 16-bit D-type storage register. In the output stage, sixteen regulated current sources were designed to provide 5-100 mA constant current to drive the LEDs.

The STP16DPS05 features open and short LED detections on the outputs. The STP16DPS05 is backward compatible with STP16C/L596. The detection circuit checks 3 different conditions that can occur on the output line: short to GND, short to  $V_O$  or open line.

The data detection results are loaded in the shift register and shifted out via the serial line output.

The detection functionality is implemented without increasing the pin count number, through a secondary function of the LATCH and output enable pin (DM1 and DM2 respectively), a dedicated logic sequence allows the device to enter or leave from detection mode. Through an external resistor, users can adjust the STP16DPS05 output current, controlling in this way the light intensity of LEDs, in addition, user can adjust LED's brightness intensity from 0% to 100% via  $\overline{OE/DM2}$  pin.

The STP16DPS05 guarantees a 20 V output driving capability, allowing users to connect more LEDs in series. The high clock frequency, 30 MHz, makes the device suitable for high data rate transmission. The 3.3 V voltage supply is well useful for applications that interface any 3.3 V micro. Compared with a standard TSSOP package, the TSSOP exposed pad increases heat dissipation capability by a 2.5 factor.

### Features

- Low voltage power supply down to 3 V
- 16 constant current output channels
- Adjustable output current through external resistor
- Short and open output error detection
- Serial data IN/parallel data OUT
- 3.3 V micro driver-able
- Output current: 20-100 mA
- 30 MHz clock frequency
- Available in high thermal efficiency TSSOP exposed pad
- ESD protection: 2 kV HBM, 200 V MM

### Description

The STP16DPS05 is a monolithic, low voltage, low current power 16-bit shift register designed for LED panel displays. The device contains a 16-bit serial-in, parallel-out shift register that

**Table 1: Device summary**

Order code	Package	Packing
STP16DPS05MTR	SO-24 (tape and reel)	1000 parts per reel
STP16DPS05TTR	TSSOP24 (tape and reel)	2500 parts per reel
STP16DPS05XTTR	TSSOP24 exposed pad (tape and reel)	2500 parts per reel
STP16DPS05PTR	QSOP-24	2500 parts per reel

**Contents**

**1 Summary description ..... 3**

    1.1 Pin connection and description ..... 3

**2 Electrical ratings ..... 4**

    2.1 Absolute maximum ratings ..... 4

    2.2 Thermal data ..... 4

    2.3 Recommended operating conditions ..... 5

**3 Electrical characteristics ..... 6**

**4 Equivalent circuit and outputs ..... 8**

**5 Timing diagrams ..... 11**

**6 Typical characteristics ..... 14**

**7 Detection mode functionality ..... 16**

    7.1 Phase one: “entering in detection mode“ ..... 16

    7.2 Phase two: “error detection” ..... 17

    7.3 Phase three: "resuming normal mode" ..... 19

    7.4 Error detection conditions ..... 19

    7.5 Auto power-saving ..... 22

**8 Package information ..... 25**

    8.1 QSOP-24 package information ..... 26

    8.2 TSSOP24 package information ..... 27

    8.3 SO-24 package information ..... 28

    8.4 TSSOP exposed pad package information ..... 30

    8.5 TSSOP24, TSSOP24 exposed pad and  
        SO-24 packing information ..... 32

**9 Revision history ..... 34**

# 1 Summary description

Table 2: Typical current accuracy

Output voltage	Current accuracy		Output current	V <sub>DD</sub>	Temperature
	Between bits	Between ICs			
≥ 1.3 V	± 1.5%	± 5%	20 to 100 mA	3.3 V to 5 V	25 °C

## 1.1 Pin connection and description

Figure 1: Pin connection

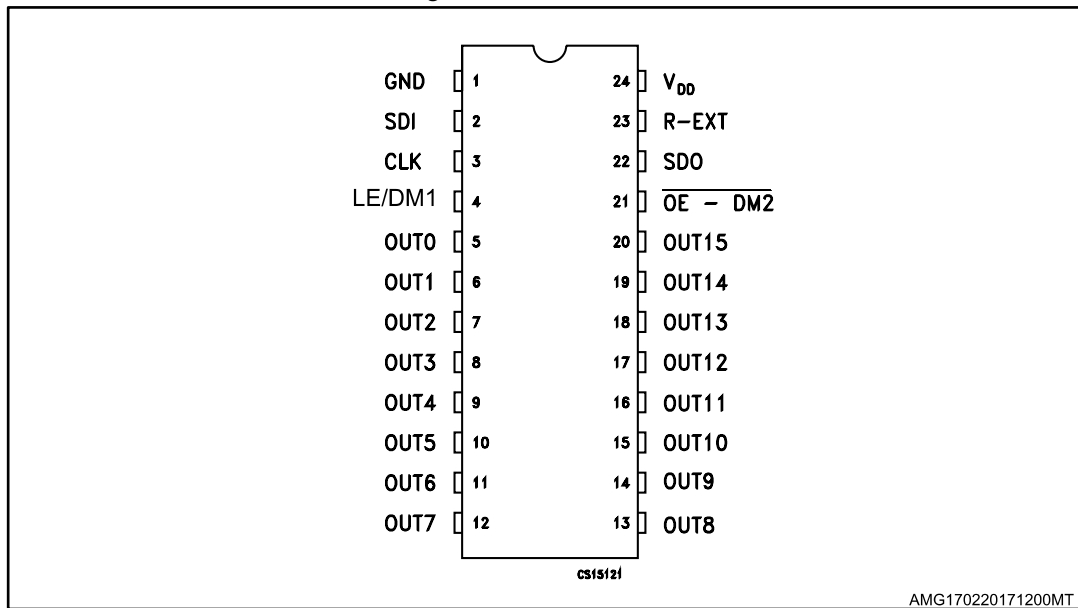

The exposed pad should be electrically connected to a metal land electrically isolated or connected to ground.

Table 3: Pin description

Pin n°	Symbol	Name and function
1	GND	Ground terminal
2	SDI	Serial data input terminal
3	CLK	Clock input terminal
4	LE/DM1	Latch input terminal - detect mode 1 (see operation principle)
5-20	$\overline{\text{OUT 0-15}}$	Output terminal
21	$\overline{\text{OE/DM2}}$	Input terminal of output enable (active low) - detect mode 1 (see operation principle)
22	SDO	Serial data out terminal
23	R-EXT	Input terminal for an external resistor for constant current programming
24	V <sub>DD</sub>	Supply voltage terminal

## 2 Electrical ratings

### 2.1 Absolute maximum ratings

Stressing the device above the rating listed in the [Table 4: "Absolute maximum ratings"](#) may cause permanent damage to the device. These are stress ratings only and operation of the device at these or any other conditions above those indicated in the operating sections of this specification is not implied. Exposure to absolute maximum rating conditions for extended periods may affect device reliability.

**Table 4: Absolute maximum ratings**

Symbol	Parameter	Value	Unit
V <sub>DD</sub>	Supply voltage	0 to 7	V
V <sub>O</sub>	Output voltage	-0.5 to 20	V
I <sub>O</sub>	Output current	100	mA
V <sub>I</sub>	Input voltage	-0.4 to V <sub>DD</sub>	V
I <sub>GND</sub>	GND terminal current	1600	mA
f <sub>CLK</sub>	Clock frequency	50	MHz
T <sub>J</sub>	Junction temperature range <sup>(1)</sup>	-40 to + 170	°C

**Notes:**

<sup>(1)</sup> Such absolute value is achieved according the thermal shutdown.

### 2.2 Thermal data

**Table 5: Thermal data**

Symbol	Parameter	Value	Unit	
T <sub>OPR</sub>	Operating temperature range	-40 to +125	°C	
T <sub>STG</sub>	Storage temperature range	-55 to +150	°C	
R <sub>thJA</sub>	Thermal resistance junction-ambient <sup>(1)</sup>	SO-24	42.7	°C/W
		TSSOP24	55	°C/W
		TSSOP24 <sup>(2)</sup> exposed pad	37.5	°C/W
		QSOP-24	55	°C/W

**Notes:**

<sup>(1)</sup> According with JEDEC JESD51-7.

<sup>(2)</sup> The exposed pad should be soldered directly to the PCB to obtain the thermal benefits.

## 2.3 Recommended operating conditions

Table 6: Recommended operating conditions

Symbol	Parameter	Test conditions	Min.	Typ.	Max.	Unit
V <sub>DD</sub>	Supply voltage		3	-	5.5	V
V <sub>O</sub>	Output voltage			-	20	V
I <sub>O</sub>	Output current	OUT <sub>n</sub>	5	-	100	mA
I <sub>OH</sub>	Output current	SERIAL-OUT		-	+1	mA
I <sub>OL</sub>	Output current	SERIAL-OUT		-	-1	mA
V <sub>IH</sub>	Input voltage		0.7 V <sub>DD</sub>	-	V <sub>DD</sub> +0.3	V
V <sub>IL</sub>	Input voltage		-0.3	-	0.3 V <sub>DD</sub>	V
t <sub>wLAT</sub>	LE/DM1 pulse width	V <sub>DD</sub> = 3.0 V to 5.0 V	6	-		ns
t <sub>wCLK</sub>	CLK pulse width		8	-		ns
t <sub>wEN</sub>	$\overline{\text{OE/DM2}}$ pulse width		100	-		ns
t <sub>SETUP(D)</sub>	Setup time for DATA		10	-		ns
t <sub>HOLD(D)</sub>	Hold time for DATA		5	-		ns
t <sub>SETUP(L)</sub>	Setup time for LATCH		10	-		ns
f <sub>CLK</sub>	Clock frequency		Cascade operation <sup>(1)</sup>		-	30

### Notes:

<sup>(1)</sup> If the device is connected in cascade, it may not be possible to achieve the maximum data transfer. Please consider the timings carefully.

### 3 Electrical characteristics

$V_{DD} = 5\text{ V}$ ,  $T_A = 25\text{ °C}$ , unless otherwise specified.

**Table 7: Electrical characteristics**

Symbol	Parameter	Test conditions	Min.	Typ.	Max.	Unit
$V_{IH}$	Input voltage high level		$0.7 V_{DD}$		$V_{DD}$	V
$V_{IL}$	Input voltage low level		GND		$0.3 V_{DD}$	V
$I_{OH}$	Output leakage current	$V_{OH} = 20\text{ V}$			1	$\mu\text{A}$
$V_{OL}$	Output voltage (serial-OUT)	$I_{OL} = 1\text{ mA}$			0.4	V
$V_{OH}$	Output voltage (serial-OUT)	$I_{OH} = -1\text{ mA}$	$V_{OH} - V_{DD} = -0.4\text{ V}$			V
$I_{OL1}$	Output current	$V_O = 0.3\text{ V}$ , $R_{ext} = 3.9\text{ k}\Omega$	4.25	5	5.75	
$I_{OL2}$		$V_O = 0.3\text{ V}$ , $R_{ext} = 970\ \Omega$	19	20	21	
$I_{OL3}$		$V_O = 1.3\text{ V}$ , $R_{ext} = 190\ \Omega$	96	100	104	mA
$\Delta I_{OL1}$	Output current error between bit (all output ON)	$V_O = 0.3\text{ V}$ , $R_{ext} = 3.9\text{ k}\Omega$		$\pm 5$	$\pm 8$	
$\Delta I_{OL2}$		$V_O = 0.3\text{ V}$ , $R_{ext} = 970\ \Omega$		$\pm 1.5$	$\pm 3$	%
$\Delta I_{OL3}$		$V_O = 1.3\text{ V}$ , $R_{ext} = 190\ \Omega$		$\pm 1.2$	$\pm 3$	
$R_{SIN(up)}$	Pull-up resistor		150	300	600	k $\Omega$
$R_{SIN(down)}$	Pull-down resistor		100	200	400	k $\Omega$
$I_{DD(OFF1)}$	Supply current (OFF)	$R_{ext} = 970$ OUT 0 to 15 = OFF		5	6	mA
$I_{DD(OFF2)}$		$R_{ext} = 240$ OUT 0 to 15 = OFF		13	14	
$I_{DD(ON1)}$	Supply current (ON)	$R_{ext} = 970$ OUT 0 to 15 = ON		6	7	
$I_{DD(ON2)}$		$R_{ext} = 240$ OUT 0 to 15 = ON		13.5	14.5	
Thermal	Thermal protection <sup>(1)</sup>			170		$^{\circ}\text{C}$

**Notes:**

<sup>(1)</sup> Guaranteed by design (not tested). The thermal protection switches OFF only the outputs current.

$V_{DD} = 5\text{ V}$ ,  $T_A = 25\text{ }^\circ\text{C}$ , unless otherwise specified.

Table 8: Switching characteristics

Symbol	Parameter	Test conditions	Min.	Typ.	Max.	Unit	
$t_{PLH1}$	Propagation delay time, CLK- $\overline{\text{OUTn}}$ , LE/DM1 = H, $\overline{\text{OE/DM2}} = \text{L}$	$V_{IH} = V_{DD}$ $V_{IL} = \text{GND}$ $C_L = 10\text{ pF}$ $I_O = 20\text{ mA}$ $V_L = 3.0\text{ V}$ $R_{ext} = 1\text{ K}\Omega$ $R_L = 60\text{ }\Omega$	$V_{DD} = 3.3\text{ V}$	-	40 to 44	44	ns
			$V_{DD} = 5\text{ V}$	-	20 to 44	44	
$t_{PLH2}$	Propagation delay time, LE/DM1- $\overline{\text{OUTn}}$ , $\overline{\text{OE/DM2}} = \text{L}$		$V_{DD} = 3.3\text{ V}$	-	51	77	ns
			$V_{DD} = 5\text{ V}$	-	32	47	
$t_{PLH3}$	Propagation delay time, $\overline{\text{OE/DM2}} - \overline{\text{OUTn}}$ , LE = H		$V_{DD} = 3.3\text{ V}$	-	49 to 57	57 to 77	ns
			$V_{DD} = 5\text{ V}$	-	27 to 32	32 to 41	
$t_{PLH}$	Propagation delay time, CLK-SDO		$V_{DD} = 3.3\text{ V}$	-	21.5 to 22	32	ns
			$V_{DD} = 5\text{ V}$	-	14.5 to 15	21.5	
$t_{PHL1}$	Propagation delay time, CLK- $\overline{\text{OUTn}}$ , LE/DM1 = H, $\overline{\text{OE/DM2}} = \text{L}$		$V_{DD} = 3.3\text{ V}$	-	15 to 18	25	ns
			$V_{DD} = 5\text{ V}$	-	11 to 13	14.5 to 16	
$t_{PHL2}$	Propagation delay time, LE/DM1 - $\overline{\text{OUTn}}$ , $\overline{\text{OE/DM2}} = \text{L}$	$V_{DD} = 3.3\text{ V}$	-	13 to 18	18 to 25	ns	
		$V_{DD} = 5\text{ V}$	-	9 to 12	12.5 to 15		
$t_{PHL3}$	Propagation delay time, $\overline{\text{OE/DM2}} - \overline{\text{OUTn}}$ , LE/DM1 = H	$V_{DD} = 3.3\text{ V}$	-	11.5 to 12	12 to 18	ns	
		$V_{DD} = 5\text{ V}$	-	8.5 to 10	9.7 to 12		
$t_{PHL}$	Propagation delay time, CLK-SDO	$V_{DD} = 3.3\text{ V}$	-	25.5	38	ns	
		$V_{DD} = 5\text{ V}$	-	17.5 to 20.5	25		
$t_{ON}$	Output rise time 10~90% of voltage waveform	$V_{DD} = 3.3\text{ V}$	-	34 to 20	24 to 53.5	ns	
		$V_{DD} = 5\text{ V}$	-	12.5 to 9	9 to 18.5		
$t_{OFF}$	Output fall time 90~10% of voltage waveform	$V_{DD} = 3.3\text{ V}$	-	5.5 to 3.3	3.3 to 8.5	ns	
		$V_{DD} = 5\text{ V}$	-	4.5 to 2.8	2.8 to 6.5		
$t_r$	CLK rise time <sup>(1)</sup>		-		5000	ns	
$t_f$	CLK fall time <sup>(1)</sup>		-		5000	ns	

**Notes:**

<sup>(1)</sup> In order to achieve high cascade data transfer, please consider  $t_r/t_f$  timings carefully.

## 4 Equivalent circuit and outputs

Figure 2: OE/DM2 terminal

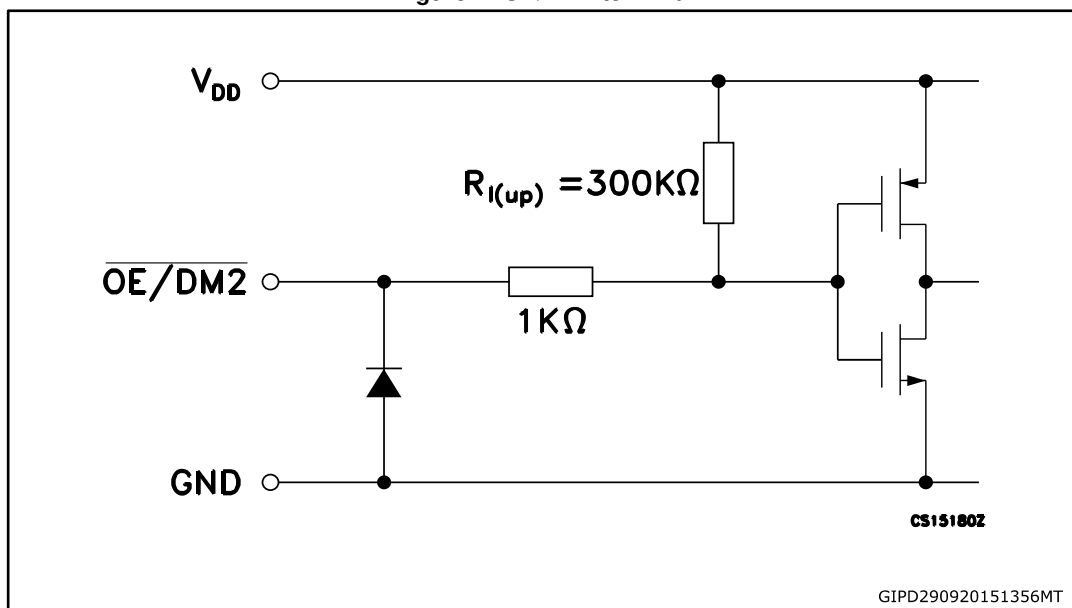

Figure 3: LE/DM1 terminal

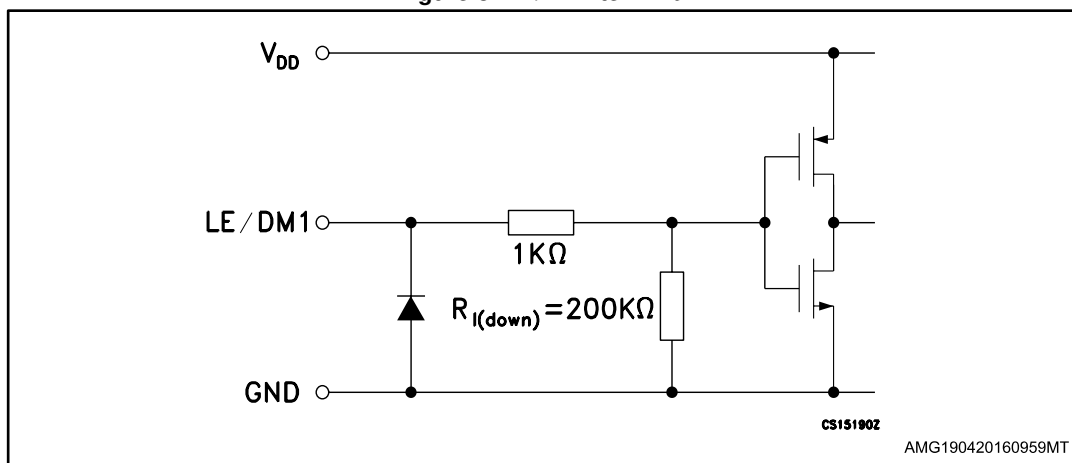



Figure 4: CLK, SDI terminal

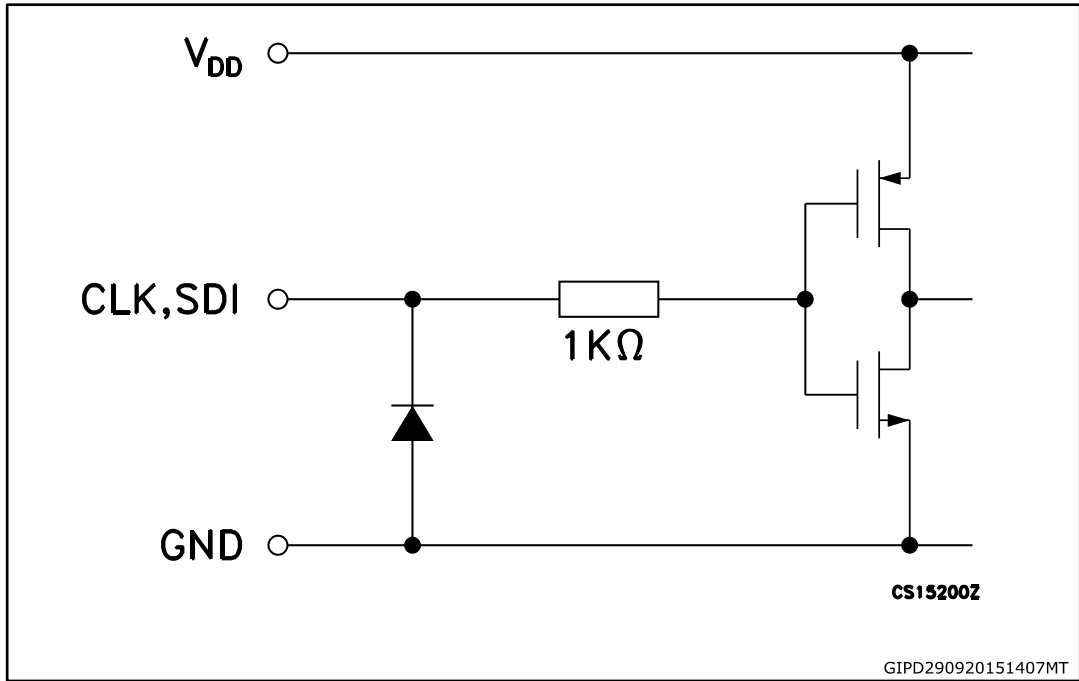

Figure 5: SDO terminal

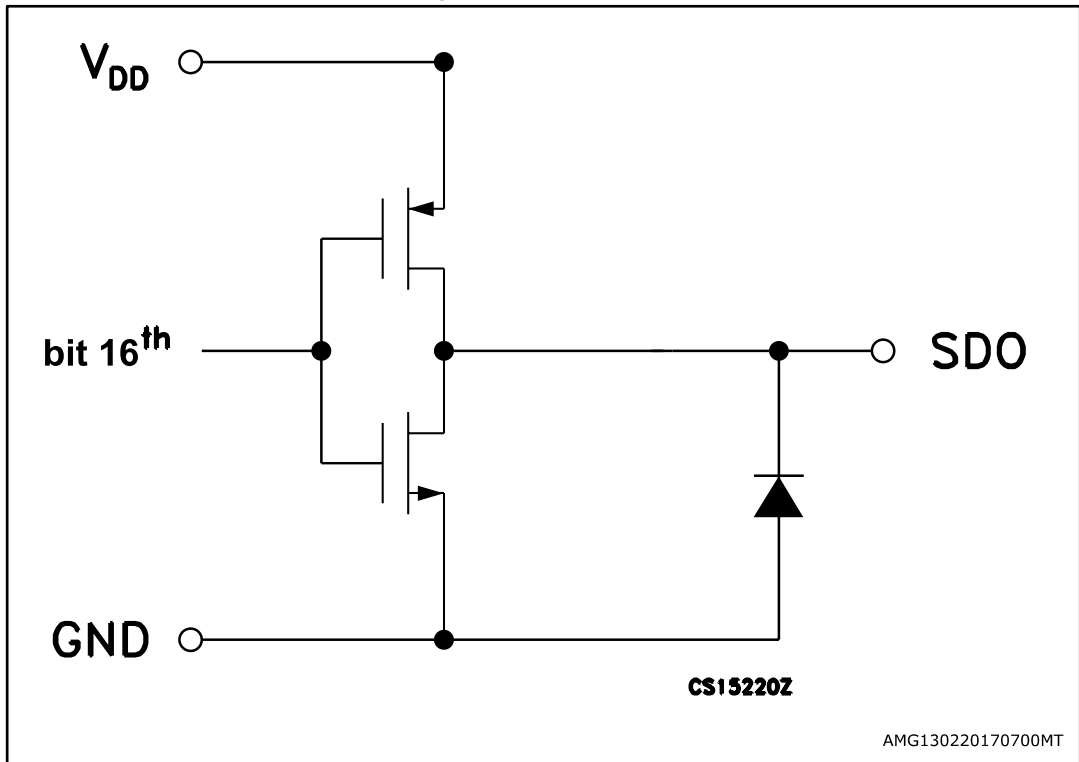
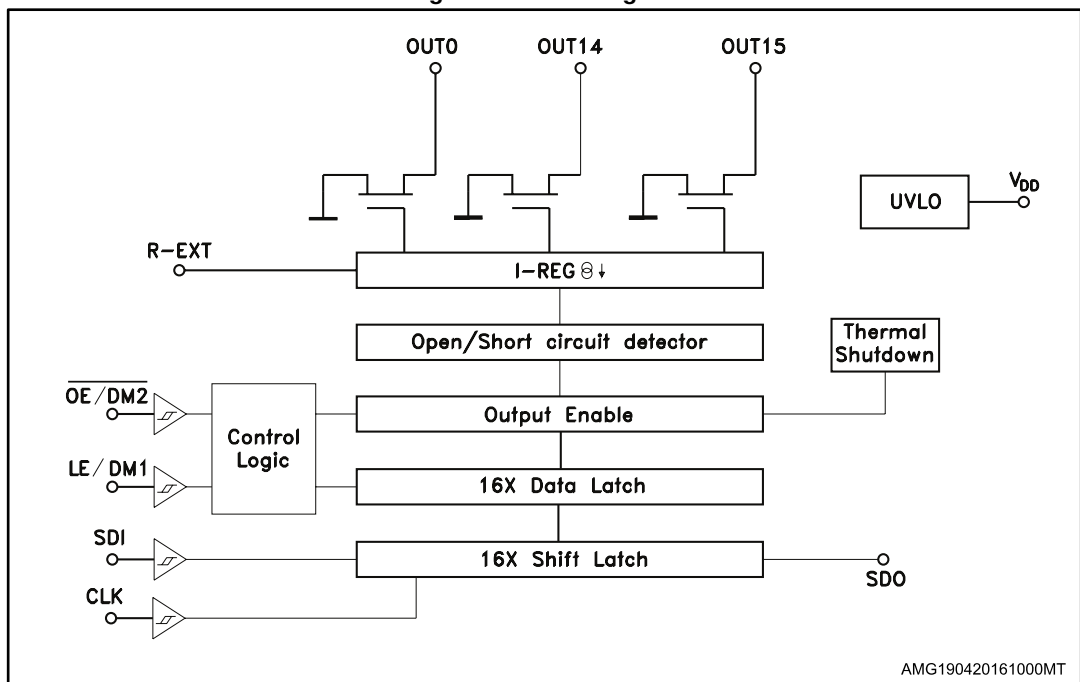

Figure 6: Block diagram



# 5 Timing diagrams

Table 9: Truth table

CLOCK	LE/DM1	OE/DM2	SERIAL-IN	OUT0 ..... OUT7 ..... OUT15	SDO
┌┐	H	L	Dn	Dn ..... Dn - 7 ..... Dn -15	Dn - 15
┌┐	L	L	Dn + 1	No change	Dn - 14
┌┐	H	L	Dn + 2	Dn + 2 ..... Dn - 5 ..... Dn -13	Dn - 13
┐┌	X	L	Dn + 3	Dn + 2 ..... Dn - 5 ..... Dn -13	Dn - 13
┐┌	X	H	Dn + 3	OFF	Dn - 13



OUTn = ON when Dn = H OUTn = OFF when Dn = L.

Figure 7: Timing diagram

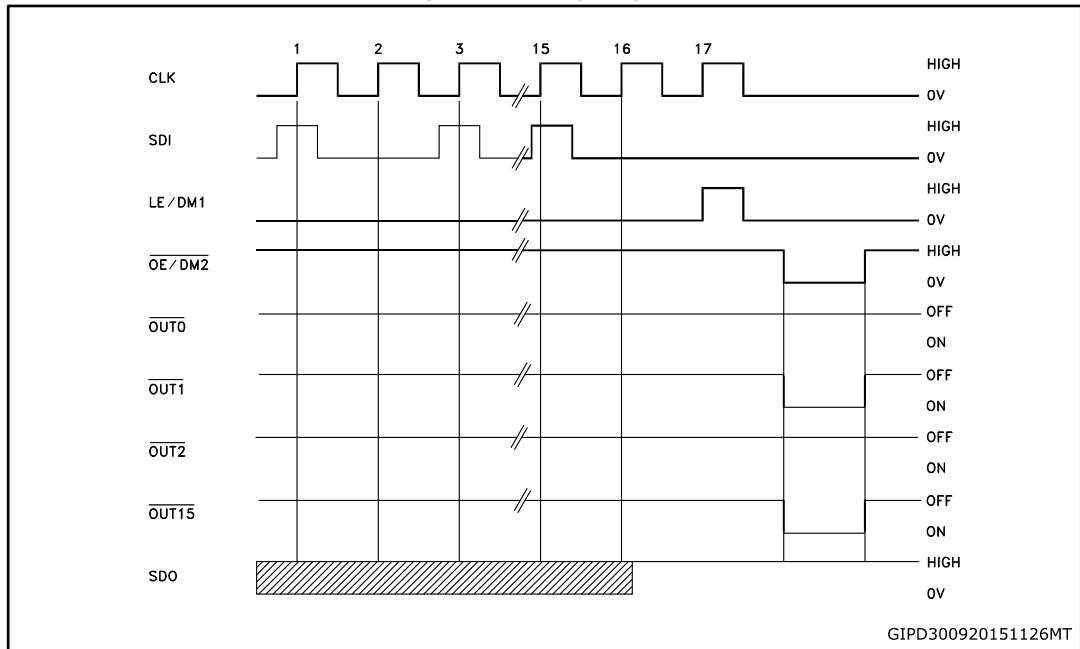

- 1 Latch and output enable are level sensitive and ARE NOT synchronized with rising-or-falling edge of CLK signal.
- 2 When LE/DM1 terminal is low level, the latch circuits hold previous set of data.
- 3 When LE/DM1 terminal is high level, the latch circuits refresh new set of data from SDI chain.
- 4 When OE/DM2 terminal is at low level, the output terminals - Out0 to Out15 respond to data in the latch circuits, either '1' for ON or '0' for OFF.
- 5 When OE/DM2 terminal is at high level, all output terminals will be switched OFF.

Figure 8: Clock, serial-in, serial-out

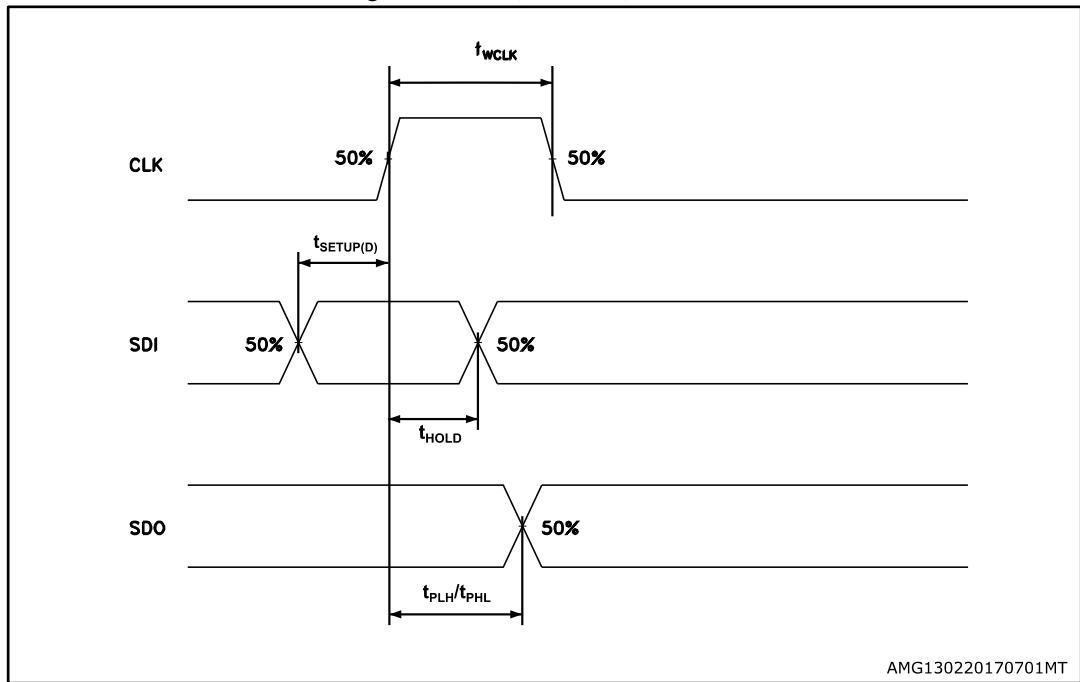

Figure 9: Clock, serial-in, latch, enable, outputs

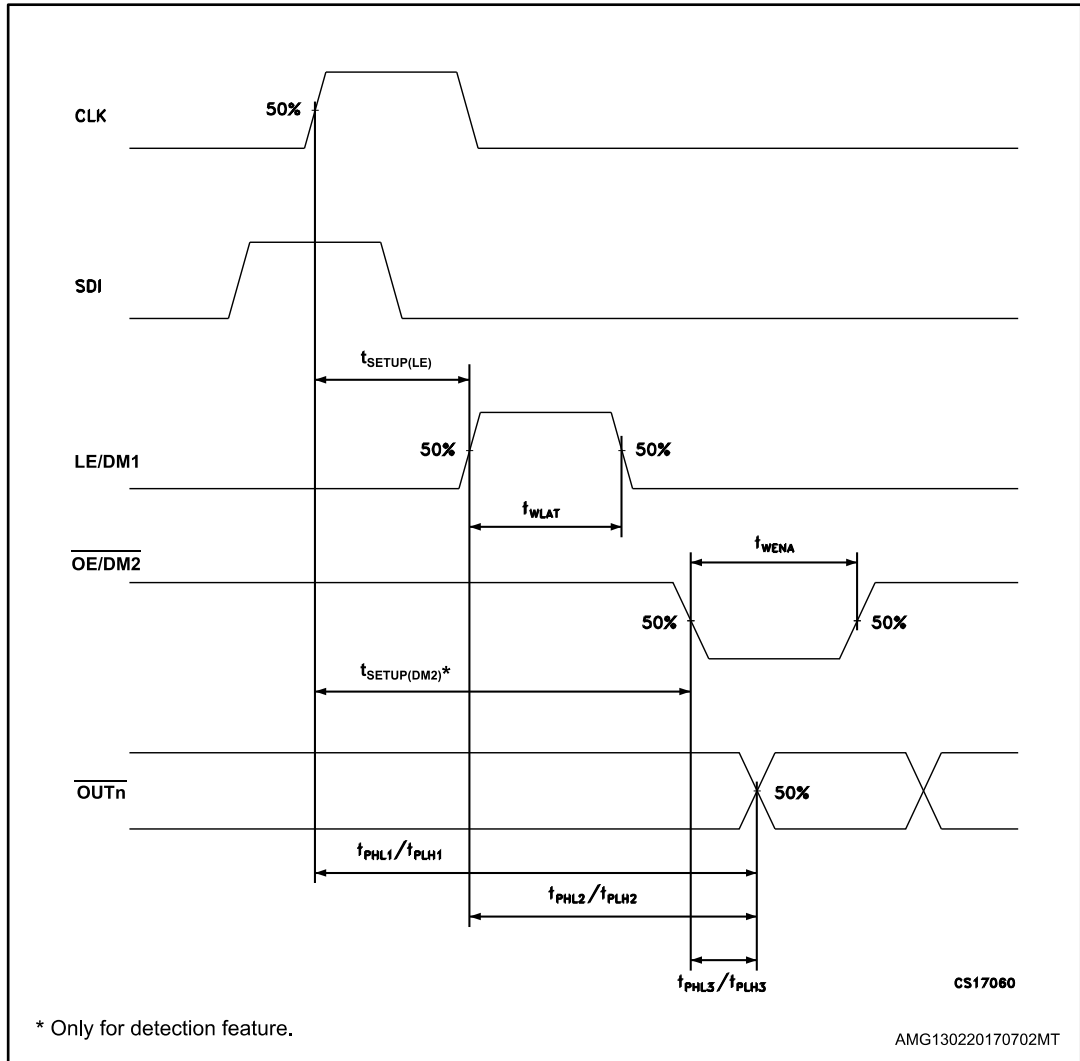
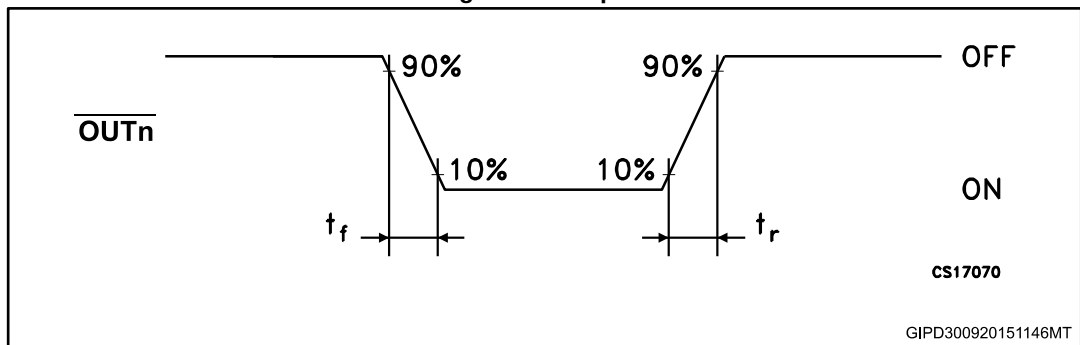

Figure 10: Outputs



## 6 Typical characteristics

Figure 11: Output current-R-EXT resistor

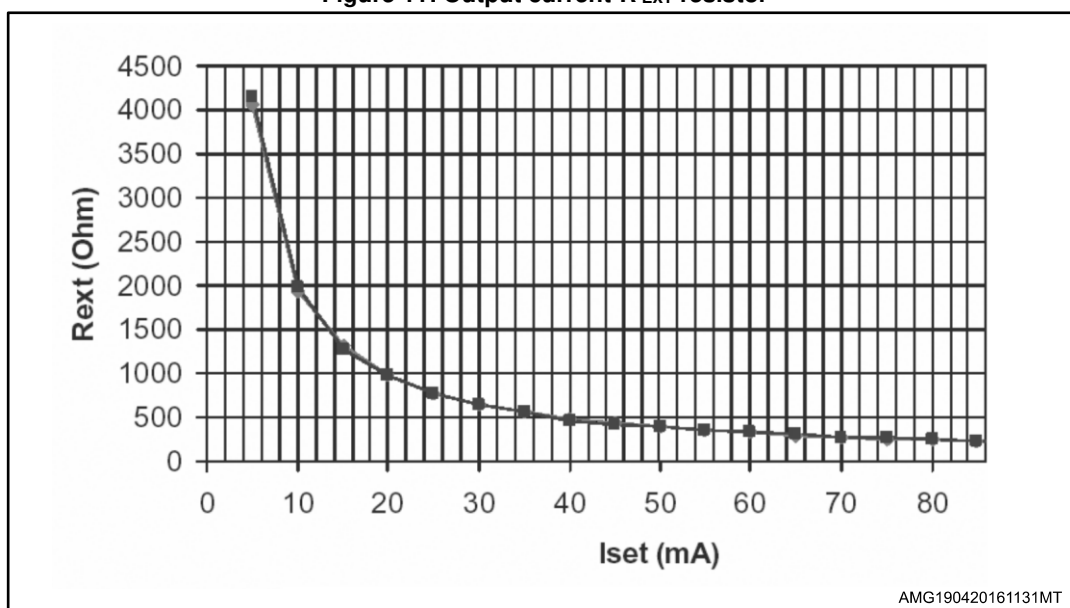

Table 10: Output current-R-EXT resistor

R-EXT (Ω)	Output current (mA)
976	20
780	25
652	30
560	35
488	40
433	45
389	50
354	55
325	60
300	65
278	70
259	75
241	80
229	85

Conditions:

temperature = 25 °C, V<sub>DD</sub> = 3.3 V; 5.0 V, I<sub>SET</sub> = 3 mA; 5 mA; 10 mA; 20 mA; 50 mA; 80 mA.

Figure 12: I<sub>SET</sub> vs dropout voltage (V<sub>drop</sub>)

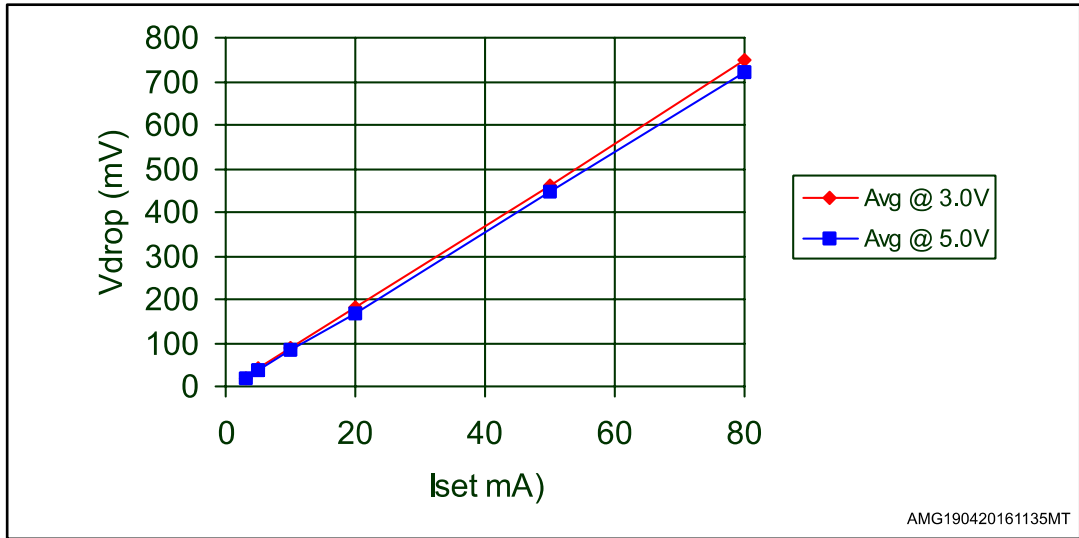
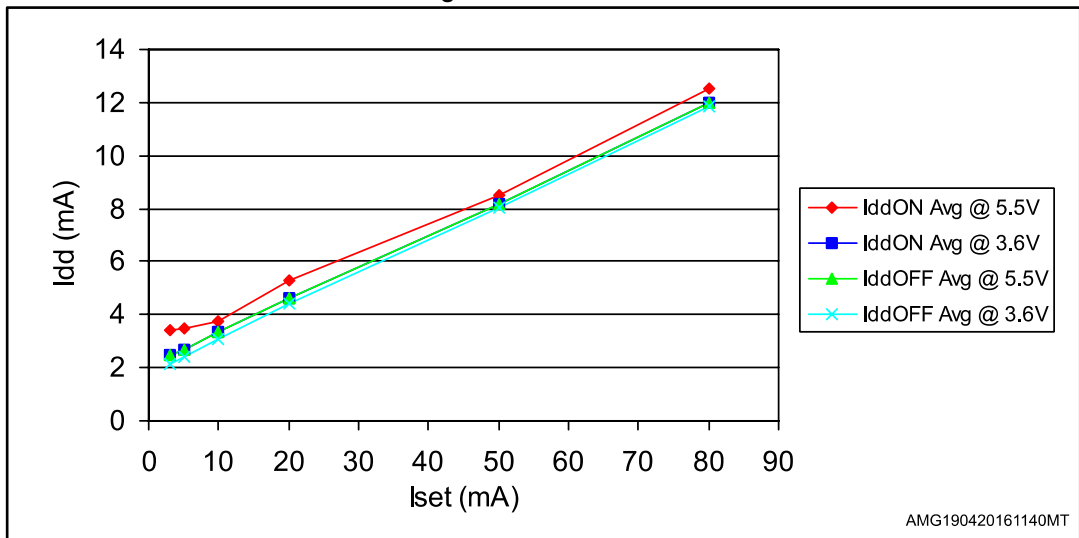

Table 11: I<sub>SET</sub> vs dropout voltage (V<sub>drop</sub>)

I <sub>out</sub> (mA)	Avg @ 3.0 V	Avg @ 5.0 V
3	19.33	22.66
5	36.67	40.33
10	77.33	80
20	158.67	157.33
50	406	406
80	692	668

Figure 13: I<sub>DD</sub> ON/OFF



## 7 Detection mode functionality

### 7.1 Phase one: “entering in detection mode“

From the “normal mode” condition the device can switch to the “error mode” by a logic sequence on the  $\overline{\text{OE/DM2}}$  and LE/DM1 pins as showed in the following table and diagram:

Table 12: Entering in detection truth table

CLK	1°	2°	3°	4°	5°
$\overline{\text{OE/DM2}}$	H	L	H	H	H
LE/DM1	L	L	L	H	L

Figure 14: Entering in detection timing diagram

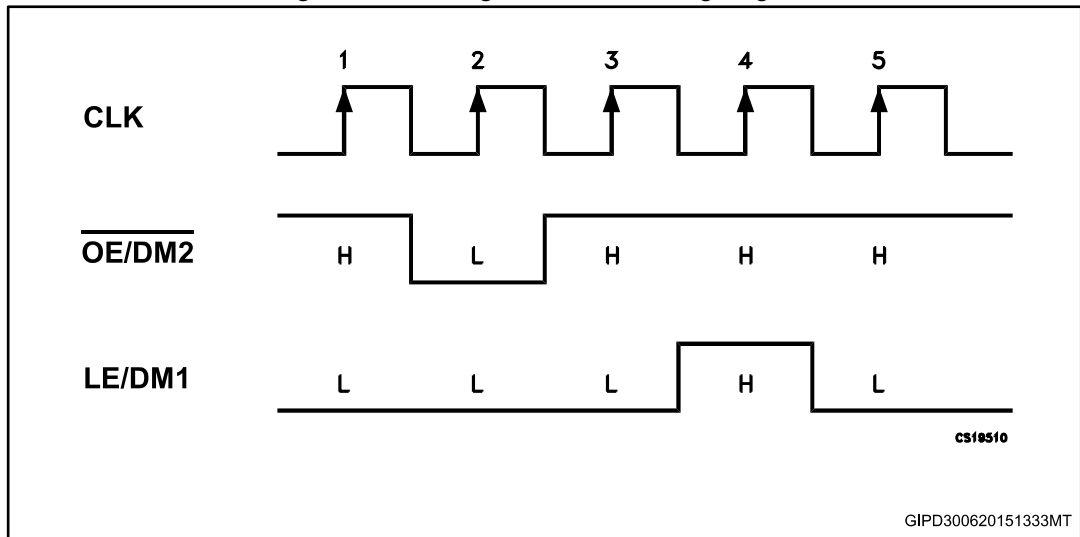

After these five CLK cycles the device goes into the “error detection mode” and at the 6<sup>th</sup> rise front of CLK the SDI data are ready for the sampling.



### 7.2 Phase two: “error detection”

The 16 data bits must be set “1” in order to set ON all the outputs during the detection. The data are latched by LE/DM1 and after that the outputs are ready for the detection process. When the microcontroller switches the  $\overline{OE/DM2}$  to LOW, the device drives the LEDs in order to analyze if an OPEN or SHORT condition has occurred.

Figure 15: Detection diagram

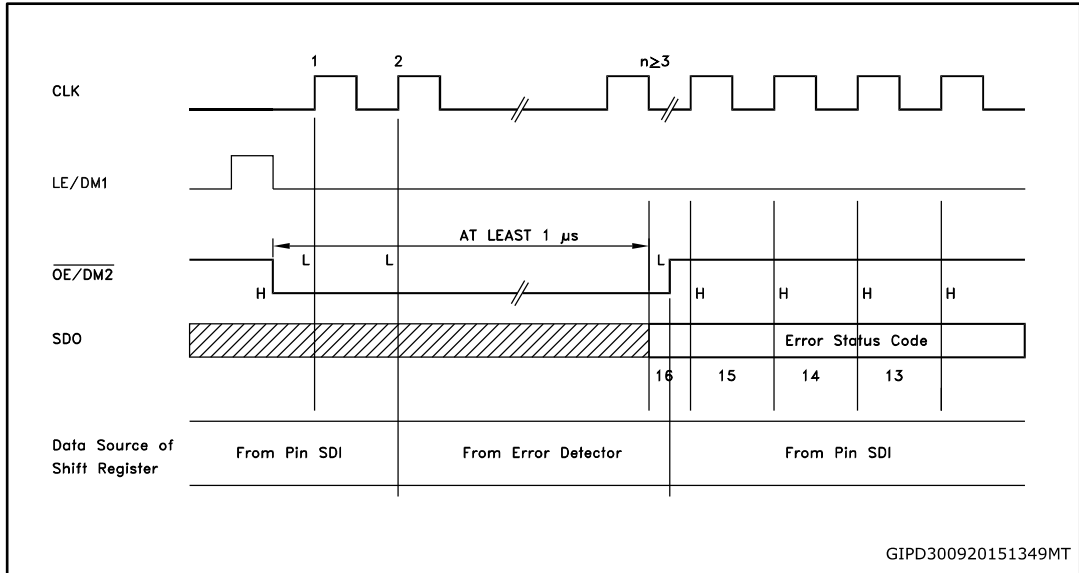

The LEDs status will be detected at least in 1 microsecond and after this time the microcontroller sets  $\overline{OE/DM2}$  in HIGH state and the output data detection result will go to the microprocessor via SDO.

Detection mode and normal mode use both the same format data. As soon as all the detection data bits are available on the serial line, the device may go back to normal mode of operation. To re-detect the status the device must go back in normal mode and reentering in error detection mode.

Figure 16: Timing example for open and/or short-circuit detection

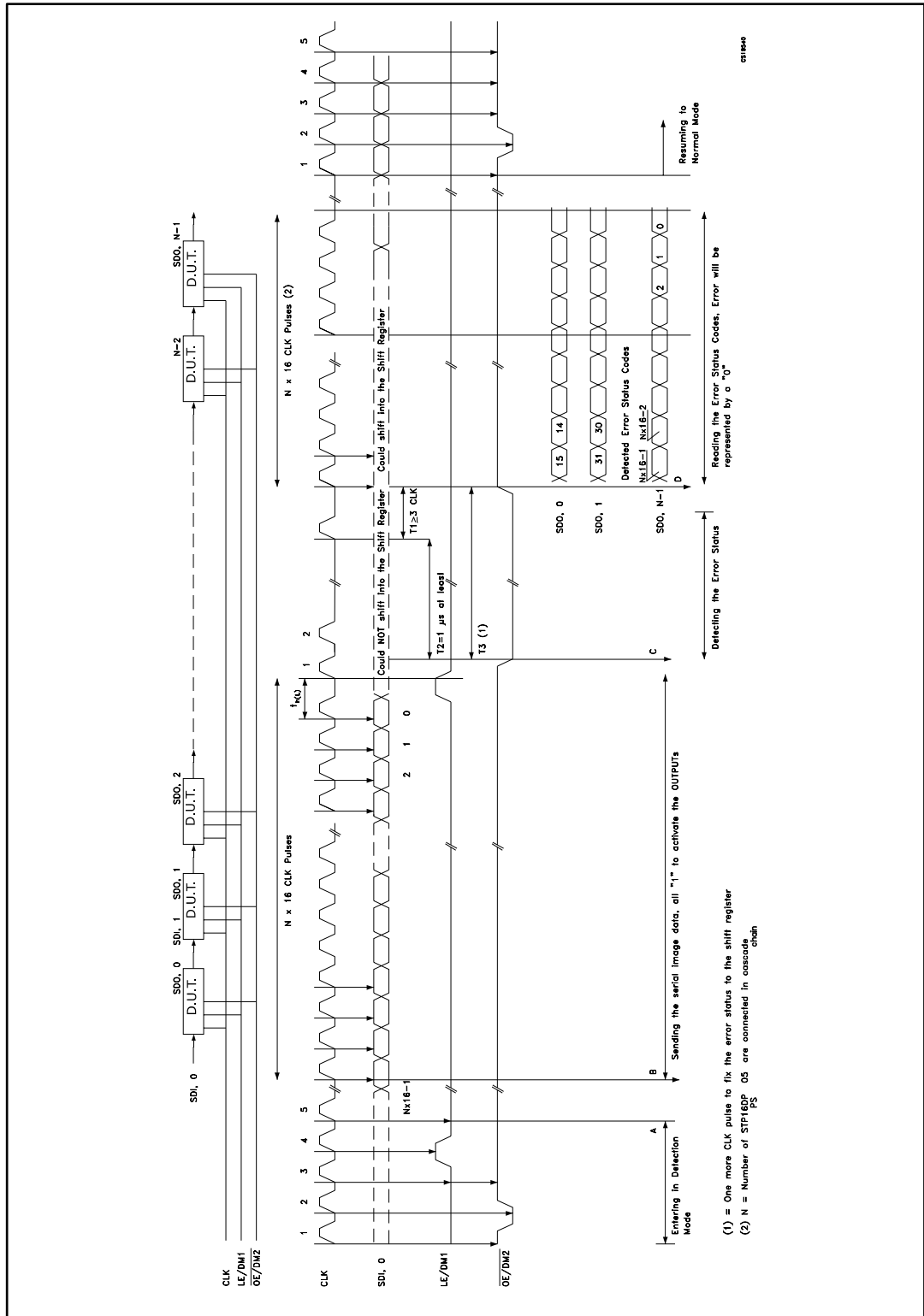

### 7.3 Phase three: "resuming normal mode"

The sequence for reentering normal mode is shown in the following table:

**Table 13: Resuming to normal mode timing diagram**

CLK	1°	2°	3°	4°	5°
$\overline{\text{OE/DM2}}$	H	L	H	H	H
LE/DM1	L	L	L	L	L



For proper device operation the "Entering in detection" sequence must be followed by a "resume mode" sequence, it is not possible to insert consecutive equal sequence.

### 7.4 Error detection conditions

$V_{DD} = 3.3$  to  $5$  V temperature range  $-40$  to  $125$  °C.

**Table 14: Detection conditions**

Configuration	Detect mode	Detection results		
SW-1 or SW-3b	Open line or output short to GND detected	$\implies I_{ODEC} \leq 0.5 \times I_O$	No error detected	$\implies I_{ODEC} \geq 0.5 \times I_O$
SW-2 or SW-3a	Short on LED or short to V-LED detected	$\implies V_O \geq 2.4$ V	No error detected	$\implies V_O \leq 2.2$ V



Where:  $I_O$  = the output current programmed by the  $R_{EXT}$ ,  $I_{ODEC}$  = the detected output current in detection mode.

Figure 17: Detection circuit

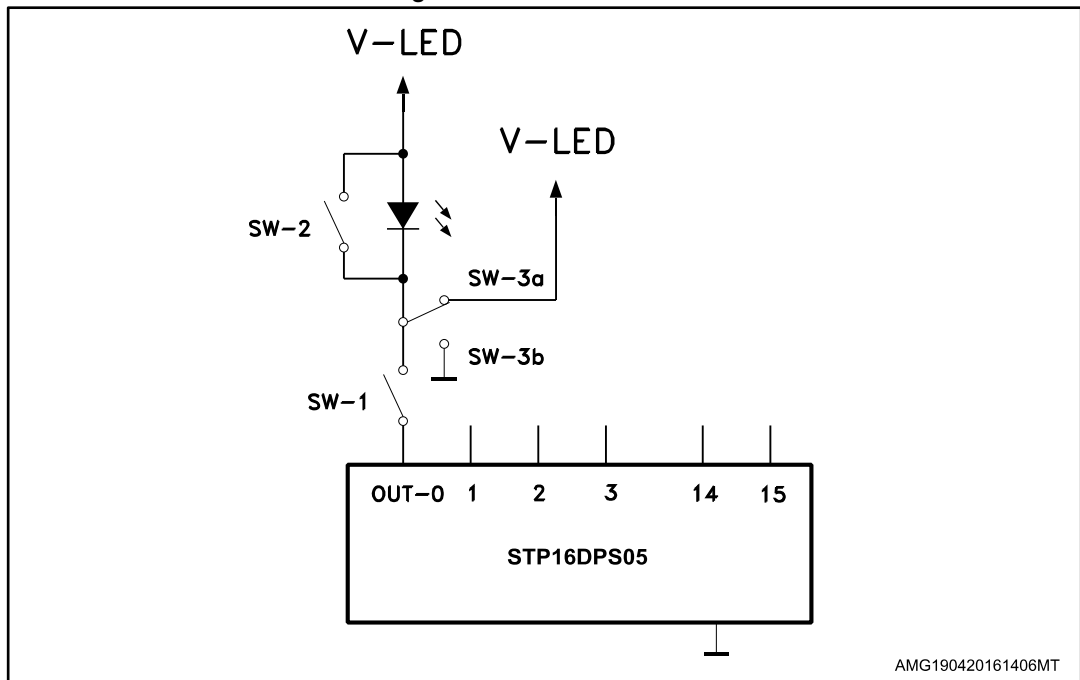

AMG190420161406MT

Figure 18: Error detection sequence

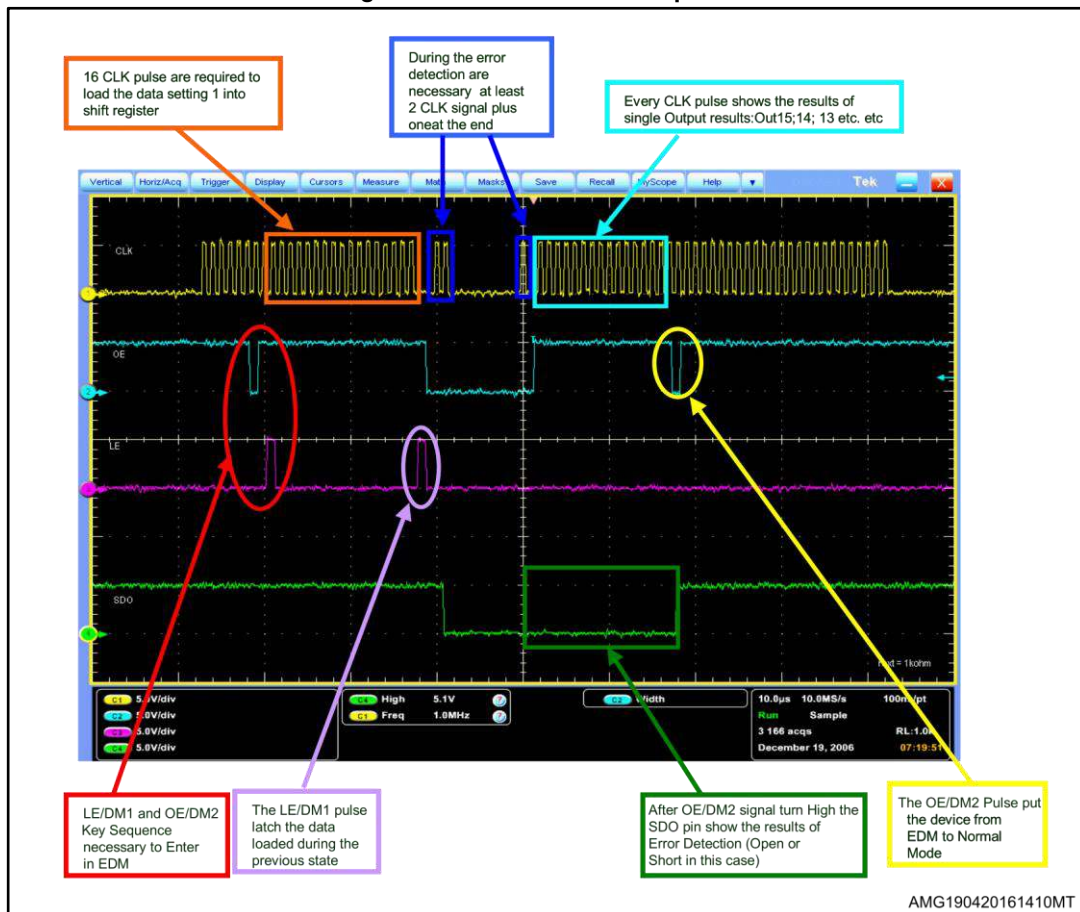

AMG190420161410MT

Typical schematic used to perform the error detection:

Figure 19: Error detection typical schematic

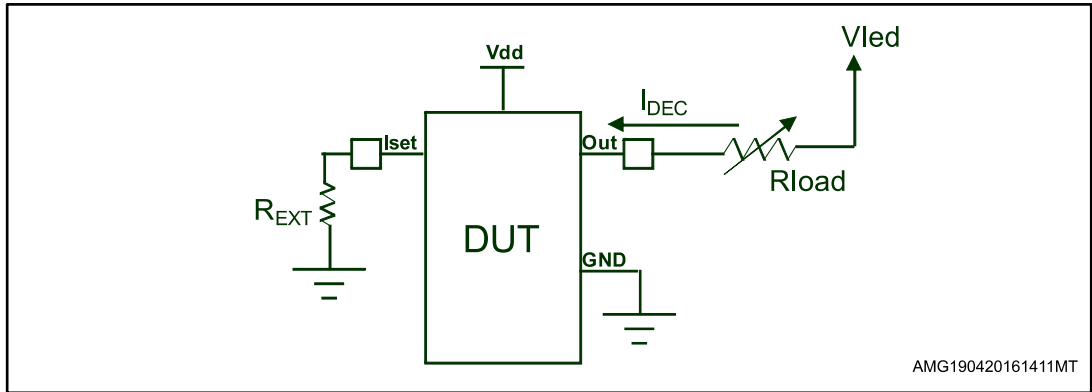

Using the follow formula is possible measure the I<sub>odec</sub>.

$$I_{ODEC} = (V_{led} - V_{load}) / R_{load}$$

The tables below shows the I<sub>ODEC</sub> average value at 3.3 V and 5.0 V of power supply voltage.

The I<sub>ODEC</sub> is the current value recognized by the devices output open error detection.

Table 15: I<sub>ODEC</sub> average value at 3.3 V

Vdd (V)	Iset (mA)	R <sub>ext</sub> (Ω)	I <sub>out</sub> AVG (mA)
3.3	5	4270	2.097
	10	2056	6.79
	20	1006	10.46
	50	382	26.92
	80	251	35.03

Table 16: I<sub>ODEC</sub> average value at 5 V

Vdd (V)	Iset (mA)	R <sub>ext</sub> (Ω)	I <sub>out</sub> AVG (mA)
5	5	4270	1.98
	10	2056	6.09
	20	1006	9.67
	50	382	25.54
	80	251	38.9

## 7.5 Auto power-saving

The auto power-saving feature minimizes the quiescent current if no active data is detected on the latches and auto powers-up the device as the first active data is latched.

Figure 20: Auto power-saving feature

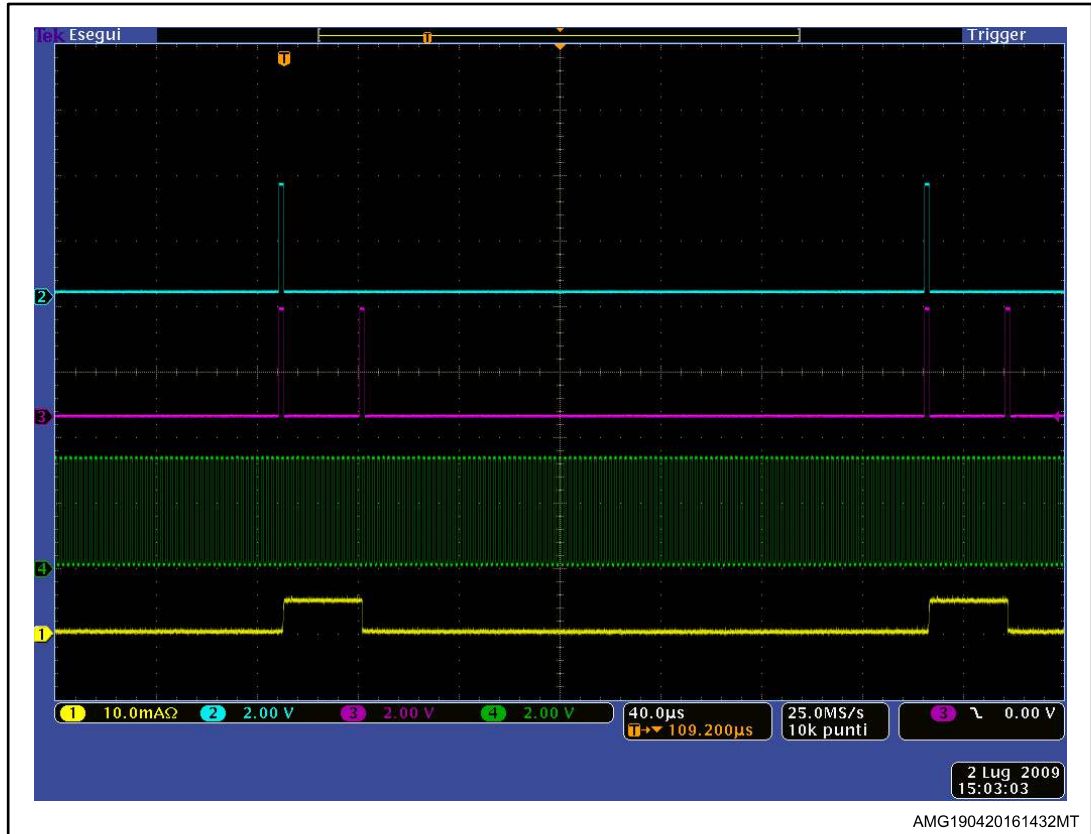

Conditions:

Temp. = 25 °C, Vdd = 3.3 V, Vin = Vdd, VLed = 3.0 V, Iset = 20 mA

Ch1 (Yellow) = IDD, Ch2 (Blue) = SDI, Ch3 (Purple) = LE/DM1, Ch4 (Green) = CLK

I<sub>dd</sub> consumption:

I<sub>dd</sub> (normal operation) = 5.15 mA

p<sub>dd</sub> (shutdown condition) = 163 µA

Figure 21: Delay LE-OUT

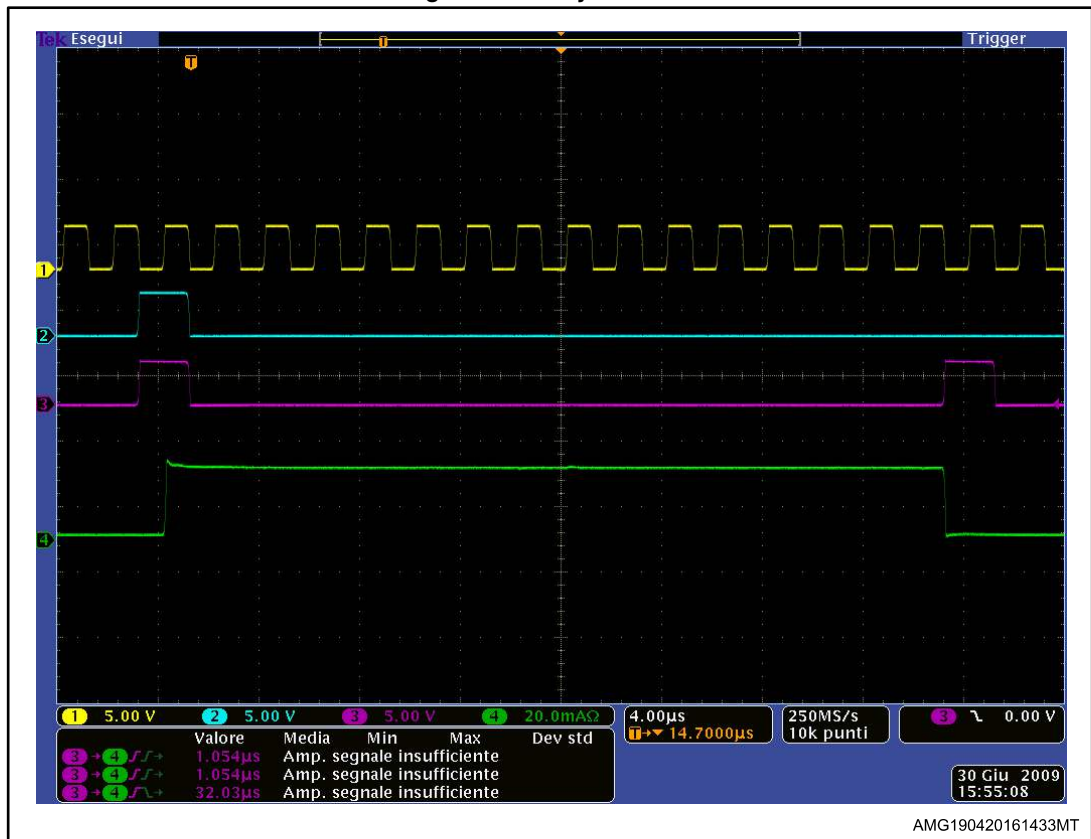

After 16 clock cycles without data change, device will enter in Auto power save mode as expected. Delay TLE-OUT = 1.053 µs

Conditions:

Temp. = 25 °C, Vdd = 3.3 V, Vin = Vdd, VLed = 3.0 V, Iset = 20 mA

Ch1 (Yellow) = CLK, Ch2 (Blue) = SDI, Ch3 (Purple) = LE/DM1, Ch4 (Green) = IOUT

Figure 22: Behaviour auto power saving



When the device goes from auto power-saving to normal operating condition, the first output that switches ON shows the TON condition as seen in the plot above.

Temp. = 25°C, Vdd = 3.3 V, Vin = Vdd, VLed = 3.0 V, Iset = 20 mA

Ch1 (Yellow) = IDD, Ch2 (Blue) = SDI, Ch3 (Purple) = LE/DM1, Ch4 (Green) = CLK



## 8 Package information

In order to meet environmental requirements, ST offers these devices in different grades of ECOPACK® packages, depending on their level of environmental compliance. ECOPACK® specifications, grade definitions and product status are available at: [www.st.com](http://www.st.com). ECOPACK® is an ST trademark.

### 8.1 QSOP-24 package information

Figure 23: QSOP-24 package outline

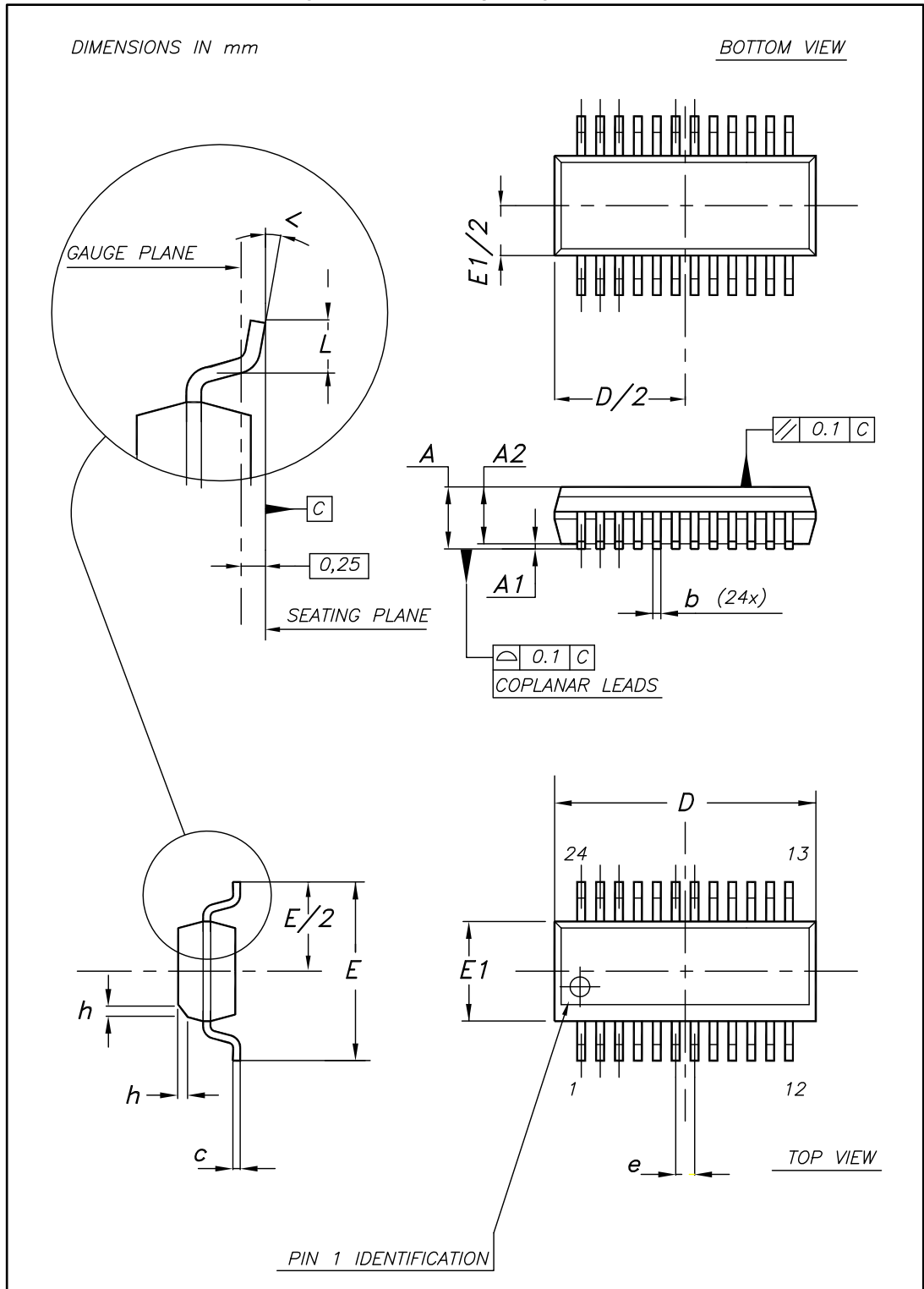

Table 17: QSOP-24 mechanical data

Dim.	mm		
	Min.	Typ.	Max.
A	1.54	1.62	1.73
A1	0.10	0.15	0.25
A2		1.47	
b	0.20		0.31
c	0.17		0.254
D	8.56	8.66	8.76
E	5.80	6.00	6.20
E1	3.80	3.91	4.01
e		0.635	
L	0.40	0.635	0.89
h	0.25	0.33	0.41
<	0°		8°

## 8.2 TSSOP24 package information

Figure 24: TSSOP24 package outline

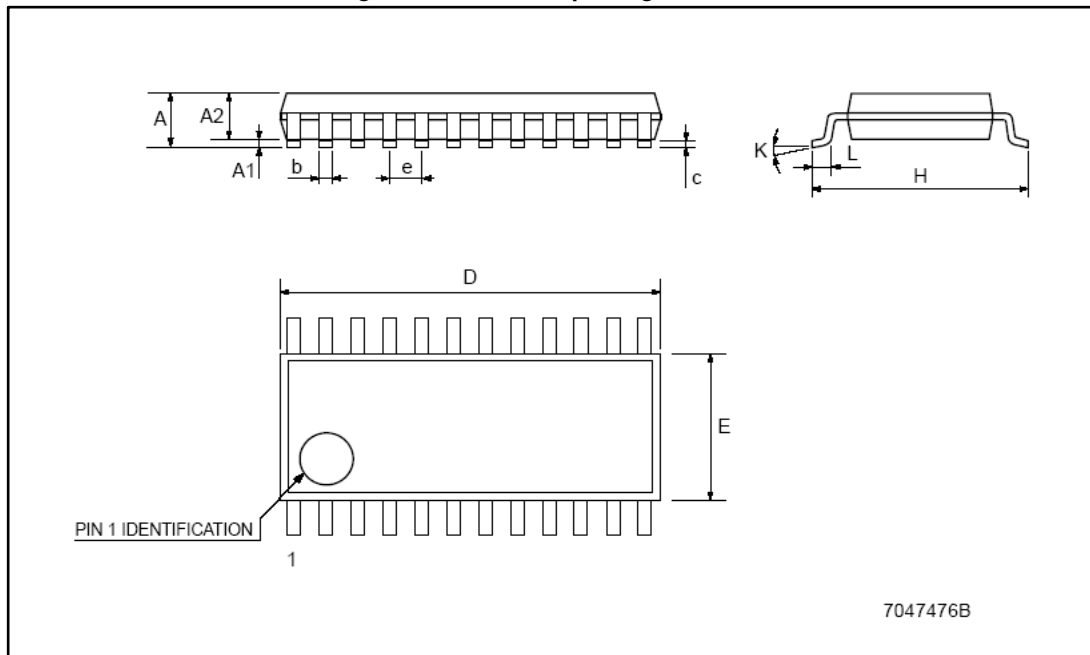

Table 18: TSSOP24 mechanical data

Dim.	mm		
	Min.	Typ.	Max.
A			1.1
A1	0.05		0.15
A2		0.9	
b	0.19		0.30
c	0.09		0.20
D	7.7		7.9
E	4.3		4.5
e		0.65 BSC	
H	6.25		6.5
K	0°		8°
L	0.50		0.70

### 8.3 SO-24 package information

Figure 25: SO-24 package outline

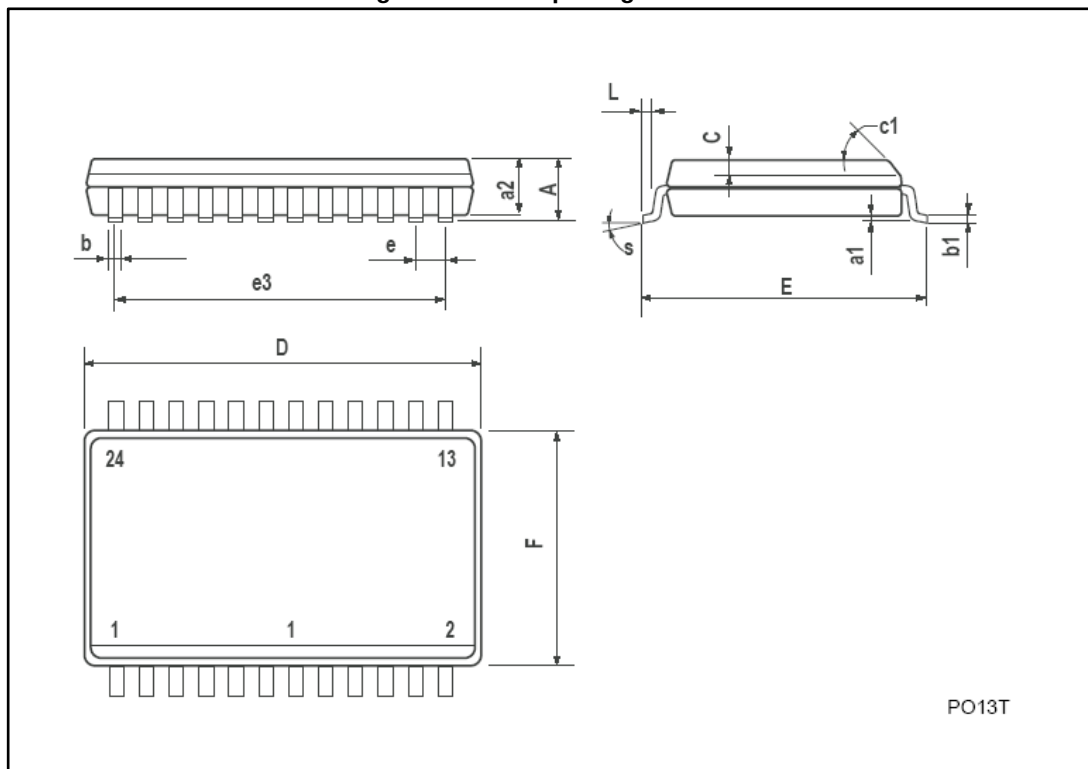

Table 19: SO-24 mechanical data

Dim.	mm		
	Min.	Typ.	Max.
A			2.65
a1	0.1		0.2
a2			2.45
b	0.35		0.49
b1	0.23		0.32
C		0.5	
c1	45° (typ.)		
D	15.20		15.60
E	10.00		10.65
e		1.27	
e3		13.97	
F	7.40		7.60
L	0.50		1.27
S	°(max.) 8		

### 8.4 TSSOP exposed pad package information

Figure 26: TSSOP24 exposed pad package outline

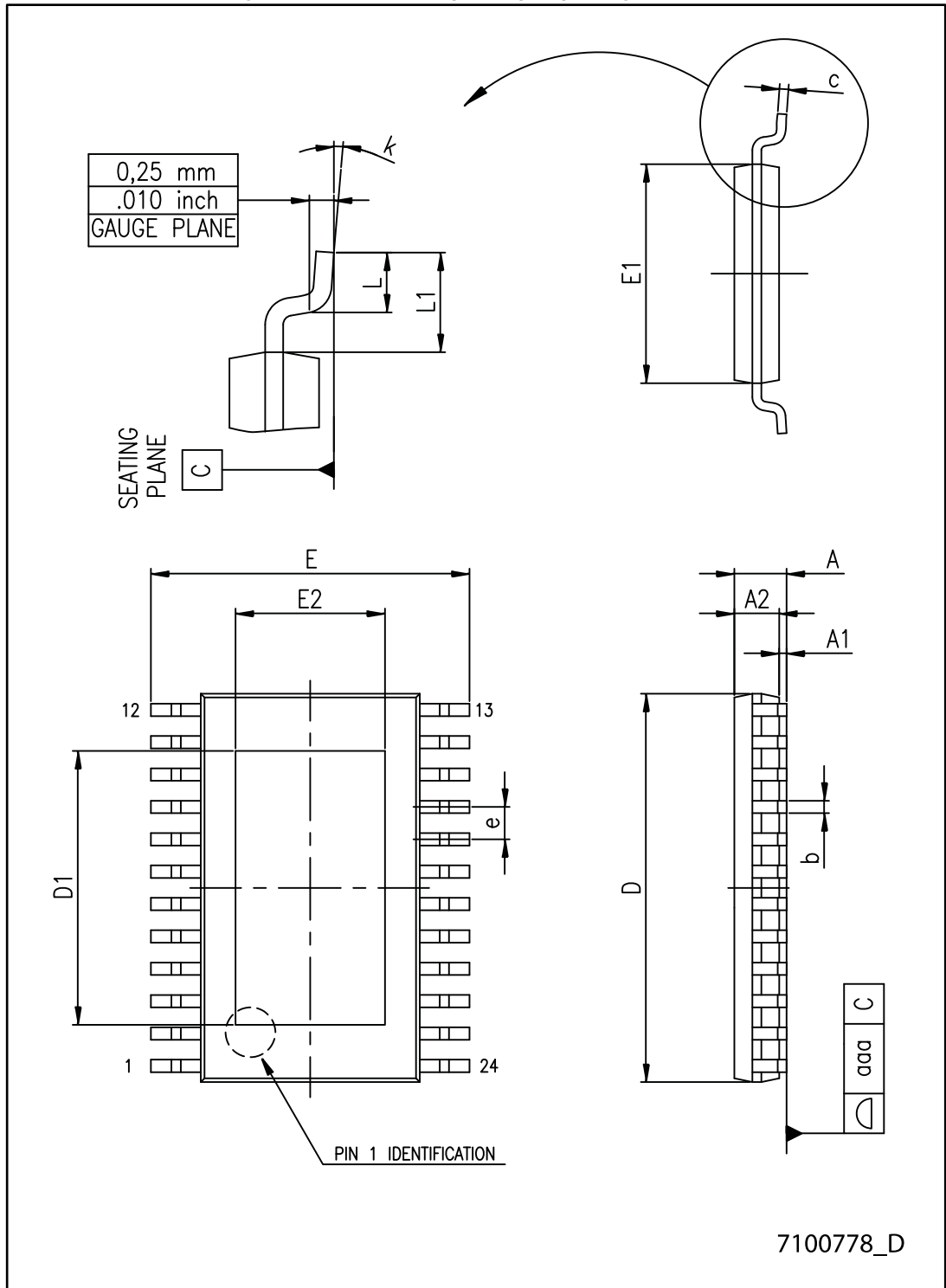

Table 20: TSSOP24 exposed pad mechanical data

Dim.	mm		
	Min.	Typ.	Max.
A			1.20
A1			0.15
A2	0.80	1.00	1.05
b	0.19		0.30
c	0.09		0.20
D	7.70	7.80	7.90
D1	4.80	5.00	5.2
E	6.20	6.40	6.60
E1	4.30	4.40	4.50
E2	3.00	3.20	3.40
e		0.65	
L	0.45	060	075
L1		1.00	
k	0°		8°
aaa			0.10

### 8.5 TSSOP24, TSSOP24 exposed pad and SO-24 packing information

Figure 27: TSSOP24, TSSOP24 exposed pad and SO-24 reel outline

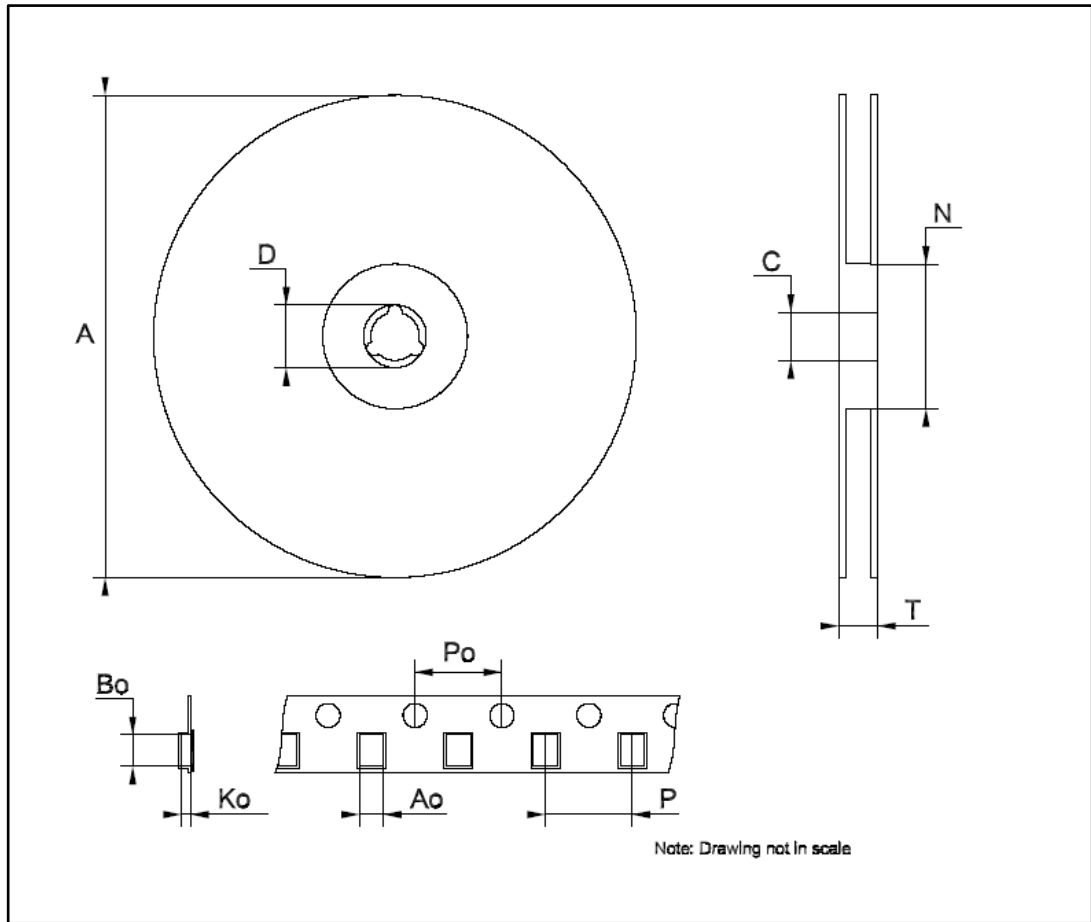

Table 21: TSSOP24 and TSSOP24 exposed pad tape and reel mechanical data

Dim.	mm		
	Min.	Typ.	Max.
A		-	330
C	12.8	-	13.2
D	20.2	-	
N	60	-	
T		-	22.4
Ao	6.8	-	7
Bo	8.2	-	8.4
Ko	1.7	-	1.9
Po	3.9	-	4.1
P	11.9	-	12.1



Table 22: SO-24 tape and reel mechanical data

Dim.	mm		
	Min.	Typ.	Max.
A		-	330
C	12.8	-	13.2
D	20.2	-	
N	60	-	
T		-	30.4
Ao	10.8	-	11.0
Bo	15.7	-	15.9
Ko	2.9	-	3.1
Po	3.9	-	4.1
P	11.9	-	12.1

## 9 Revision history

**Table 23: Document revision history**

Date	Revision	Changes
23-Oct-2009	1	First release
22-Jan-2010	2	Updated Table 5 on page 4
13-Apr-2017	3	Updated features in cover page, <i>Figure 5: "SDO terminal"</i> , <i>Figure 8: "Clock, serial-in, serial-out"</i> , <i>Figure 9: "Clock, serial-in, latch, enable, outputs"</i> and <i>Section 8.1: "QSOP-24 package information"</i> . Minor text changes.

**IMPORTANT NOTICE – PLEASE READ CAREFULLY**

STMicroelectronics NV and its subsidiaries ("ST") reserve the right to make changes, corrections, enhancements, modifications, and improvements to ST products and/or to this document at any time without notice. Purchasers should obtain the latest relevant information on ST products before placing orders. ST products are sold pursuant to ST's terms and conditions of sale in place at the time of order acknowledgement.

Purchasers are solely responsible for the choice, selection, and use of ST products and ST assumes no liability for application assistance or the design of Purchasers' products.

No license, express or implied, to any intellectual property right is granted by ST herein.

Resale of ST products with provisions different from the information set forth herein shall void any warranty granted by ST for such product.

ST and the ST logo are trademarks of ST. All other product or service names are the property of their respective owners.

Information in this document supersedes and replaces information previously supplied in any prior versions of this document.

© 2017 STMicroelectronics – All rights reserved