

CMOS Digital Integrated Circuit Silicon Monolithic

TC9594XBG

Overview

Parallel Port to MIPI® DSISM (TC9594XBG) is a bridge device that converts RGB to DSI. All internal registers can be accessed through I²C or SPI.

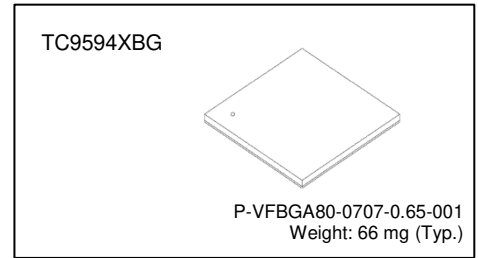

Features

- DSI-TX interface
 - ✧ MIPI® DSI compliant (Version 1.02.00– June 28, 2010)
 - Support DSI Video Mode data transfer
 - DCS Command for panel register access
 - ✧ Supports up to 1 Gbps per data lane
 - ✧ Supports 1, 2, 3 or 4 data lanes
 - ✧ Supports video data formats
 - RGB888/666/565
- RGB interface
 - ✧ Supports data formats
 - 24-bit data bus
 - RGB888/666/565 data formats
 - ✧ Up to 166 MHz input clock
 - ✧ Support VSYNC/HSYNC polarity option (default LOW)
 - ✧ Support DE polarity option (default High)
- I²C/SPI Slave Interface (Option to select either I²C or SPI interface)
 - ✧ I²C Interface (when CS=L)
 - Support for normal (100KHz), fast mode (400 kHz) and Special mode (1 MHz)
 - Configure all TC9594XBG internal registers
 - Writing to DCS registers will trigger DCS Command transmits over DSI
 - ✧ SPI interface (when CS =H)
 - SPI interface support for up to 25 MHz operation.
 - Configure all TC9594XBG internal registers
 - Writing to DCS registers will trigger DCS Command transmits over DSI
- GPIO signals
 - ✧ 2 GPIO signals
 - Two GPIO signals can be configured as SPI signals (SPI_SS and SPI_MISO)
 - Or one GPIO signal can be configured as Interrupt output signal, INT.
- System
 - ✧ Clock and power management support to achieve low power states.
- Power supply inputs
 - ✧ Core and MIPI® D-PHY: 1.2V
 - ✧ I/O: 1.8V or 3.3V
- Typical power consumption
 - ✧ WXGA @60fps: Pixel Clk: 74.25 MHz, DSIClk: 312 MHz → 66.6 mW
 - ✧ 1080P @60fps: Pixel Clk: 148.5 MHz, DSIClk: 471 MHz → 91.4 mW
 - ✧ Power Down Condition is achieved by turning off clock sources: PClk and RefClk.
- Operation temperature range
 - ✧ Ta = -40 °C to 105 °C
- AEC-Q100 qualified with the following definition
 - ✧ Grade 2 : -40 °C to 105 °C ambient operating temperature range

Table of contents

REFERENCES.....	5
1. Overview	6
2. Features	7
3. External Pins	9
3.1. TC9594XBG pinout description.....	9
3.2. TC9594XBG BGA80 Pin Count Summary.....	10
3.3. TC9594XBG Pin Layout.....	11
4. Package	12
4.1. TC9594XBG Package.....	12
5. Electrical Characteristics.....	13
5.1. Absolute Maximum Ratings.....	13
5.2. Operating Condition.....	13
5.3. DC Electrical Specification	14
6. Revision History	15
RESTRICTIONS ON PRODUCT USE.....	16

List of Figures

Figure 1.1 System Overview with TC9594XBG in RGB to DSI-TX.....	6
Figure 3.1 TC9594XBG 80-Pin Layout (Top View).....	11
Figure 4.1 TC9594XBG P-VFBGA80-0707-0.65-001 package.....	12

List of Tables

Table 3.1 TC9594XBG Functional Signal List	9
Table 3.2 TC9594XBG BGA 80 Pin Count Summary	10
Table 4.1 TC9594XBG P-VFBGA80-0707-0.65-001 Mechanical Dimension	12
Table 6.1 Revision History	15

- MIPI® is a registered trademark of MIPI Alliance, Inc. DSISM, DPISM and D-PHYSM are service marks of MIPI Alliance, Inc.
- Other company names, product names, and service names may be trademarks or service names of their respective companies.

1 NOTICE OF DISCLAIMER

2 The material contained herein is not a license, either expressly or impliedly, to any IPR owned or controlled
3 by any of the authors or developers of this material or MIPI. The material contained herein is provided on
4 an "AS IS" basis and to the maximum extent permitted by applicable law, this material is provided AS IS
5 AND WITH ALL FAULTS, and the authors and developers of this material and MIPI hereby disclaim all
6 other warranties and conditions, either express, implied or statutory, including, but not limited to, any (if
7 any) implied warranties, duties or conditions of merchantability, of fitness for a particular purpose, of
8 accuracy or completeness of responses, of results, of workmanlike effort, of lack of viruses, and of lack of
9 negligence.

10 All materials contained herein are protected by copyright laws, and may not be reproduced, republished,
11 distributed, transmitted, displayed, broadcast or otherwise exploited in any manner without the express
12 prior written permission of MIPI Alliance. MIPI, MIPI Alliance and the dotted rainbow arch and all related
13 trademarks, tradenames, and other intellectual property are the exclusive property of MIPI Alliance and
14 cannot be used without its express prior written permission.

15 ALSO, THERE IS NO WARRANTY OF CONDITION OF TITLE, QUIET ENJOYMENT, QUIET
16 POSSESSION, CORRESPONDENCE TO DESCRIPTION OR NON-INFRINGEMENT WITH REGARD
17 TO THIS MATERIAL OR THE CONTENTS OF THIS DOCUMENT. IN NO EVENT WILL ANY
18 AUTHOR OR DEVELOPER OF THIS MATERIAL OR THE CONTENTS OF THIS DOCUMENT OR
19 MIPI BE LIABLE TO ANY OTHER PARTY FOR THE COST OF PROCURING SUBSTITUTE
20 GOODS OR SERVICES, LOST PROFITS, LOSS OF USE, LOSS OF DATA, OR ANY INCIDENTAL,
21 CONSEQUENTIAL, DIRECT, INDIRECT, OR SPECIAL DAMAGES WHETHER UNDER
22 CONTRACT, TORT, WARRANTY, OR OTHERWISE, ARISING IN ANY WAY OUT OF THIS OR
23 ANY OTHER AGREEMENT, SPECIFICATION OR DOCUMENT RELATING TO THIS MATERIAL,
24 WHETHER OR NOT SUCH PARTY HAD ADVANCE NOTICE OF THE POSSIBILITY OF SUCH
25 DAMAGES.

26 Without limiting the generality of this Disclaimer stated above, the user of the contents of this Document is
27 further notified that MIPI: (a) does not evaluate, test or verify the accuracy, soundness or credibility of the
28 contents of this Document; (b) does not monitor or enforce compliance with the contents of this Document;
29 and (c) does not certify, test, or in any manner investigate products or services or any claims of compliance
30 with the contents of this Document. The use or implementation of the contents of this Document may
31 involve or require the use of intellectual property rights ("IPR") including (but not limited to) patents,
32 patent applications, or copyrights owned by one or more parties, whether or not Members of MIPI. MIPI
33 does not make any search or investigation for IPR, nor does MIPI require or request the disclosure of any
34 IPR or claims of IPR as respects the contents of this Document or otherwise.

35 Questions pertaining to this document, or the terms or conditions of its provision, should be addressed to:

36 MIPI Alliance, Inc.
37 c/o IEEE-ISTO
38 445 Hoes Lane
39 Piscataway, NJ 08854
40 Attn: Board Secretary

This Notice of Disclaimer applies to all DSI input and processing paths related descriptions throughout this document.

REFERENCES

1. MIPI DSI, "mipi_DSI_specification_v01-02-00, June 28, 2010"
2. MIPI DCS "DRAFT mipi_DCS_specification_v01-02-00_r0-02, December 2008"
3. MIPI D-PHY, "mipi_D-PHY_specification_v01-00-00, May 14, 2009"
4. I²C bus specification, version 2.1, January 2000, Philips Semiconductor

1. Overview

The Parallel Port to MIPI® DSI (TC9594XBG) is a bridge device that converts RGB to DSI. All internal registers can be accessed through I²C or SPI.

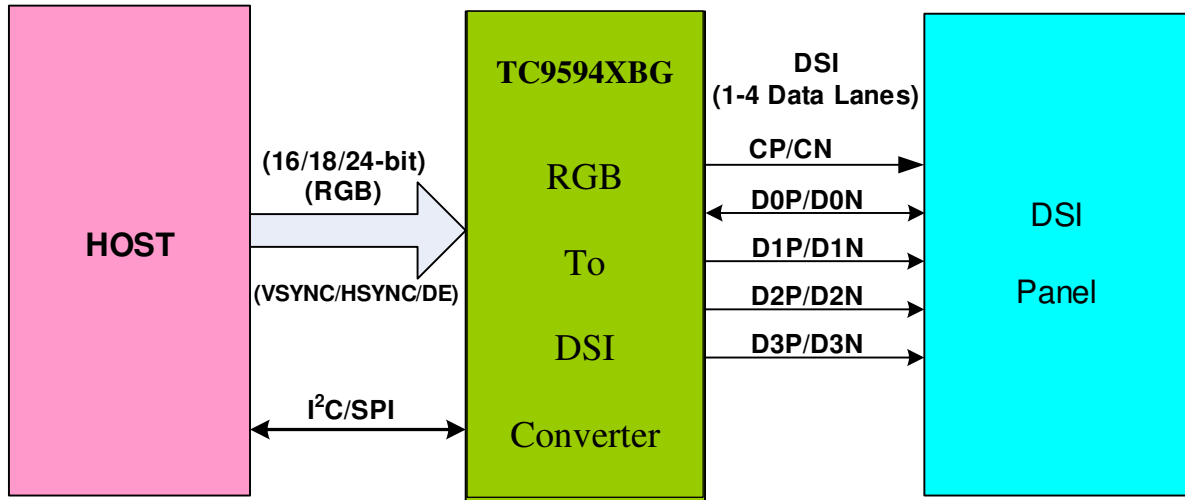

Figure 1.1 System Overview with TC9594XBG in RGB to DSI-TX

2. Features

Below are the main features supported by TC9594XBG.

- DSI-TX interface
 - ◇ MIPI® DSI compliant (Version 1.02.00– June 28, 2010)
 - Support DSI Video Mode data transfer
 - DCS command for panel register access
 - ◇ Supports up to 1 Gbps per data lane
 - ◇ Supports 1,2,3 or 4 data lanes
 - ◇ Supports video data formats
 - RGB888/666/565
- RGB interface
 - ◇ Supports data formats
 - 24-bit data bus
 - RGB888/666/565 data formats
 - ◇ Up to 166 MHz input clock
 - ◇ Support VSYNC/HSYNC polarity option (default LOW)
 - ◇ Support DE polarity option (default High)
- I²C/SPI slave interface (Option to select either I²C or SPI interface)
 - ◇ I²C Interface (when CS=L)
 - Support for normal (100 kHz), fast mode (400 kHz) and Special mode (1 MHz)
 - Configure all TC9594XBG internal registers
 - Writing to DCS registers will trigger DCS Command transmission over DSI
 - ◇ SPI interface (when CS =H)
 - SPI interface support for up to 25 MHz operation.
 - Configure all TC9594XBG internal registers
 - Writing to DCS registers will trigger DCS Command transmission over DSI
- GPIO signals
 - ◇ 2 GPIO signals
 - Two GPIO signals can be configured as SPI signals (SPI_SS and SPI_MISO)
 - Or one GPIO signal can be configured as Interrupt output signal, INT.
- System
 - ◇ Clock and power management support to achieve low power states.
- Power supply inputs
 - ◇ Core and MIPI® D-PHY: 1.2 V
 - ◇ I/O: 1.8 V or 3.3 V
- AEC-Q100 qualified with the following definition
 - ◇ Grade 2 : -40 °C to 105 °C ambient operating temperature range

- Typical Power Consumption

- ✧ WXGA @60fps: Pixel Clk: 74.25 MHz, DSIClk: 312 MHz → 66.6 mW
- ✧ 1080P @60fps: Pixel Clk: 148.5 MHz, DSIClk: 471 MHz → 91.4 mW

	VDDC	VDDIO	VDDMIPI	Total Power	
	1.2 V	3.3 V	1.2 V		
1080P Video	42.8 mA	0.4 mA	32.3 mA		
	51.36 mW	1.32 mW	38.76 mW	91.44	mW
WXGA Video	34.71 mA	0.167 mA	20.36 mA		
	41.652 mW	0.551 mW	24.432 mW	66.64	mW
Power Down w/o PCLK, RefClk	0.074 mA	0.025 mA	0.004 mA		
	0.089 mW	0.0825 mW	0.0048 mW	176.3	μW

- ✧ Power Down Condition is achieved by turning off clock sources: PClk and RefClk.

3. External Pins

3.1. TC9594XBG pinout description

TC9594XBG resides in BGA80 pin packages. The following table gives the signals of TC9594XBG and their function.

Table 3.1 TC9594XBG Functional Signal List

Group	Pin Name	I/O	Type	Function	Note
System: Reset & Clock (4)	RESX	I	Sch	System reset input, active low	-
	REFCLK	I	N	Reference clock input (6MHz - 40MHz)	-
	MSEL	I	N	Mode Select 1'b0: Test mode 1'b1: Normal mode	-
	CS	I	N	Configuration Select - When CS=L, enable I ² C interface - When CS=H, enable SPI interface	-
MIPI-DSI (10)	MIPI_CP	-	PHY	MIPI-DSI clock positive	-
	MIPI_CN	-	PHY	MIPI-DSI clock negative	-
	MIPI_D0P	-	PHY	MIPI-DSI Data 0 positive	-
	MIPI_D0N	-	PHY	MIPI-DSI Data 0 negative	-
	MIPI_D1P	-	PHY	MIPI-DSI Data 1 positive	-
	MIPI_D1N	-	PHY	MIPI-DSI Data 1 negative	-
	MIPI_D2P	-	PHY	MIPI-DSI Data 2 positive	-
	MIPI_D2N	-	PHY	MIPI-DSI Data 2 negative	-
	MIPI_D3P	-	PHY	MIPI-DSI Data 3 positive	-
	MIPI_D3N	-	PHY	MIPI-DSI Data 3 negative	-
I2C IF (2)	I2C_SCL	OD	Sch	I ² C serial clock or SPI_SCLK	4 mA
	I2C_SDA	OD	Sch	I ² C serial data or SPI_MOSI	4 mA
Parallel Port IF (28)	PD[23:0]	I	N	Parallel Port Input Data Note: PD[23:16] can be configure to be GPIO[10:3]	-
	VSYNC	I	N	Parallel port VSYNC signal	-
	HSYNC	I	N	Parallel port HSYNC signal	-
	DE	I	N	Parallel Port DE signal	-
	PCLK	I	N	Parallel Port Clock signal	-
GPIO (2)	GPIO[2:1]	I/O	N	GPIO[2:1] signals - (GPIO[1] option to become SPI_SS or INT signal) - (GPIO[2] option to become SPI_MISO signal)	4 mA
POWER (9)	VDDC (1.2V)	NA	-	VDD for Internal Core (3)	-
	VDDIO (1.8V or 3.3V)	NA	-	VDDIO is for IO power supply (4)	-
	VDD_MIPI (1.2V)	NA	-	VDD for the MIPI (2)	-
GROUND (25)	VSS	NA	-	Ground	-

3.2. TC9594XBG BGA80 Pin Count Summary

Table 3.2 TC9594XBG BGA 80 Pin Count Summary

Group Name	Pin Count	Notes
SYSTEM	4	-
MIPI-DSI	10	-
I2C IF	2	-
GPIO	2	-
Parallel Port IF	28	-
POWER	9	IO, MIPI and Core Power
GROUND	25	-
TOTAL	80	

3.3. TC9594XBG Pin Layout

A1	A2	A3	A4	A5	A6	A7	A8	A9	A10
VSS	PD17	PD19	PD21	PD23	GPIO2	VDDC	I2C_SCL	MSEL	VSS
B1	B2	B3	B4	B5	B6	B7	B8	B9	B10
VDDC	PD16	PD18	PD20	PD22	GPIO1	VSS	I2C_SDA	RESX	VDDIO
C1	C2	C3	C4	C5	C6	C7	C8	C9	C10
PD15	PD14							MIPI_D3P	MIPI_D3N
D1	D2	D3	D4	D5	D6	D7	D8	D9	D10
PD13	PD12		VSS	VSS	VSS	VSS		MIPI_D2P	MIPI_D2N
E1	E2	E3	E4	E5	E6	E7	E8	E9	E10
PD11	PD10		VSS	VSS	VSS	VSS		VSS	VDD_MIPI
F1	F2	F3	F4	F5	F6	F7	F8	F9	F10
PD9	PD8		VSS	VSS	VSS	VSS		MIPI_CP	MIPI_CN
G1	G2	G3	G4	G5	G6	G7	G8	G9	G10
PD7	PD6		VSS	VSS	VSS	VSS		MIPI_D1P	MIPI_D1N
H1	H2	H3	H4	H5	H6	H7	H8	H9	H10
VDDIO	VSS							VSS	VDD_MIPI
J1	J2	J3	J4	J5	J6	J7	J8	J9	J10
PD4	PD2	PD0	VSS	VSS	PCLK	DE	CS	MIPI_D0P	MIPI_D0N
K1	K2	K3	K4	K5	K6	K7	K8	K9	K10
PD5	PD3	PD1	VDDC	VDDIO	REFCLK	VSYNC	HSYNC	VDDIO	VSS

Figure 3.1 TC9594XBG 80-Pin Layout (Top View)

4. Package

4.1. TC9594XBG Package

The package for TC9594XBG is described in the figure below.

P-VFBGA80-0707-0.65-001

"Unit:mm"

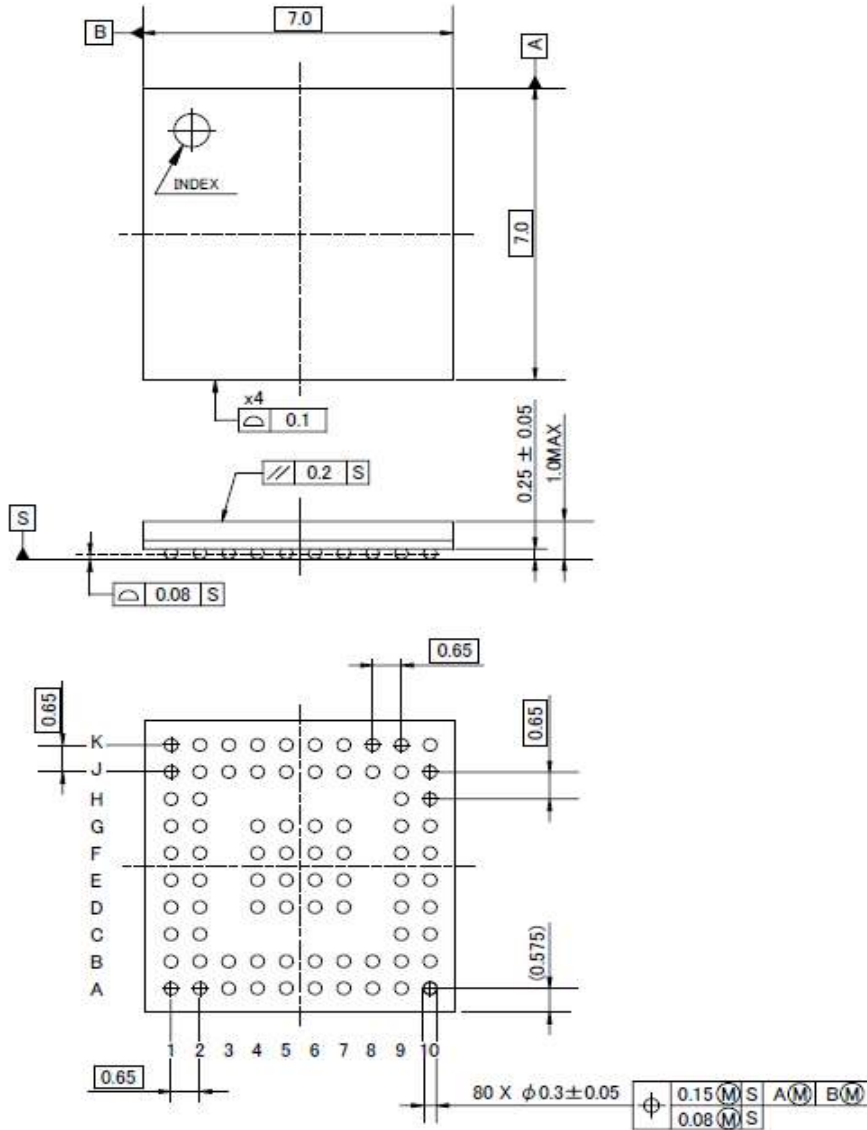

Weight: 66 mg (Typ.)

Figure 4.1 TC9594XBG P-VFBGA80-0707-0.65-001 package

Table 4.1 TC9594XBG P-VFBGA80-0707-0.65-001 Mechanical Dimension

Dimension	Min	Typ.	Max
Solder ball pitch	-	0.65 mm	-
Solder ball height	0.20 mm	0.25 mm	0.30 mm
Package dimension	-	7.0 × 7.0 mm ²	-
Package height	-	-	1.0 mm

5. Electrical Characteristics

5.1. Absolute Maximum Ratings

VSS= 0V reference

Parameter	Symbol	Rating	Unit
Supply voltage (1.8V - Digital IO)	VDDIO	-0.3 to +3.9	V
Supply voltage (1.2V – Digital Core)	VDDC	-0.3 to +1.8	V
Supply voltage (1.2V – MIPI PHY)	VDD_MIPI	-0.3 to +1.8	V
Input voltage (DSI IO)	V _{IN_DSI}	-0.3 to VDD_MIPI+0.3	V
Output voltage (DSI IO)	V _{OUT_DSI}	-0.3 to VDD_MIPI+0.3	V
Input voltage (Digital IO)	V _{IN_IO}	-0.3 to VDDIO+0.3	V
Output voltage (Digital IO)	V _{OUT_IO}	-0.3 to VDDIO+0.3	V
Junction temperature	T _j	125	°C
Storage temperature	T _{stg}	-40 to +125	°C

5.2. Operating Condition

VSS= 0 V reference

Parameter	Symbol	Min	Typ.	Max	Unit
Supply voltage (1.8V – Digital IO)	VDDIO	1.65	1.8	1.95	V
Supply voltage (3.3V – Digital IO)	VDDIO	3.0	3.3	3.6	V
Supply voltage (1.2V – Digital Core)	VDDC	1.1	1.2	1.3	V
Supply voltage (1.2V – MIPI PHY)	VDD_MIPI	1.1	1.2	1.3	V
Operating temperature (ambient temperature with voltage applied)	T _a	-40	+25	+105	°C
Supply Noise Voltage	V _{SN}	-	-	100	mV _{pp}

5.3. DC Electrical Specification

Parameter	Symbol	Min	Typ.	Max	Unit
Input voltage, High level input ^{Note1}	V_{IH}	0.7 VDDIO	-	VDDIO	V
Input voltage, Low level input ^{Note1}	V_{IL}	0	-	0.3 VDDIO	V
Input voltage High level CMOS Schmitt Trigger ^{Note1,2}	V_{IHS}	0.7 VDDIO	-	VDDIO	V
Input voltage Low level CMOS Schmitt Trigger ^{Note1,2}	V_{ILS}	0	-	0.3 VDDIO	V
Output voltage High level ^{Note1, Note2} (Condition: $I_{OH} = -0.4$ mA)	V_{OH}	0.8 VDDIO	-	VDDIO	V
Output voltage Low level ^{Note1, Note2} (Condition: $I_{OL} = 2$ mA)	V_{OL}	0	-	0.2 VDDIO	V
Input leak current, High level (Normal IO or Pull-up IO) (Condition: $V_{IN} = +VDDIO$, VDDIO = 3.6 V)	I_{ILH1} ^{Note3}	-10	-	10	μ A
Input leak current, High level (Pull-down IO) (Condition: $V_{IN} = +VDDIO$, VDDIO = 3.6 V)	I_{ILH2} ^{Note3}	-	-	100	μ A
Input leak current, Low level (Normal IO or Pull-down IO) (Condition: $V_{IN} = 0$ V, VDDIO = 3.6 V)	I_{ILL1} ^{Note4}	-10	-	10	μ A
Input leak current, Low level (Pull-up IO) (Condition: $V_{IN} = 0$ V, VDDIO = 3.6 V)	I_{ILL2} ^{Note4}	-	-	200	μ A

Note 1: Each power source is operating within operation condition.

Note 2: Current output value is specified to each IO buffer individually. Output voltage changes with output current value.

Note 3: Normal pin or Pull-up IO pin applied VDDIO supply voltage to V_{in} (input voltage)

Note 4: Normal pin or Pull-down IO pin applied VSSIO (0V) to V_{in} (input voltage)

6. Revision History

Table 6.1 Revision History

Revision	Date	Description
1.00	2020-04-06	Newly released

RESTRICTIONS ON PRODUCT USE

Toshiba Corporation and its subsidiaries and affiliates are collectively referred to as "TOSHIBA". Hardware, software and systems described in this document are collectively referred to as "Product".

- TOSHIBA reserves the right to make changes to the information in this document and related Product without notice.
- This document and any information herein may not be reproduced without prior written permission from TOSHIBA. Even with TOSHIBA's written permission, reproduction is permissible only if reproduction is without alteration/omission.
- Though TOSHIBA works continually to improve Product's quality and reliability, Product can malfunction or fail. Customers are responsible for complying with safety standards and for providing adequate designs and safeguards for their hardware, software and systems which minimize risk and avoid situations in which a malfunction or failure of Product could cause loss of human life, bodily injury or damage to property, including data loss or corruption. Before customers use the Product, create designs including the Product, or incorporate the Product into their own applications, customers must also refer to and comply with (a) the latest versions of all relevant TOSHIBA information, including without limitation, this document, the specifications, the data sheets and application notes for Product and the precautions and conditions set forth in the "TOSHIBA Semiconductor Reliability Handbook" and (b) the instructions for the application with which the Product will be used with or for. Customers are solely responsible for all aspects of their own product design or applications, including but not limited to (a) determining the appropriateness of the use of this Product in such design or applications; (b) evaluating and determining the applicability of any information contained in this document, or in charts, diagrams, programs, algorithms, sample application circuits, or any other referenced documents; and (c) validating all operating parameters for such designs and applications. **TOSHIBA ASSUMES NO LIABILITY FOR CUSTOMERS' PRODUCT DESIGN OR APPLICATIONS.**
- **PRODUCT IS NEITHER INTENDED NOR WARRANTED FOR USE IN EQUIPMENTS OR SYSTEMS THAT REQUIRE EXTRAORDINARILY HIGH LEVELS OF QUALITY AND/OR RELIABILITY, AND/OR A MALFUNCTION OR FAILURE OF WHICH MAY CAUSE LOSS OF HUMAN LIFE, BODILY INJURY, SERIOUS PROPERTY DAMAGE AND/OR SERIOUS PUBLIC IMPACT ("UNINTENDED USE").** Except for specific applications as expressly stated in this document, Unintended Use includes, without limitation, equipment used in nuclear facilities, equipment used in the aerospace industry, and lifesaving and/or life supporting medical equipment. **IF YOU USE PRODUCT FOR UNINTENDED USE, TOSHIBA ASSUMES NO LIABILITY FOR PRODUCT.** For details, please contact your TOSHIBA sales representative or contact us via our website.
- Do not disassemble, analyze, reverse-engineer, alter, modify, translate or copy Product, whether in whole or in part.
- Product shall not be used for or incorporated into any products or systems whose manufacture, use, or sale is prohibited under any applicable laws or regulations.
- The information contained herein is presented only as guidance for Product use. No responsibility is assumed by TOSHIBA for any infringement of patents or any other intellectual property rights of third parties that may result from the use of Product. No license to any intellectual property right is granted by this document, whether express or implied, by estoppel or otherwise.
- **ABSENT A WRITTEN SIGNED AGREEMENT, EXCEPT AS PROVIDED IN THE RELEVANT TERMS AND CONDITIONS OF SALE FOR PRODUCT, AND TO THE MAXIMUM EXTENT ALLOWABLE BY LAW, TOSHIBA (1) ASSUMES NO LIABILITY WHATSOEVER, INCLUDING WITHOUT LIMITATION, INDIRECT, CONSEQUENTIAL, SPECIAL, OR INCIDENTAL DAMAGES OR LOSS, INCLUDING WITHOUT LIMITATION, LOSS OF PROFITS, LOSS OF OPPORTUNITIES, BUSINESS INTERRUPTION AND LOSS OF DATA, AND (2) DISCLAIMS ANY AND ALL EXPRESS OR IMPLIED WARRANTIES AND CONDITIONS RELATED TO SALE, USE OF PRODUCT, OR INFORMATION, INCLUDING WARRANTIES OR CONDITIONS OF MERCHANTABILITY, FITNESS FOR A PARTICULAR PURPOSE, ACCURACY OF INFORMATION, OR NONINFRINGEMENT.**
- Do not use or otherwise make available Product or related software or technology for any military purposes, including without limitation, for the design, development, use, stockpiling or manufacturing of nuclear, chemical, or biological weapons or missile technology products (mass destruction weapons). Product and related software and technology may be controlled under the applicable export laws and regulations including, without limitation, the Japanese Foreign Exchange and Foreign Trade Law and the U.S. Export Administration Regulations. Export and re-export of Product or related software or technology are strictly prohibited except in compliance with all applicable export laws and regulations.
- Please contact your TOSHIBA sales representative for details as to environmental matters such as the RoHS compatibility of Product. Please use Product in compliance with all applicable laws and regulations that regulate the inclusion or use of controlled substances, including without limitation, the EU RoHS Directive. **TOSHIBA ASSUMES NO LIABILITY FOR DAMAGES OR LOSSES OCCURRING AS A RESULT OF NONCOMPLIANCE WITH APPLICABLE LAWS AND REGULATIONS.**

TOSHIBA ELECTRONIC DEVICES & STORAGE CORPORATION

<https://toshiba.semicon-storage.com/>