

Click to  
**ORDER**  
samples

**AMEOF5-BJZ**

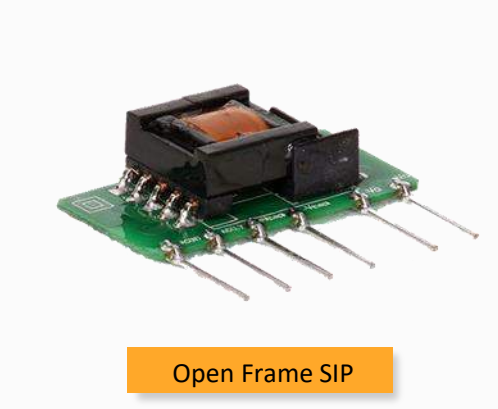

Open Frame SIP

The AMEOF5-BJZ is a compact open frame AC/DC converter that offers an ultra-wide input voltage range of 90-528VAC. This converter is part of Aimtec's wide input voltage range product family offered in 1, 2, 3, 5, 10 & 20 watts.

Aimtec's AMEOF5-BJZ features low power consumption, high efficiency & reliability, and 4000VAC isolation. It also meets the IEC/UL/EN62368 standards, which makes it suitable for many industrial applications such as controls and instrumentation. Furthermore, the ultra-wide input voltage range also makes this converter a perfect candidate for 3 phase applications.

**Features**



- Input: 90-528VAC, 100-745VDC
- I/O Isolation 4000VAC
- Continuous Short circuit protection
- Operating Temp: -40 to +85°C
- Low power consumption ≤ 0.5W at 528VAC
- Compact open frame SIP
- Over current protection
- Class II power supply

**Summary**

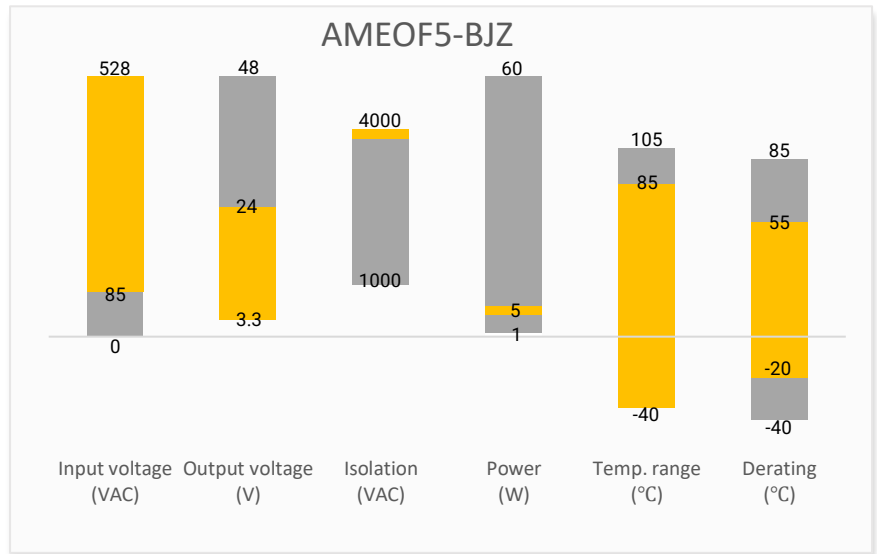

**Training**



Product Training Video  
(click to open)

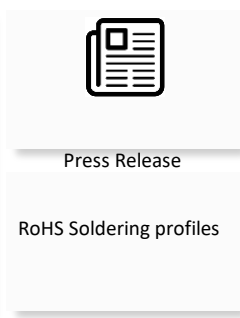

Application Notes

**Applications**



Industrial



Automation



Test Equipment



3-Phase Metering

## Models & Specifications

### Single Output Straight Pins

Model	Input Voltage (VAC/Hz)	Input Voltage (VDC)	Full power temperature range (°C)	Output Voltage (V)	Output Current max (A)	Maximum capacitive Load (230VAC) (μF)	Efficiency 230VAC (%)
AMEOF5-3.3SBJZ	90-528/47-63	100-745	-20 to +55	3.3	850	2200	63
AMEOF5-5SBJZ	90-528/47-63	100-745	-20 to +55	5	850	1500	67
AMEOF5-9SBJZ	90-528/47-63	100-745	-20 to +55	9	560	680	70
AMEOF5-12SBJZ	90-528/47-63	100-745	-20 to +55	12	420	470	76
AMEOF5-15SBJZ	90-528/47-63	100-745	-20 to +55	15	340	330	76
AMEOF5-24SBJZ	90-528/47-63	100-745	-20 to +55	24	210	100	76

### Single Output Bended Pins

Model	Input Voltage (VAC/Hz)	Input Voltage (VDC)	Full power temperature range (°C)	Output Voltage (V)	Output Current max (A)	Maximum capacitive Load (230VAC) (μF)	Efficiency 230VAC (%)
AMEOF5-3.3SLBJZ	90-528/47-63	100-745	-20 to +55	3.3	850	2200	63
AMEOF5-5SLBJZ	90-528/47-63	100-745	-20 to +55	5	850	1500	67
AMEOF5-9SLBJZ	90-528/47-63	100-745	-20 to +55	9	560	680	70
AMEOF5-12SLBJZ	90-528/47-63	100-745	-20 to +55	12	420	470	76
AMEOF5-15SLBJZ	90-528/47-63	100-745	-20 to +55	15	340	330	76
AMEOF5-24SLBJZ	90-528/47-63	100-745	-20 to +55	24	210	100	76

### Input Specification

Parameters	Conditions	Typical	Maximum	Units
Current	115VAC		200	mA
	230VAC		100	mA
	480VAC		70	mA
Inrush current <2ms	115VAC	10		A
	230VAC	17		A
	480VAC	28		A
External fuse	Recommended slow blow type	2		A
Input dissipation	No Load, 230VAC		0.3	W
	No Load, 528VAC		0.5	W
Leakage current	230VAC/50Hz	0.25		mA

### Output Specification

Parameters	Conditions	Typical	Maximum	Units
Voltage accuracy		±2		%
Line regulation	Full load, main input range	±1		%
Load regulation	0-100% load	±1		%
Minimum load	Single output	0		A

Ripple & Noise*	3.3,5,9,12V Output		150	mV p-p
	15,24V Output		250	mV p-p
	36V Output		360	mV p-p
	48V Output		480	mV p-p
Hold-up time	115VAC, 20MHz bandwidth	10		ms
* 20MHz bandwidth with a 0.1uF CC and a 10uF EC				

Isolation Specifications				
Parameters	Conditions	Typical	Rated	Units
Tested I/O voltage	60 sec		4000	VAC
Isolation Resistance		>1000		MΩ

General Specifications				
Parameters	Conditions	Typical	Maximum	Units
Switching frequency		70		KHz
Over current protection	Auto-recovery	120-400		% of I out
Short circuit protection	Hiccup, Continuous			
Short circuit restart	Auto-recovery			
Operating temperature	See derating curve	-40 to +85		°C
Storage temperature		-40 to +105		°C
Temperature coefficient		±0.15		% / °C
Cooling	Free air convection			
Humidity			85	% RH
Weight		7.5		g
Dimensions (L x H x W)	1.75 x 0.94 x 0.51 inches 44.5 x 24.0 x 13.0 mm			
MTBF	>300,000 hours (MIL-HDBK -217F, Ground Benign, t=+25°C)			
NOTE: All specifications in this datasheet are measured at an ambient temperature of 25°C, humidity<75%, nominal input voltage and at rated output load unless otherwise specified.				

Environmental Specifications		
Vibration	Test mode	10-500Hz
	Acceleration	2G, 10min one cycle, every axis tested, 60min total duration

Safety Specifications		
Parameters		
Standards	Information technology Equipment	Design to meet IEC/EN/UL 62368
	EMC - Conducted and radiated emission	CISPR32/EN55032/FCC part 15, Class A & B, with external filter circuits, as referenced
	Electrostatic Discharge Immunity	IEC 61000-4-2, Contact ±4KV, Criteria B
	RF, Electromagnetic Field Immunity	IEC 61000-4-3, 10V/m, Criteria A, with Class B external filter, as referenced
	Electrical Fast Transient/Burst Immunity	IEC 61000-4-4, ±2KV/±4KV, Criteria B, with Class A/B external filter referenced
	Surge Immunity	IEC 61000-4-5, ±1KV/±2KV, Criteria B, with Class A/B external filter referenced
	RF, Conducted Disturbance Immunity	IEC 61000-4-6, 3Vrms, Criteria A, with Class B external filter, as referenced
	Voltage dips, Short Interruptions Immunity	IEC 61000-4-11, 0-70%, Criteria B, with Class B external filter, as referenced

## Dimensions

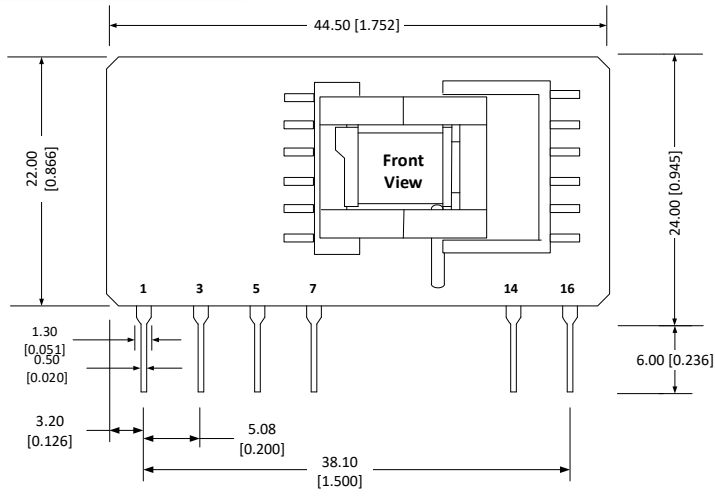

Pin Out Specifications	
Pin	Single
1	AC N
3	AC L
5	+V sc
7	-V sc
14	-V Output
16	+V Output

Note:  
Unit: mm [inch]  
Pin section tolerances:  $\pm 0.10$  [ $\pm 0.004$ ]  
General tolerances:  $\pm 0.50$  [ $\pm 0.020$ ]

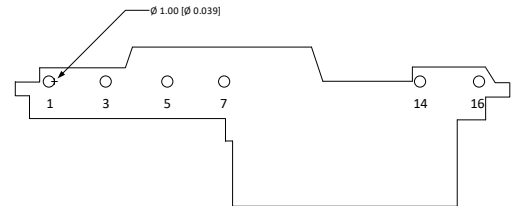
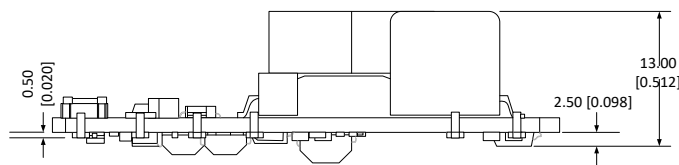

## L Model Dimension

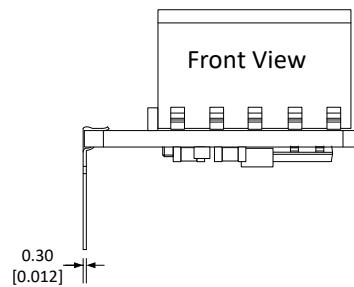
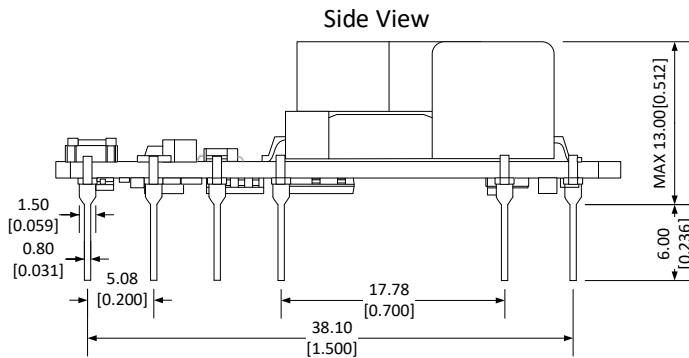
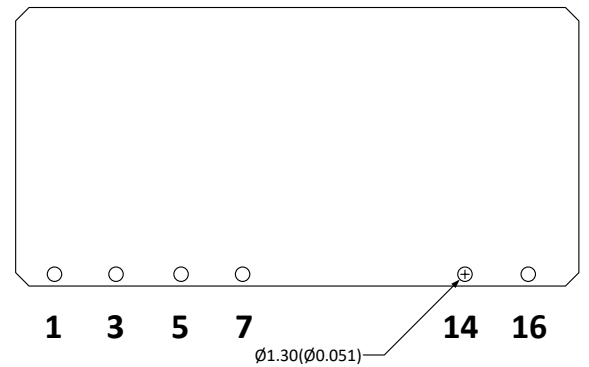
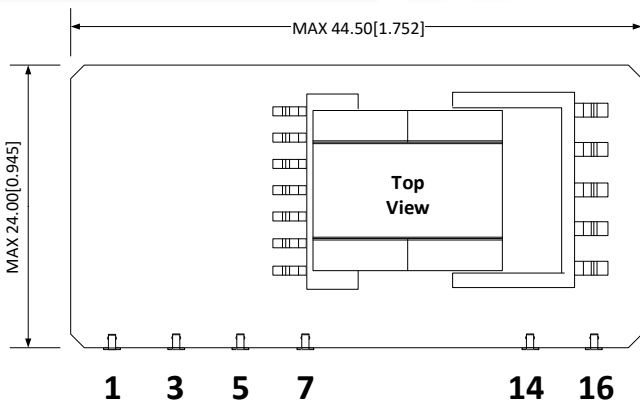

Note:  
Unit: mm [inch]  
Pin section tolerances:  $\pm 0.10$  [ $\pm 0.004$ ]  
General tolerances:  $\pm 0.50$  [ $\pm 0.020$ ]

**Derating**

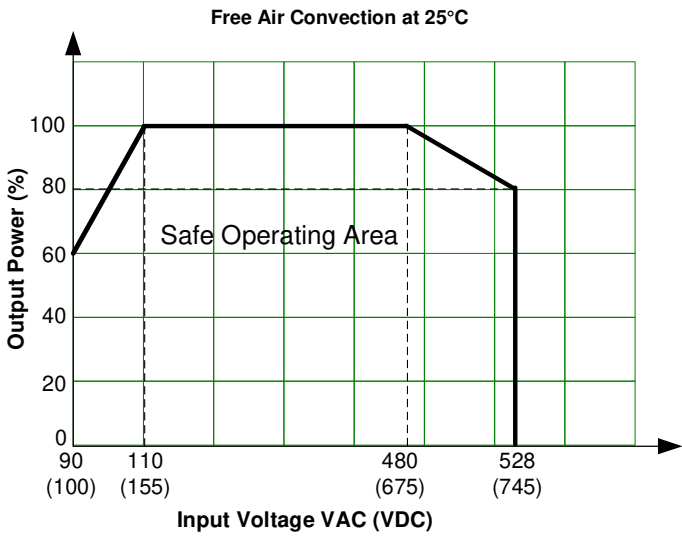
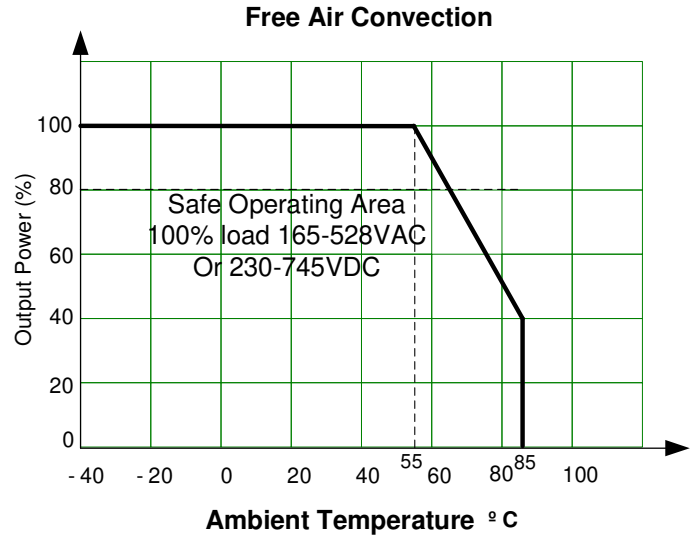
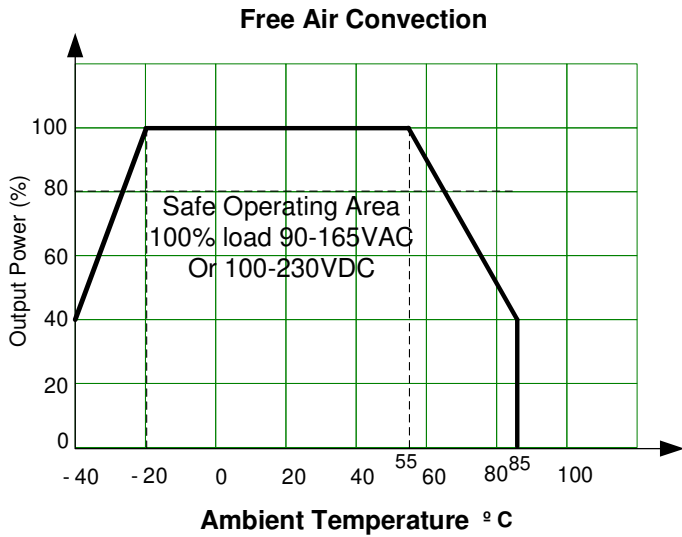

**Typical Application Circuit**

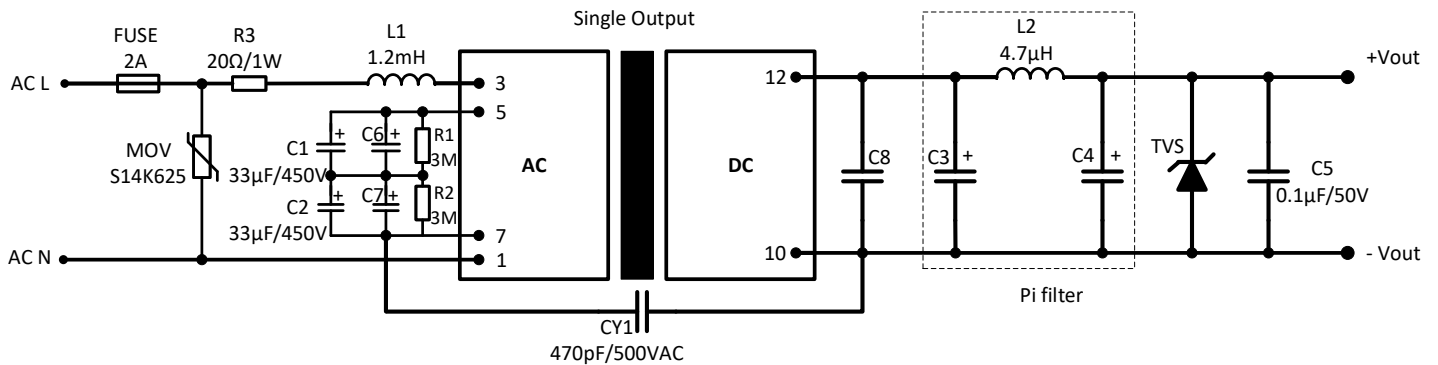

## EMC Recommended Circuit

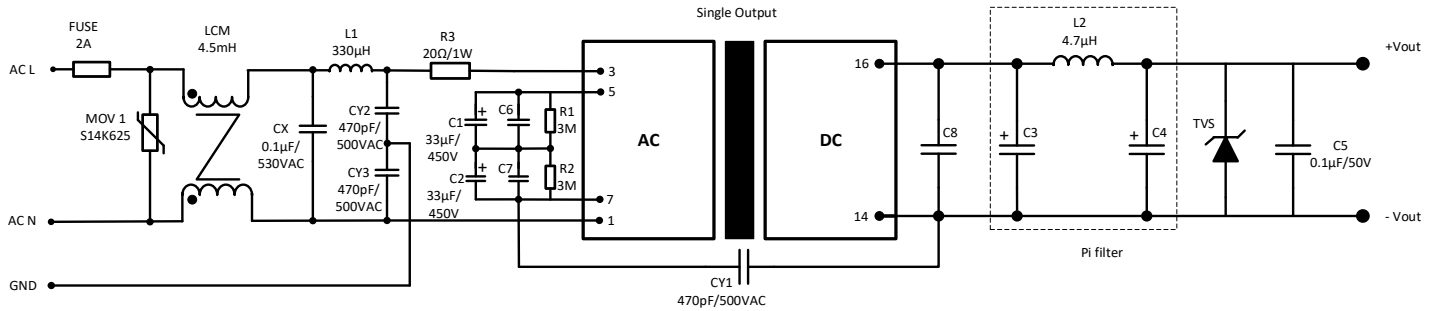

Model	C6/C7	C8	C3	C4	TVS
3.3 Vout	-	-	470µF/16V (Solid Capacitor)	470µF/35V	7V
5 Vout	-	-	470µF/16V (Solid Capacitor)	470µF/35V	7V
9 Vout	-	-	470µF/16V (Solid Capacitor)	470µF/35V	12V
12 Vout	-	-	270µF/16V (Solid Capacitor)	220µF/16V	20V
15 Vout	0.068µF/630V	10uF/25V	1000µF/35V	330µF/35V	20V
24 Vout	-	-	470µF/35V	470µF/35V	30V

- For C1 and C2, use the same brand, model, and batch of electrolytic filter capacitors for the best result.
- For R1 and R2, the maximum operation voltage rating should be at least 450V or higher. It is recommended to connect multiple chip resistors in series to satisfied the voltage rating requirement.
- R3 is for surge current suppression.
- C3, C4, and L2 form a PI filter. It is recommended to use high frequency, high ripple current and low ESR electrolytic capacitors for C3 and C4. The voltage rating for the capacitors and the current rating for L1 and L2 should have at least 20% of margin. Use ceramic capacitors for high-frequency filtering capacitors C5, C6, C7, and C8. In case of a converter failure, A suppressor diode (TVS) is recommended.
- This is an open frame converter, the primary and secondary side external components of the module need at least 10mm safety distance in order to meet the safety requirement.

**NOTE:** 1. Datasheets are updated as needed and as such, specifications are subject to change without notice. Once printed or downloaded, datasheets are no longer controlled by Aimtec; refer to [www.aimtec.com](http://www.aimtec.com) for the most current product specifications. 2. Product labels shown, including safety agency certifications on labels, may vary based on the date manufactured. 3. Mechanical drawings and specifications are for reference only. 4. All specifications are measured at an ambient temperature of 25°C, humidity<75%, nominal input voltage and at rated output load unless otherwise specified. 5. Aimtec may not have conducted destructive testing or chemical analysis on all internal components and chemicals at the time of publishing this document. CAS numbers and other limited information are considered proprietary and may not be available for release. 6. This product is not designed for use in critical life support systems, equipment used in hazardous environments, nuclear control systems or other such applications which necessitate specific safety and regulatory standards other the ones listed in this datasheet. 7. Warranty is in accordance with Aimtec's standard Terms of Sale available at [www.aimtec.com](http://www.aimtec.com).