

PART NUMBER	REVISION	DESCRIPTION	FEED TYPE
2150081-1	D	FINE CRIMP HEIGHT ADJUST	MECHANICAL
2150081-2	E	FINE CRIMP HEIGHT ADJUST	PNEUMATIC
7-2150081-1	D	MECHANICAL AND CRIMP TOOLING KIT	MECHANICAL
7-2150081-2	E	PNEUMATIC AND CRIMP TOOLING KIT	PNEUMATIC
7-2150081-7	B	CRIMP TOOLING KIT	-

ATLANTIC VERSION TERMINATOR INTERFACE ADAPTER

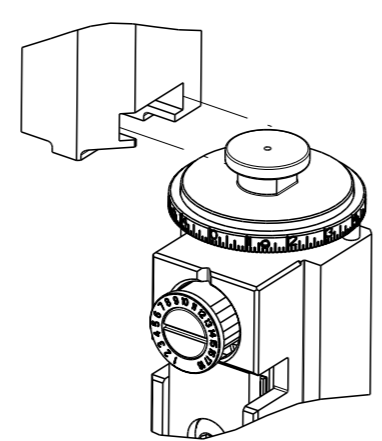

APPLICATOR DATA		
CRIMP	SIZE	TYPE
WIRE	2.29 mm [.090]	F
INSUL	3.30 mm [.130]	F
APPL INSTRUCTIONS 408-35043		

TERMINAL DATA: TE TERMINAL		TE CRIMP SPECIFICATION	
TERMINAL NAME: FASTON CONNECTOR, .187 SERIES REC			
WIRE STRIP LENGTH		INSULATION DIAMETER RANGE	
3.90-4.70 mm [.154-.185 IN]		Ø2.30-3.30 mm [.091-.130 IN]	
TERMINAL APPLICATION SPECIFICATION	114-20081	-	-
TERMINALS APPLIED			
TE TERMINAL	TE TERMINAL	TE TERMINAL	TE TERMINAL
100494-2	5-160433-1	160713-1	281369-2
100651-2	5-160433-6	160713-2	
5-160430-6	6-160433-5	160713-3	
5-160430-7	7-160433-1	160713-4	
6-160430-6	7-160433-8	160713-5	

TERMINAL DATA: TE TERMINAL		TE CRIMP SPECIFICATION	
TERMINAL NAME: FASTON CONNECTOR, .187 SERIES REC			
WIRE STRIP LENGTH		INSULATION DIAMETER RANGE	
3.90-4.70 mm [.154-.185 IN]		Ø2.30-3.30 mm [.091-.130 IN]	
TERMINAL APPLICATION SPECIFICATION	114-20081	-	-
TERMINALS APPLIED			
TE TERMINAL	TE TERMINAL	TE TERMINAL	TE TERMINAL
5-160433-1	5-160430-7	160726-4	160713-1
5-160433-6	6-160430-6	5-160726-2	160713-2
6-160433-5	100651-2	160782-2	160713-3
7-160733-1	100494-2	160782-3	160713-4
7-160733-8	281369-2	160782-5	160713-5
5-160430-6	160726-1		

WIRE SIZE	CRIMP HEIGHT mm [INCH]	CRIMP HEIGHT REFERENCE SETTING
1.50mm2	1.50+/-0.05 [.059+/- .002]	2.0
1.00mm2	1.45+/-0.05 [.057+/- .002]	2.5
0.75mm2	1.40+/-0.05 [.055+/- .002]	3.0
0.50mm2	1.35+/-0.05 [.053+/- .002]	3.5

WIRE SIZE	CRIMP HEIGHT mm [INCH]	CRIMP HEIGHT REFERENCE SETTING
1.50mm2	1.56+/-0.05 [.061+/- .002]	1.5
1.00mm2	1.39+/-0.05 [.055+/- .002]	3.0
0.75mm2	1.31+/-0.05 [.052+/- .002]	3.8
0.50mm2	1.22+/-0.05 [.048+/- .002]	4.8

TERMINAL DATA: TE TERMINAL		TE CRIMP SPECIFICATION	
TERMINAL NAME: FASTON CONNECTOR, .187 SERIES REC			
WIRE STRIP LENGTH		INSULATION DIAMETER RANGE	
3.90-4.70 mm [.154-.185 IN]		Ø2.30-3.30 mm [.091-.130 IN]	
TERMINAL APPLICATION SPECIFICATION	114-20081	-	-
TERMINALS APPLIED			
TE TERMINAL	TE TERMINAL	TE TERMINAL	TE TERMINAL
100494-2			

WIRE SIZE	CRIMP HEIGHT mm [INCH]	CRIMP HEIGHT REFERENCE SETTING
1.50mm2	1.50+/-0.05 [.059+/- .002]	2.0
1.40mm2	1.47+/-0.05 [.058+/- .002]	2.3
1.00mm2	1.45+/-0.05 [.057+/- .002]	2.5
0.75mm2	1.40+/-0.05 [.055+/- .002]	3.0
0.50mm2	1.35+/-0.05 [.053+/- .002]	3.5

TERMINAL DATA: TE TERMINAL		TE CRIMP SPECIFICATION	
TERMINAL NAME: FASTON CONNECTOR, .187 SERIES REC			
WIRE STRIP LENGTH		INSULATION DIAMETER RANGE	
6.03-7.03 mm [.237-.277 IN]		Ø2.30-3.30 mm [.091-.130 IN]	
TERMINAL APPLICATION SPECIFICATION	114-106242	-	-
TERMINALS APPLIED			
TE TERMINAL	TE TERMINAL	TE TERMINAL	TE TERMINAL
2293255-1			

WIRE SIZE	CRIMP HEIGHT mm [INCH]	CRIMP HEIGHT REFERENCE SETTING
1.50mm2	1.47+/-0.05 [.058+/- .002]	2.3
1.00mm2	1.31+/-0.05 [.052+/- .002]	3.8
0.75mm2	1.22+/-0.05 [.048+/- .002]	4.8
0.50mm2	1.11+/-0.05 [.044+/- .002]	5.9

LOC	DIST	REVISIONS					
A	66	P	LYR	DESCRIPTION	DATE	OWN	APVD
		B3		ECR-17-000976	26JAN2017	KH	JDG
		C		ECR-17-011615	09AUG2017	TB	TE
		D		ECR-18-015451	27SEP2018	TB	TE
		E		ECR-19-009578	20JUN2019	LG	TE

-	1	-	1	-	2119641-1	FEED CAM, AIR FEED	248	
-	1	1	1	1	2119082-9	CAM, SNAIL, INSULATION ADJUSTMENT	244	
-	1	1	1	1	2079764-1	WASHER, WAVE SPRING, CREST-TO-CREST	243	
-	1	1	1	1	2119083-1	RETAINER, INSULATION DIAL	242	
-	-	1	-	1	2119580-1	MECHANICAL FEED ASSEMBLY	239	
-	1	-	1	-	2844940-3	AIR FEED MODULE	238	
-	1	1	1	1	1-18028-0	WASHER, FLAT, REG M8	192	
-	1	1	1	1	1752354-4	STANDOFF, HOLD-DOWN	180	
-	1	1	1	1	6-993111-6	PIN, SLOTTED SPRING 3.0 X 14.0	177	
-	1	1	1	1	8-22280-7	SPRING, COMPRESSION	176	
-	1	1	1	1	1752353-2	GUIDE PIN, HOLDDOWN	175	
-	1	1	1	1	1901680-2	GUIDE PIN, HOLDDOWN	174	
-	REF	REF	REF	REF	994970-2	COUNTER, MAGNETIC	164	
-	1	1	1	1	455888-7	SPACER, CRIMPER	82	
-	1	1	1	1	1803607-4	DOCUMENTATION PACKAGE	71	
-	2	2	2	2	2-18032-2	SCR, SET, FLT PNT, M3 X 10.0	70	
-	1	1	1	1	2119740-1	TAG, IDENTIFICATION	67	
-	2	2	2	2	2168078-1	SCREW, DRIVE, RH, RoHS, 2 x .188	66	
-	1	1	1	1	1-1901681-8	HOLDDOWN, TERMINAL	65	
-	1	1	1	1	2168083-2	SCR, SKT HD CAP, RoHS, M4 X 8.0	60	
-	1	1	1	1	5-18022-5	SCR, HEX HD CAP, M4 X 6.0	59	
-	-	1	-	1	2063961-1	FEED FINGER	58	
-	4	4	4	4	2168400-4	SHCS, LOW HEAD, RoHS, M4 X 8	57	
-	2	2	2	2	2168083-2	SCR, SKT HD CAP, RoHS, M4 X 8.0	56	
-	2	2	2	2	5018030-1	NUT, HEX, REG, RoHS, M3	54	
-	2	2	2	2	986965-8	NUT, LOCK, HEX, TORQUE (M4)	53	
-	1	1	1	1	1-5018030-0	NUT, HEX, REG, RoHS, M3.5	52	
-	1	-	1	-	2063961-1	FEED FINGER	51	
-	1	2	1	2	18023-9	SCR, SKT HD CAP M4 X 6.0	49	
-	-	1	-	1	2119652-1	FEED CAM, PRE FEED	48	
-	-	1	-	1	2119653-1	FEED CAM, POST FEED	47	
-	1	1	1	1	2119655-5	APPLICATOR BASIC ASSEMBLY, EF	46	
-	1	1	1	1	1803517-1	RAM ASSEMBLY, EF ATLANTIC	44	
-	1	1	1	1	1803602-1	SCR, BHSC, RoHS (M8 X 25)	41	
-	8	8	8	8	1-18028-2	WASHER, FLAT, REG M4	33	
-	2	2	2	2	2168083-9	SCR, SKT HD CAP, RoHS, M4 X 20	31	
-	2	2	2	2	2168083-2	SCR, SKT HD CAP, RoHS, M4 X 8.0	29	
-	1	1	1	1	240639-4	STRIPPER (MACHINING)	27	
-	2	2	2	2	1-2168083-5	SCR, SKT HD CAP, RoHS, M4 X 30	25	
-	1	1	1	1	1752371-1	PLATE, STRIP GUIDE	24	
-	2	2	2	2	2-22281-3	SPRING, COMPRESSION	22	
-	1	1	1	1	1803292-4	DRAG	20	
-	1	1	1	1	1803152-1	STRIP GUIDE, REAR	19	
-	1	1	1	1	1803151-1	STRIP GUIDE, FRONT	18	
-	4	4	4	4	1-2079383-1	SCR, BHSC, RoHS (M6 X 12)	17	
-	1	1	1	1	1-240641-7	SPACER	16	
-	1	1	1	1	240644-1	PLATE, REAR SHEAR	11	
-	-	-	-	-	-	-	10	
-	1	1	1	1	1-690495-4	PLATE, FRONT SHEAR	9	
-	1	2	2	1	1333217-4	ANVIL, EF .090	8	
-	1	1	1	1	2217206-7	BLADE, SLUG	7	
-	1	1	1	1	240641-6	SPACER	5	
-	1	1	1	1	238011-2	BLOCK, CRIMPER SPACER	4	
-	1	2	2	1	2-1633961-6	CRIMPER, INSULATION F PREMIUM	3	
-	1	1	1	1	455888-8	SPACER, CRIMPER	2	
-	1	2	2	1	2-456406-3	CRIMPER, WIRE PREMIUM	1	
-	77	72	71	2	-1	PART NO	DESCRIPTION	ITEM NO

- 1 RECOMMENDED SPARE PARTS
- 2 REFER TO SUPPLIED INSTRUCTION SHEET FOR CLEANING, LUBRICATION AND STORAGE OF APPLICATOR.
- 3 APPLY PART NUMBER 2-23419-6 LOCTITE TO THREADS OF ITEM 242. APPLY PART NUMBER 1-23419-5 LOCTITE TO THREADS OF ITEM 180.
- 4 CRIMP HEIGHT REFERENCE SETTING WAS THE SETTING USED WHEN THE APPLICATOR WAS QUALIFIED AT THE FACTORY. ADJUSTMENT MAY BE NECESSARY WHEN RUNNING APPLICATOR IN THE FIELD.
- 5 THESE ARE ALTERNATE CRIMP HEIGHT VALUES. REFER TO TERMINAL APPLICATION SPECIFICATION FOR DETAILS.
- 6. UNLESS SPECIFIED OTHERWISE TORQUE VALUES SHALL BE USED PER DOCUMENT, 101-35000.

***WARNING**
ON INSTALLATION, SET WIRE DISC TO CRIMP HEIGHT REFERENCE SETTING FOR LARGEST WIRE SIZE. CRIMP HEIGHT REFERENCE SETTINGS GREATER THAN THE VALUE SHOWN MAY CAUSE DAMAGE TO THE CRIMP TOOLING. REFER TO THE INSTRUCTION SHEET FOR PROPER SETUP AND ADJUSTMENTS.

ATLANTIC VERSION
Shown on sheets 1 of 4 & 2 of 4
(Pacific version shown on sheets 3 of 4 & 4 of 4)

DIMENSIONS:		TOLERANCES UNLESS OTHERWISE SPECIFIED:		MATERIAL:	
mm	0 PLC ±	1 PLC ±	2 PLC ±	3 PLC ±	4 PLC ±
	ANGLES	FINISH			
WEIGHT		SCALE		SHEET	
CUSTOMER ACCESSIBLE PRODUCTION DRAWING		SCALE 1:1		SHEET 1 OF 4	

LOC	DIST	REV	DESCRIPTION	DATE	OWN	APVD
A	66		SEE SHEET 1			

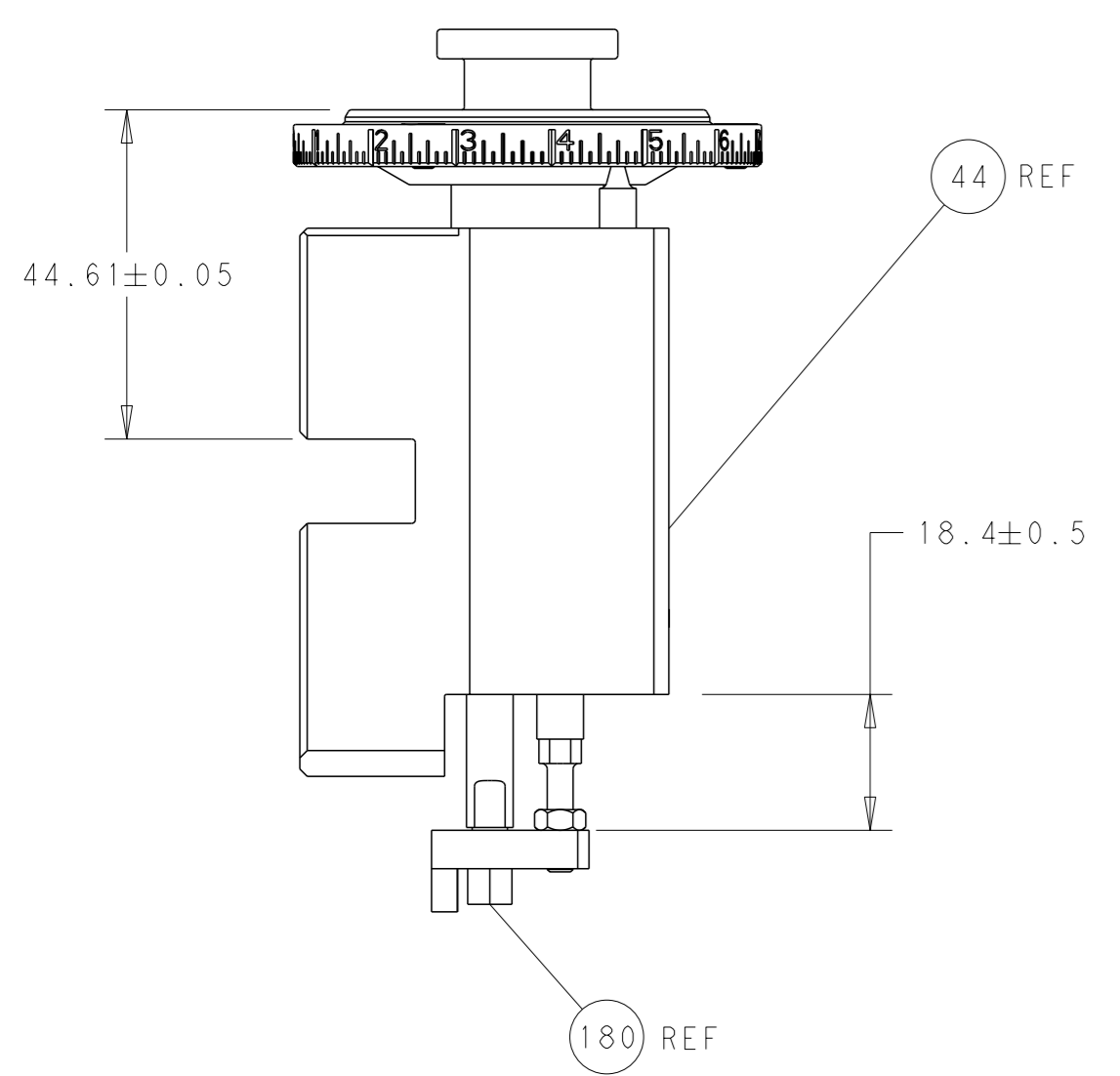

RAM AND HOLDDOWN SET-UP

FEED TYPE
MECHANICAL

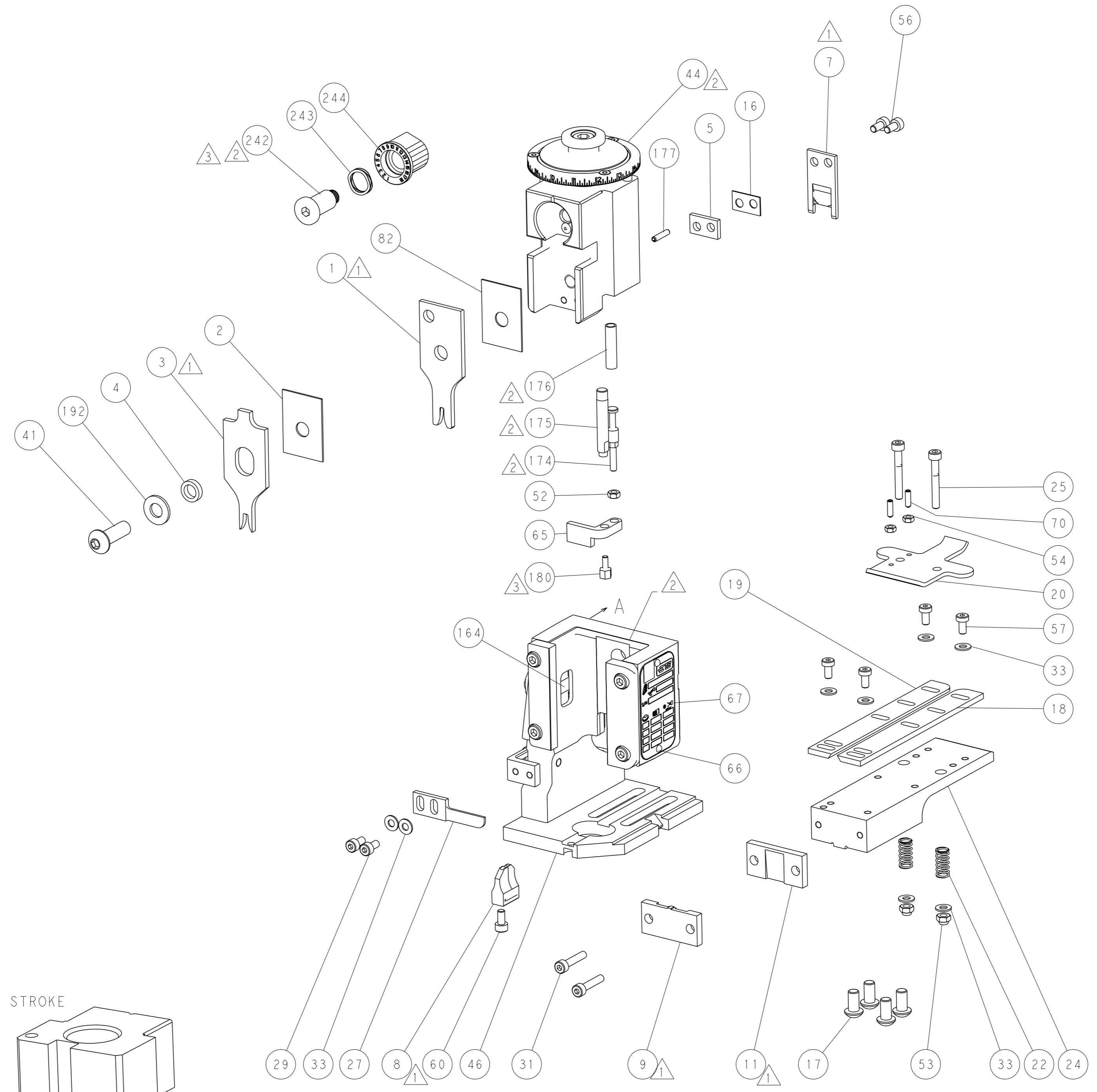
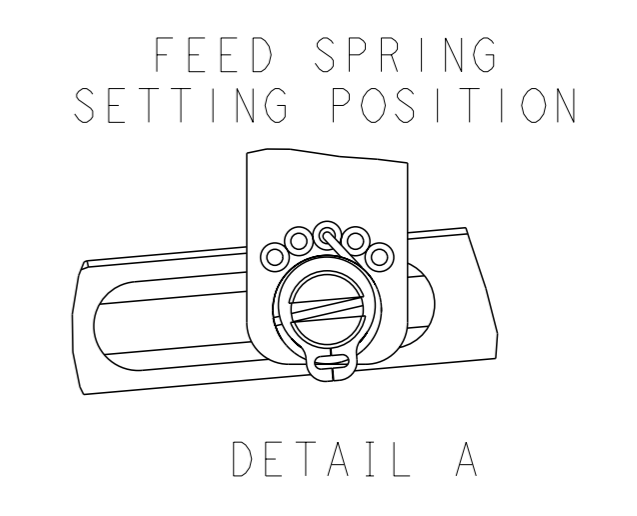
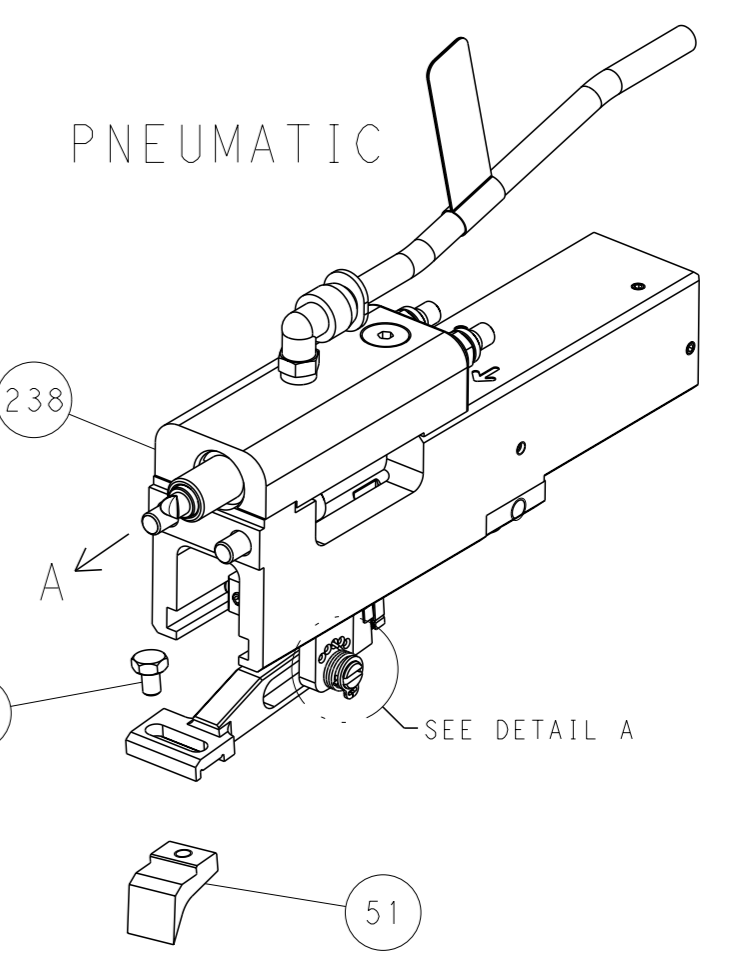
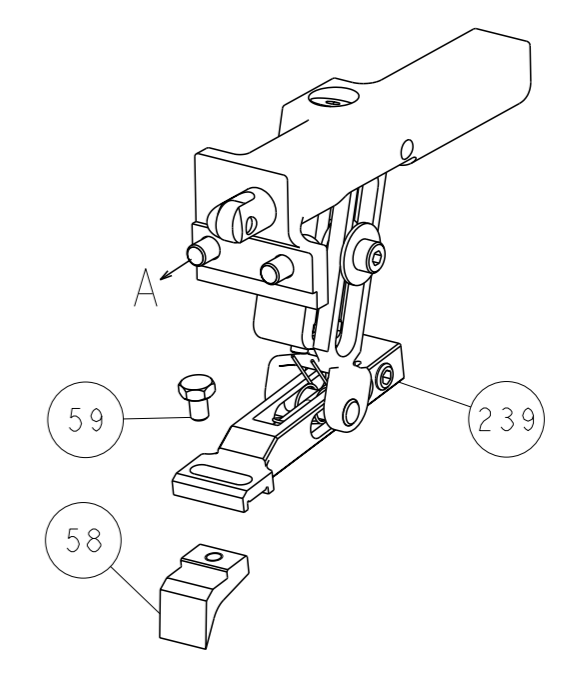

CAM POSITIONS

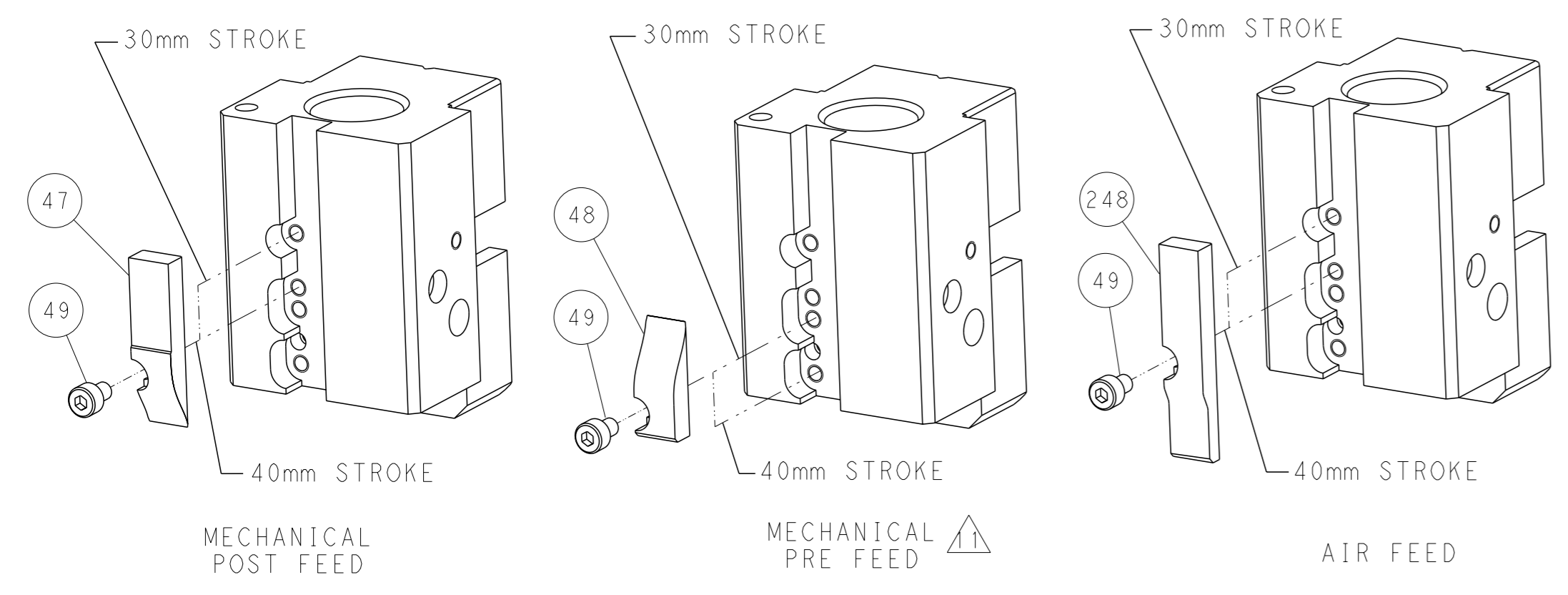

ATLANTIC VERSION
 Shown on sheets 1 of 4 & 2 of 4
 (Pacific version shown on sheets 3 of 4 & 4 of 4)

<small>THIS DRAWING IS A CONTROLLED DOCUMENT FROM TYCO ELECTRONICS CORPORATION. IT IS SUBJECT TO CHANGE AND THE CONTROLLER'S RESERVATION. DISSEMINATION SHOULD BE LIMITED TO THE INTENTED RECIPIENT.</small>		OWN: L. ZHANG 07FEB2012 CHK: L. ZHANG 07FEB2012 APVD: S. XI 07FEB2012	TE Connectivity Harrisburg, PA 17105-3608
DIMENSIONS: mm TOLERANCES UNLESS OTHERWISE SPECIFIED: 0 PLC ± 1 PLC ± 2 PLC ± 3 PLC ± 4 PLC ± ANGLES FINISH ±		NAME: Ocean End Feed Applicator SIZE: A1 CAGE CODE: 00779 DRAWING NO: C=2150081	RESTRICTED TO: E
MATERIAL:		WEIGHT:	CUSTOMER ACCESSIBLE PRODUCTION DRAWING SCALE: 1:1 SHEET: 2 of 4 REV: E

PART NUMBER	REVISION	DESCRIPTION	FEED TYPE
2-2150081-1	D	FINE CRIMP HEIGHT ADJUST	MECHANICAL
2-2150081-2	E	FINE CRIMP HEIGHT ADJUST	PNEUMATIC
7-2150081-7	B	CRIMP TOOLING KIT	-

PACIFIC VERSION TERMINATOR
INTERFACE ADAPTER

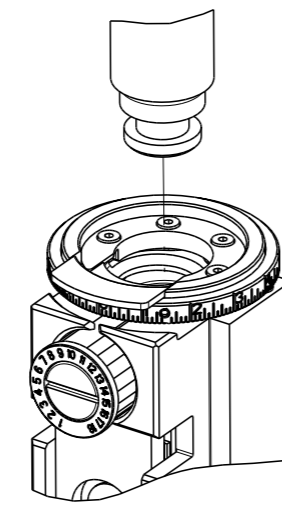

APPLICATOR DATA		
CRIMP	SIZE	TYPE
WIRE	2.29 mm [.090]	F
INSUL	3.30 mm [.130]	F
APPL INSTRUCTIONS 408-35043		

TERMINAL DATA: TE TERMINAL		TE CRIMP SPECIFICATION	
TERMINAL NAME: FASTON CONNECTOR, .187 SERIES REC			
WIRE STRIP LENGTH		INSULATION DIAMETER RANGE	
3.90-4.70 mm [.154-.185 IN]		Ø2.30-3.30 mm [.091-.130 IN]	
TERMINAL APPLICATION SPECIFICATION	114-20081	-	-
TERMINALS APPLIED			
TE TERMINAL	TE TERMINAL	TE TERMINAL	TE TERMINAL
100494-2	5-160433-1	160713-1	281369-2
100651-2	5-160433-6	160713-2	
5-160430-6	6-160433-5	160713-3	
5-160430-7	7-160433-1	160713-4	
6-160430-6	7-160433-8	160713-5	

WIRE SIZE	CRIMP HEIGHT mm [INCH]	CRIMP HEIGHT REFERENCE SETTING
1.50mm2	1.50+/-0.05 [.059+/- .002]	2.0
1.00mm2	1.45+/-0.05 [.057+/- .002]	2.5
0.75mm2	1.40+/-0.05 [.055+/- .002]	3.0
0.50mm2	1.35+/-0.05 [.053+/- .002]	3.5

TERMINAL DATA: TE TERMINAL		TE CRIMP SPECIFICATION	
TERMINAL NAME: FASTON CONNECTOR, .187 SERIES REC			
WIRE STRIP LENGTH		INSULATION DIAMETER RANGE	
3.90-4.70 mm [.154-.185 IN]		Ø2.30-3.30 mm [.091-.130 IN]	
TERMINAL APPLICATION SPECIFICATION	114-20081	-	-
TERMINALS APPLIED			
TE TERMINAL	TE TERMINAL	TE TERMINAL	TE TERMINAL
5-160433-1	5-160430-7	160726-4	160713-1
5-160433-6	6-160430-6	5-160726-2	160713-2
6-160433-5	100651-2	160782-2	160713-3
7-160733-1	100494-2	160782-3	160713-4
7-160733-8	281369-2	160782-5	160713-5
5-160430-6	160726-1		

WIRE SIZE	CRIMP HEIGHT mm [INCH]	CRIMP HEIGHT REFERENCE SETTING
1.50mm2	1.56+/-0.05 [.061+/- .002]	1.5
1.00mm2	1.39+/-0.05 [.055+/- .002]	3.0
0.75mm2	1.31+/-0.05 [.052+/- .002]	3.8
0.50mm2	1.22+/-0.05 [.048+/- .002]	4.8

TERMINAL DATA: TE TERMINAL		TE CRIMP SPECIFICATION	
TERMINAL NAME: FASTON CONNECTOR, .187 SERIES REC			
WIRE STRIP LENGTH		INSULATION DIAMETER RANGE	
3.90-4.70 mm [.154-.185 IN]		Ø2.30-3.30 mm [.091-.130 IN]	
TERMINAL APPLICATION SPECIFICATION	114-20081	-	-
TERMINALS APPLIED			
TE TERMINAL	TE TERMINAL	TE TERMINAL	TE TERMINAL
100494-2			

WIRE SIZE	CRIMP HEIGHT mm [INCH]	CRIMP HEIGHT REFERENCE SETTING
1.50mm2	1.50+/-0.05 [.059+/- .002]	2.0
1.40mm2	1.47+/-0.05 [.058+/- .002]	2.3
1.00mm2	1.45+/-0.05 [.057+/- .002]	2.5
0.75mm2	1.40+/-0.05 [.055+/- .002]	3.0
0.50mm2	1.35+/-0.05 [.053+/- .002]	3.5

TERMINAL DATA: TE TERMINAL		TE CRIMP SPECIFICATION	
TERMINAL NAME: FASTON CONNECTOR, .187 SERIES REC			
WIRE STRIP LENGTH		INSULATION DIAMETER RANGE	
6.03-7.03 mm [.237-.277 IN]		Ø2.30-3.30 mm [.091-.130 IN]	
TERMINAL APPLICATION SPECIFICATION	114-106242	-	-
TERMINALS APPLIED			
TE TERMINAL	TE TERMINAL	TE TERMINAL	TE TERMINAL
2293255-1			

WIRE SIZE	CRIMP HEIGHT mm [INCH]	CRIMP HEIGHT REFERENCE SETTING
1.50mm2	1.47+/-0.05 [.058+/- .002]	2.3
1.00mm2	1.31+/-0.05 [.052+/- .002]	3.8
0.75mm2	1.22+/-0.05 [.048+/- .002]	4.8
0.50mm2	1.11+/-0.05 [.044+/- .002]	5.9

LOC	DIST	REVISIONS					
A	66	P	LYR	DESCRIPTION	DATE	OWN	APPV
		-	-	SEE SHEET 1	-	-	-

-	1	1	2119082-9	CAM, SNAIL, INSULATION ADJUSTMENT	244
-	1	1	2079764-1	WASHER, WAVE SPRING, CREST-TO-CREST	243
-	1	1	2119083-1	RETAINER, INSULATION DIAL	242
-	-	1	2119580-1	MECHANICAL FEED ASSEMBLY	239
-	1	-	2844940-3	AIR FEED MODULE	238
-	1	1	1-18028-0	WASHER, FLAT, REG M8	192
-	4	4	2079383-9	SCR, BHSC, RoHS (M6 X 20)	186
-	1	1	1752354-4	STANDOFF, HOLD-DOWN	180
-	1	1	6-993111-6	PIN, SLOTTED SPRING 3.0 X 14.0	177
-	1	1	8-22280-7	SPRING, COMPRESSION	176
-	1	1	1752353-2	GUIDE PIN, HOLDDOWN	175
-	1	1	1901680-2	GUIDE PIN, HOLDDOWN	174
-	REF	REF	994970-2	COUNTER, MAGNETIC	164
-	1	-	2119641-2	FEED CAM, AIR FEED	152
-	1	1	2168083-8	SCR, SKT HD CAP, RoHS, M4 X 16	144
-	-	1	2119653-2	FEED CAM, POST FEED	142
-	-	1	2119655-6	APPLICATOR BASIC ASSEMBLY, EF	141
-	1	1	1803518-1	RAM ASSEMBLY, EF PACIFIC	140
-	1	1	455888-7	SPACER, CRIMPER	82
-	1	1	1803607-4	DOCUMENTATION PACKAGE	71
-	2	2	2-18032-2	SCR, SET, FLT PNT, M3 X 10.0	70
-	1	1	2119740-1	TAG, IDENTIFICATION	67
-	2	2	2168078-1	SCREW, DRIVE, RH, RoHS, 2 x .188	66
-	1	1	1-1901681-8	HOLDDOWN, TERMINAL	65
-	1	1	5-18022-5	SCR, HEX HD CAP, M4 X 6.0	59
-	-	1	2063961-1	FEED FINGER	58
-	4	4	2168400-4	SHCS, LOW HEAD, RoHS, M4 X 8	57
-	2	2	2168083-2	SCR, SKT HD CAP, RoHS, M4 X 8.0	56
-	2	2	5018030-1	NUT, HEX, REG, RoHS, M3	54
-	2	2	986965-8	NUT, LOCK, HEX, TORQUE (M4)	53
-	1	1	1-5018030-0	NUT, HEX, REG, RoHS, M3.5	52
-	1	-	2063961-1	FEED FINGER	51
-	1	2	18023-9	SCR, SKT HD CAP M4 X 6.0	49
-	-	1	2119652-1	FEED CAM, PRE FEED	48
-	1	1	1803602-1	SCR, BHSC, RoHS (M8 X 25)	41
-	8	8	1-18028-2	WASHER, FLAT, REG M4	33
-	2	2	2168083-9	SCR, SKT HD CAP, RoHS, M4 X 20	31
-	2	2	2168083-2	SCR, SKT HD CAP, RoHS, M4 X 8.0	29
-	1	1	240639-4	STRIPPER (MACHINING)	27
-	2	2	1-2168083-5	SCR, SKT HD CAP, RoHS, M4 X 30	25
-	1	1	1752371-1	PLATE, STRIP GUIDE	24
-	2	2	2-22281-3	SPRING, COMPRESSION	22
-	1	1	1803292-4	DRAG	20
-	1	1	1803152-1	STRIP GUIDE, REAR	19
-	1	1	1803151-1	STRIP GUIDE, FRONT	18
-	1	1	1-240641-7	SPACER	16
-	1	1	240644-1	PLATE, REAR SHEAR	11
-	-	-	-	-	10
-	1	1	1-690495-4	PLATE, FRONT SHEAR	9
1	1	1	1333217-4	ANVIL, EF .090	8
1	1	1	2217206-7	BLADE, SLUG	7
-	1	1	240641-6	SPACER	5
-	1	1	238011-2	BLOCK, CRIMPER SPACER	4
1	1	1	2-1633961-6	CRIMPER, INSULATION F PREMIUM	3
-	1	1	455888-8	SPACER, CRIMPER	2
1	1	1	2-456406-3	CRIMPER, WIRE PREMIUM	1

- RECOMMENDED SPARE PARTS
- REFER TO SUPPLIED INSTRUCTION SHEET FOR CLEANING, LUBRICATION AND STORAGE OF APPLICATOR.
- APPLY PART NUMBER 2-23419-6 LOCTITE TO THREADS OF ITEM 242. APPLY PART NUMBER 1-23419-5 LOCTITE TO THREADS OF ITEM 180.
- CRIMP HEIGHT REFERENCE SETTING WAS THE SETTING USED WHEN THE APPLICATOR WAS QUALIFIED AT THE FACTORY. ADJUSTMENT MAY BE NECESSARY WHEN RUNNING APPLICATOR IN THE FIELD.
- THESE ARE ALTERNATE CRIMP HEIGHT VALUES. REFER TO TERMINAL APPLICATION SPECIFICATION FOR DETAILS.
- 6. UNLESS SPECIFIED OTHERWISE TORQUE VALUES SHALL BE USED PER DOCUMENT, 101-35000.

***WARNING**
ON INSTALLATION, SET WIRE DISC TO CRIMP HEIGHT REFERENCE SETTING FOR LARGEST WIRE SIZE. CRIMP HEIGHT REFERENCE SETTINGS GREATER THAN THE VALUE SHOWN MAY CAUSE DAMAGE TO THE CRIMP TOOLING. REFER TO THE INSTRUCTION SHEET FOR PROPER SETUP AND ADJUSTMENTS.

PACIFIC VERSION
Shown on sheets 3 of 4 & 4 of 4
(Atlantic version shown on sheets 1 of 4 & 2 of 4)

DIMENSIONS:		TOLERANCES UNLESS OTHERWISE SPECIFIED:		DRAWING NO	
mm	0 PLC ±	1 PLC ±	2 PLC ±	3 PLC ±	4 PLC ±
	ANGLES	FINISH		WEIGHT	SCALE
MATERIAL					

LOC	DIST	REV	DESCRIPTION	DATE	OWN	APVD
A	66		SEE SHEET 1			

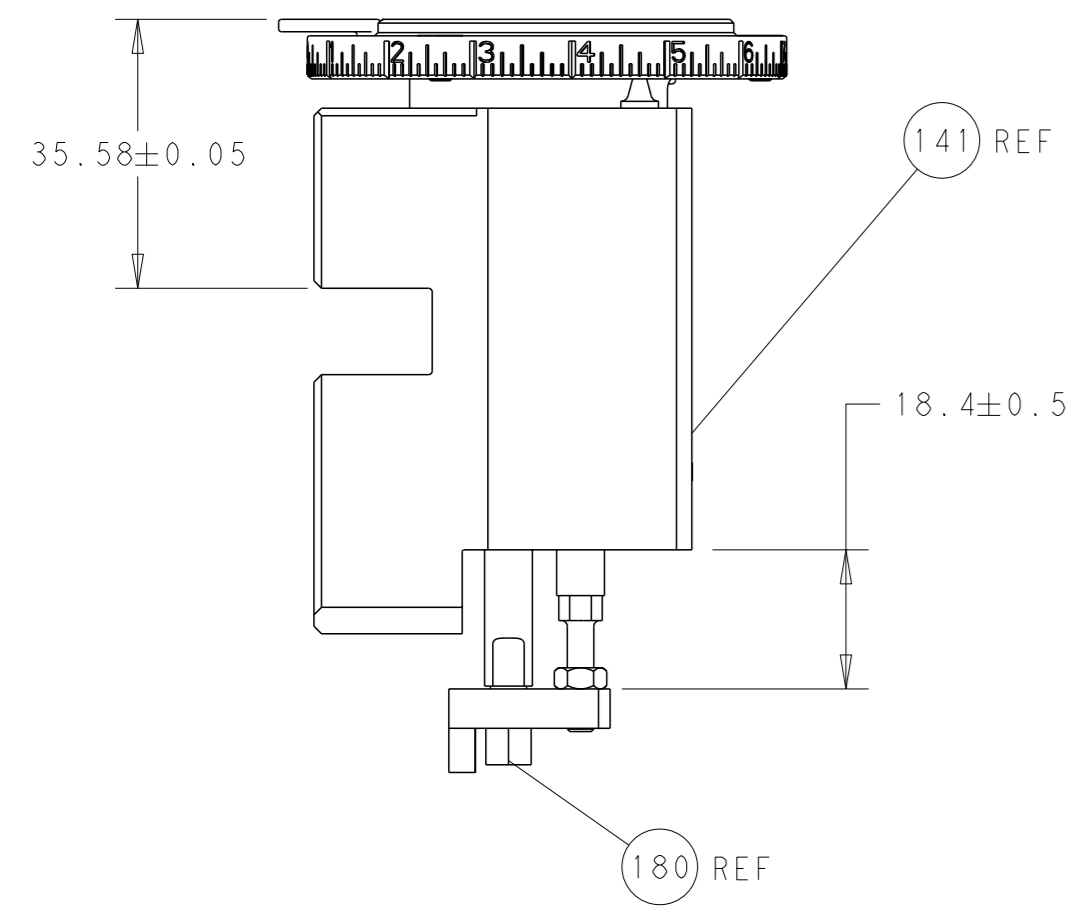

RAM AND HOLDDOWN SET-UP

FEED TYPE
MECHANICAL

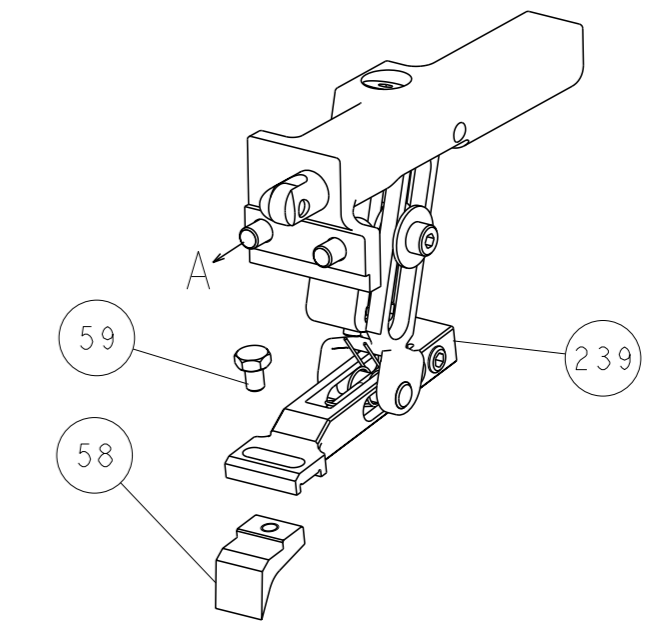

PNEUMATIC

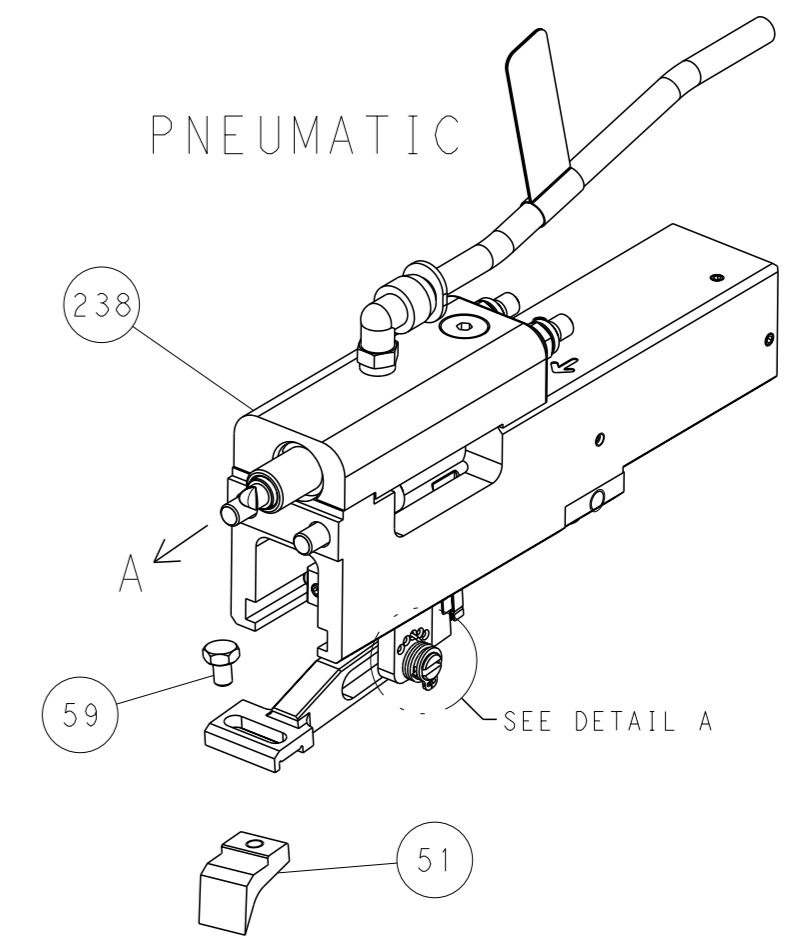

FEED SPRING
SETTING POSITION

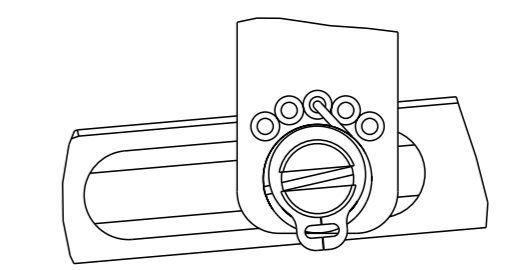

DETAIL A

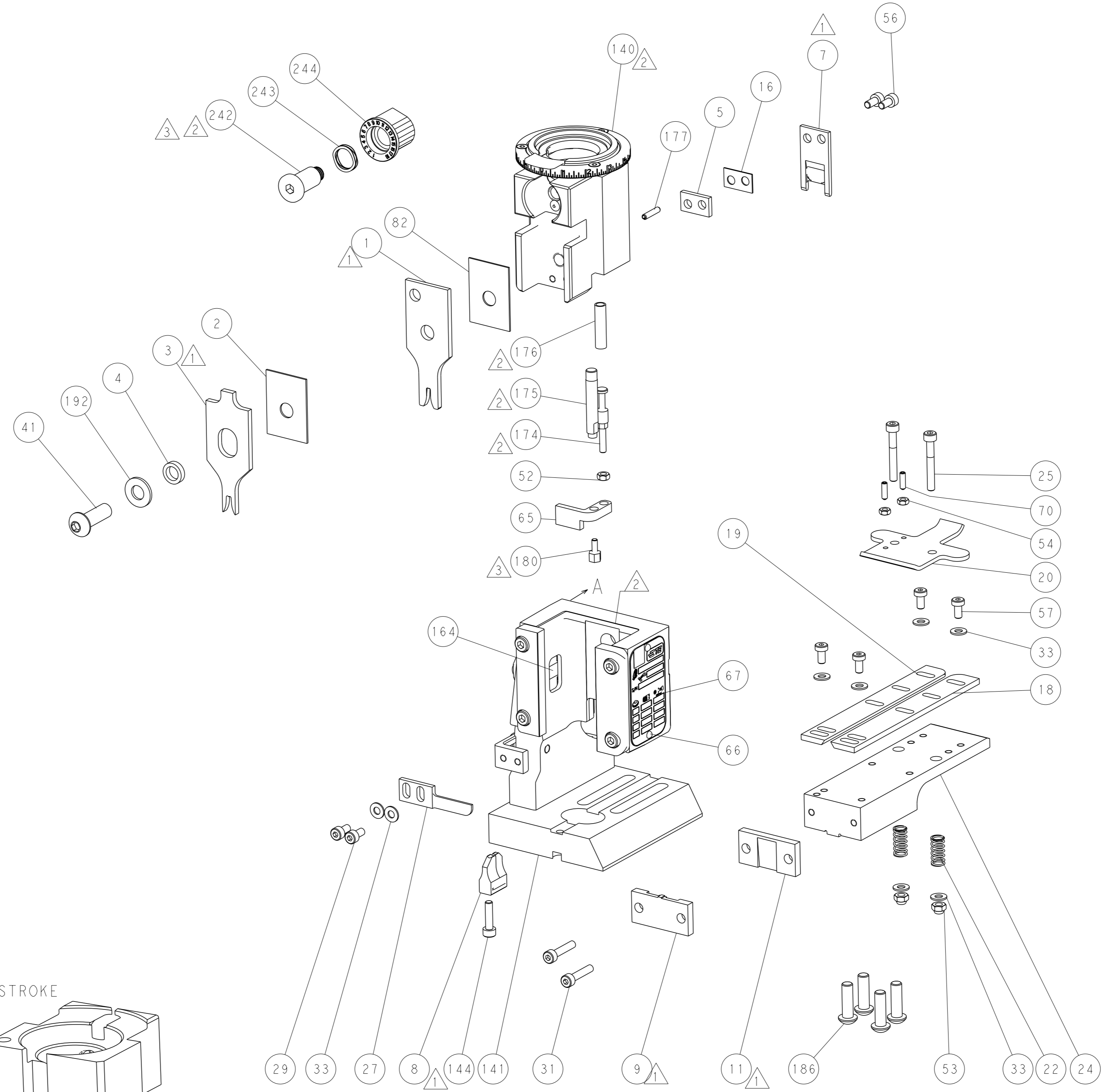

CAM POSITIONS

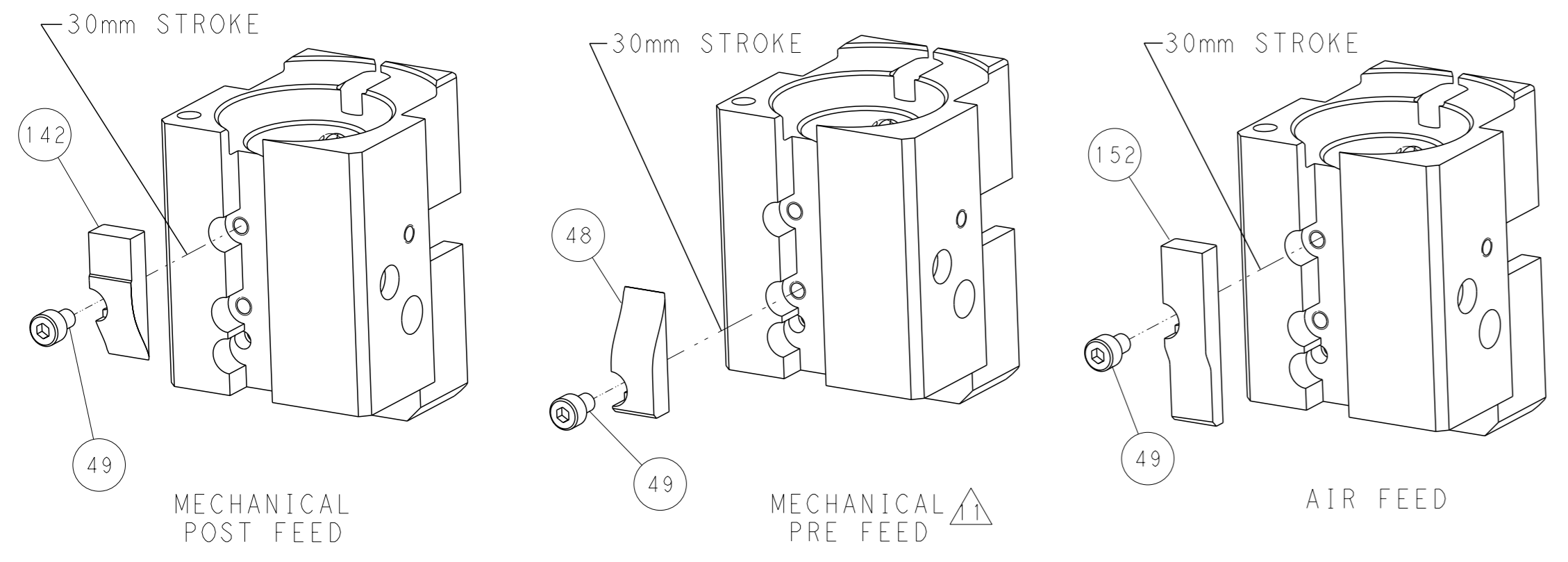

PACIFIC VERSION
 Shown on sheets 3 of 4 & 4 of 4
 (Atlantic version shown on sheets 1 of 4 & 2 of 4)

DIMENSIONS: mm 		TOLERANCES UNLESS OTHERWISE SPECIFIED: 0 PLC ± 1 PLC ± 2 PLC ± 3 PLC ± 4 PLC ± ANGLES FINISH ±		OWN: L. ZHANG CHK: L. ZHANG APVD: S. XI PRODUCT SPEC APPLICATION SPEC WEIGHT: - CUSTOMER ACCESSIBLE PRODUCTION DRAWING	DATE: 07FEB2012 NAME: Ocean End Feed Applicator SIZE: A1 SCALE: 1:1 SHEET: 4 of 4 REV: E	TE Connectivity Harrisburg, PA 17105-3608 CAGE CODE: 00779 DRAWING NO: 2150081	RESTRICTED TO
--------------------	--	--	--	--	---	---	---------------