

CX02067

3.3 Volt Laser Driver IC for GbE and Fibre Channel to 2.1 Gbps Data Sheet

- Features
- Description
- Applications
- Pin Descriptions
- Measurement Tables
- Functional Description

3.3 Volt Laser Driver IC for GbE and Fibre Channel to 2.1 Gbps

TABLE OF CONTENTS

Table 1 Ordering Information	3
Revision History	3
Features	4
Applications	4
Description	4
Connections	4
Table 2 Pin Description	5
Table 3 Absolute Maximum Ratings	6
Table 4 Recommended Operating Conditions	6
Table 5 AC Characteristics	6
Table 6 DC Characteristics	7
Functional Diagram	8
Functional Description	8
Overview	8
Modulator	8
Electrical Eye Diagram	9
Mean Power Control Loop	10
Table 7 MPC Loop Bandwidth	10
Enable Control	10
Current Monitors	10
Slow-Start	11
Temperature Compensation	11
Laser eye safety	12
BCC+24L Package Outline	13
Disclaimer	14

Ordering Information

Part Number	Package
M02067-09-T	BCC+24
M02067G-09-T	BCC+24 (RoHS Compliant)
Current part number ordering information for this part on mindspeed.com	
* The letter "G" designator after the part number indicates that the device is RoHS-compliant. Refer to www.mindspeed.com for additional information.	

Revision History

Revision	Level	Date	Description
C	Preliminary	October 2007	Added RoHS package information, updated format, no specification changes.
B	Preliminary	April 2002	

3.3 Volt Laser Driver IC for GbE and Fibre Channel to 2.1 Gbps

FEATURES

- ❑ Rise and fall times <150 ps
- ❑ DC or AC-coupled modulation drive.
- ❑ Independently Programmable Laser Bias and Modulation currents.
- ❑ Bias current to 100 mA and modulation current to 85 mA at $V_{CC} = 3.3\text{ V}$
- ❑ Automatic Laser Power Control, with programmable Temperature Compensation and 'Slow-Start'.
- ❑ Bias and modulation current monitors
- ❑ Operates with +3.3 Volt supply
- ❑ Small BCC+24 package

DESCRIPTION

The CX02067 is a highly integrated, programmable laser driver intended for Datacom applications up to 2.1 Gbps. Using differential PECL data inputs, the CX02067 supplies the bias and modulation current for driving an edge-emitting laser. The modulation output can be DC-coupled to the laser diode, giving a significant power saving over AC-coupled operation.

The CX02067 includes automatic power control to maintain a constant average laser output power over temperature and life. In addition, the modulation current is temperature compensated to minimize variation in extinction ratio over temperature.

Output flags indicate laser end of life as well as failure of the APC circuitry to maintain average output power.

APPLICATIONS

- ❑ Gigabit Ethernet
- ❑ Fibre Channel
- ❑ 2 x Fibre Channel
- ❑ GBIC

CONNECTIONS

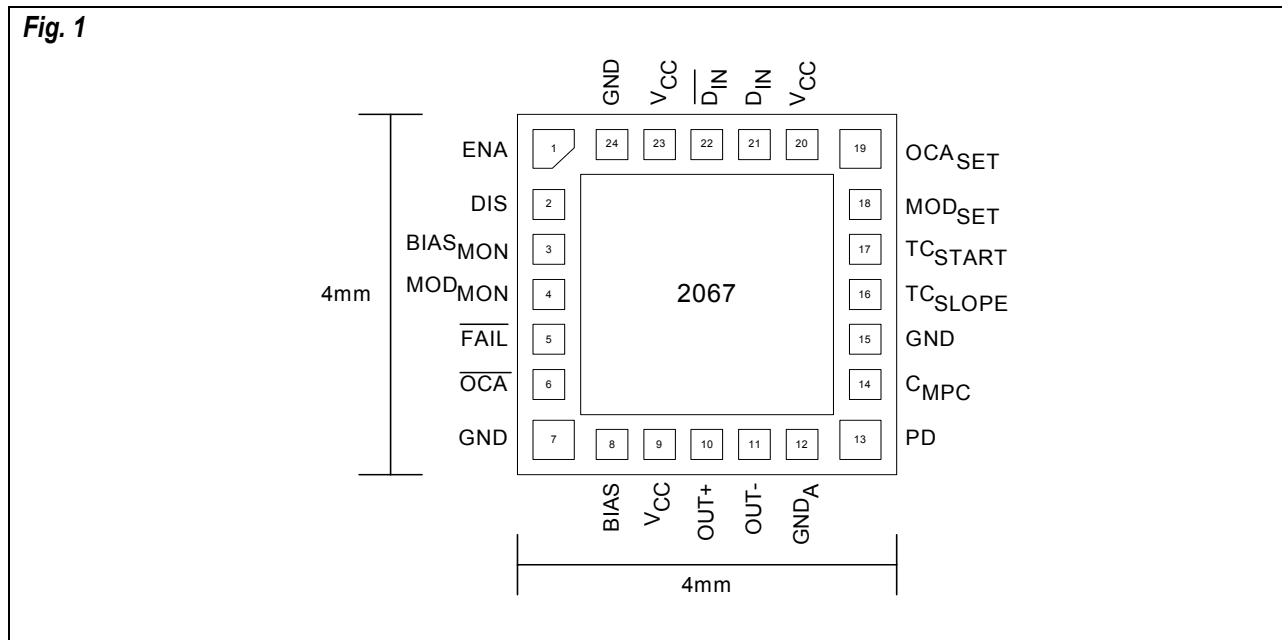

3.3 Volt Laser Driver IC for GbE and Fibre Channel to 2.1 Gbps

TABLE 2. PIN DESCRIPTION

BCC+24 Pin No	Name	Function
1	ENA	Bias and modulation output enable (TTL/CMOS). Logic HIGH for normal operation
2	DIS	Bias and modulation output disable (TTL/CMOS). Logic LOW for normal operation
3	BIAS _{MON}	Bias monitor. Connect a resistor between this pin and V _{CC} to monitor bias current. Connect to V _{CC} if not used
4	MOD _{MON}	Modulation monitor. Connect a resistor between this pin and V _{CC} to monitor modulation current. Connect to V _{CC} if not used
5	$\overline{\text{FAIL}}$	Mean power control failure indicator (TTL/CMOS). Goes LOW when control loop is no longer able to maintain constant current at PD
6	$\overline{\text{OCA}}$	Over-current alarm (TTL/CMOS). Goes LOW when I _{BIAS} exceeds the preset bias current limit
7	GND	Ground
8	BIAS	Laser bias current output
9	V _{CC}	Power supply
10	OUT+	Positive modulation current output. Sinks current when D _{IN} is HIGH
11	OUT-	Negative modulation current output. Sinks current when $\overline{\text{D}}_{\text{IN}}$ is HIGH
12	GND _A	Ground to output stage.
13	PD	Monitor photodiode input. This input is connected to the monitor photodiode anode for automatic power control
14	C _{MPC}	Mean power control dominant pole capacitor. Connect to V _{CC} via a capacitor
15	GND	Ground
16	TC _{SLOPE}	Connecting a resistor between this pin and ground sets the temperature coefficient of I _{MODSET}
17	TC _{START}	Secondary temperature coefficient of I _{MOD} . A resistor on this pin to ground sets the threshold temperature at which compensation starts
18	MOD _{SET}	Modulation current set. Connect a resistor between this pin and ground to set
19	OCA _{SET}	Over-current alarm set. Connect a resistor between this pin and ground to set
20	V _{CC}	Power supply
21	D _{IN}	Positive data input (PECL). Self biased
22	$\overline{\text{D}}_{\text{IN}}$	Negative data input (PECL). Self biased
23	V _{CC}	Power supply
24	GND	Ground

Note :

Pin 25, the center pad should be connected to ground.

3.3 Volt Laser Driver IC for GbE and Fibre Channel to 2.1 Gbps

TABLE 3 _____ ABSOLUTE MAXIMUM RATINGS

Parameter	Rating	Units
Power supply (V_{CC-GND})	-0.5 to +6.0	V
Maximum laser bias current	120	mA
Maximum laser modulation current (through OUT+, OUT-)	100	mA
Storage temperature	-65 to +150	°C
Junction temperature (die)	-40 to +120	°C

These are the absolute maximum ratings at or beyond which the IC can be expected to fail or be damaged. Reliable operation at these extremes for any length of time is not implied.

TABLE 4 _____ RECOMMENDED OPERATING CONDITIONS

Parameter	Rating	Units
Power supply (V_{CC-GND})	$3.3 \pm 10\%$	V
Operating ambient temperature	-40 to +85	°C

TABLE 5 _____ AC CHARACTERISTICS

Parameter	Conditions	Min.	Typ.	Max.	Units
Differential input voltage	$= 2 \times (D_{IN+HIGH} - D_{IN+LOW})$	300	-	1860	mV
Modulation current range		2.5	-	85	mA
Modulation current with output disabled	DIS = HIGH	-	-	300	μA
Programmable range for modulation current temperature coefficient	Adjustable	500	-	10^4	ppm/°C
Programmable temperature at which modulation current TC compensation enables	Programmed by choice of $R_{TCSLOPE}$	20	-	60	°C
Modulation output rise/fall times	20% to 80% into 25Ω , with matching network	-	-	150	ps
Overshoot of modulation output current	Into 25Ω load, with matching network	-5	-	+5	%
Modulation output Pulse width distortion	Measured using alternating 1-0 pattern	-	-	50	ps
Modulation output deterministic jitter	Peak-to-peak. Measured into 25Ω load using 27^{-1} PRBS at 2.1 Gbps	-	-	50	ps

($V_{CC} = +3.3 \text{ V} \pm 10\%$, $T_A = -40 \text{ °C}$ to $+85 \text{ °C}$, unless otherwise noted)

3.3 Volt Laser Driver IC for GbE and Fibre Channel to 2.1 Gbps

TABLE 6 _____ DC CHARACTERISTICS

Parameter	Conditions	Min.	Typ.	Max.	Units
Supply current	Excluding I _{BIAS} and I _{MOD} but with I _{BIAS} and I _{MOD} set to maximum	-	52	64	mA
Bias current adjust range	Limited by I _{REF} across temperature range	4	-	100	mA
Bias current with output disabled	Tx-Dis = HIGH	-	-	300	µA
Maximum bias current limit	T _A = +85 °C (adjustable)	100 ⁽¹⁾	-	-	mA
Monitor diode reverse bias voltage		2	-	-	V
Monitor diode current adjustment range		40	-	1000	µA
TTL/CMOS input HIGH voltage (enable/disable)		2.0	-	-	V
TTL/CMOS input LOW voltage (enable/disable)		-	-	0.8	V
CMOS output HIGH voltage (Fail,OCA)		2.4	-	-	V
CMOS output LOW voltage (Fail,OCA)		-	-	0.4	V
Differential input impedance	Data and clock inputs	2.5	-	-	kΩ
Common-mode input voltage ⁴		V _{CC} -1.38	-	$V_{CC} - \frac{V_{IN(Diff)}}{4}$	V
Self-biased common mode input voltage	Data and clock inputs	V _{CC} -1.38	-	V _{CC} -0.47	V
Ratio of bias monitoring current, and bias current			55		
Ratio of modulation monitoring current, and modulation current			55		
Tx_Disable negate time ⁽²⁾	C _{MPC} = 3.8 nF		.5	1	ms
Tx_Disable assert time ⁽³⁾				1	µs

(V_{CC} = +3.3 V ±10%, T_A = -40 °C to +85 °C, unless otherwise noted)

Note:

- (1) Condition when pin 19 OCA_{SET} is connected to ground.
- (2) Time for optical power to reach 90% of its mean level following negation of Tx_Disable.
- (3) Time for optical power to reach 10% of its mean level following assertion of Tx_Disable.

3.3 Volt Laser Driver IC for GbE and Fibre Channel to 2.1 Gbps

FUNCTIONAL DIAGRAM

Fig. 2

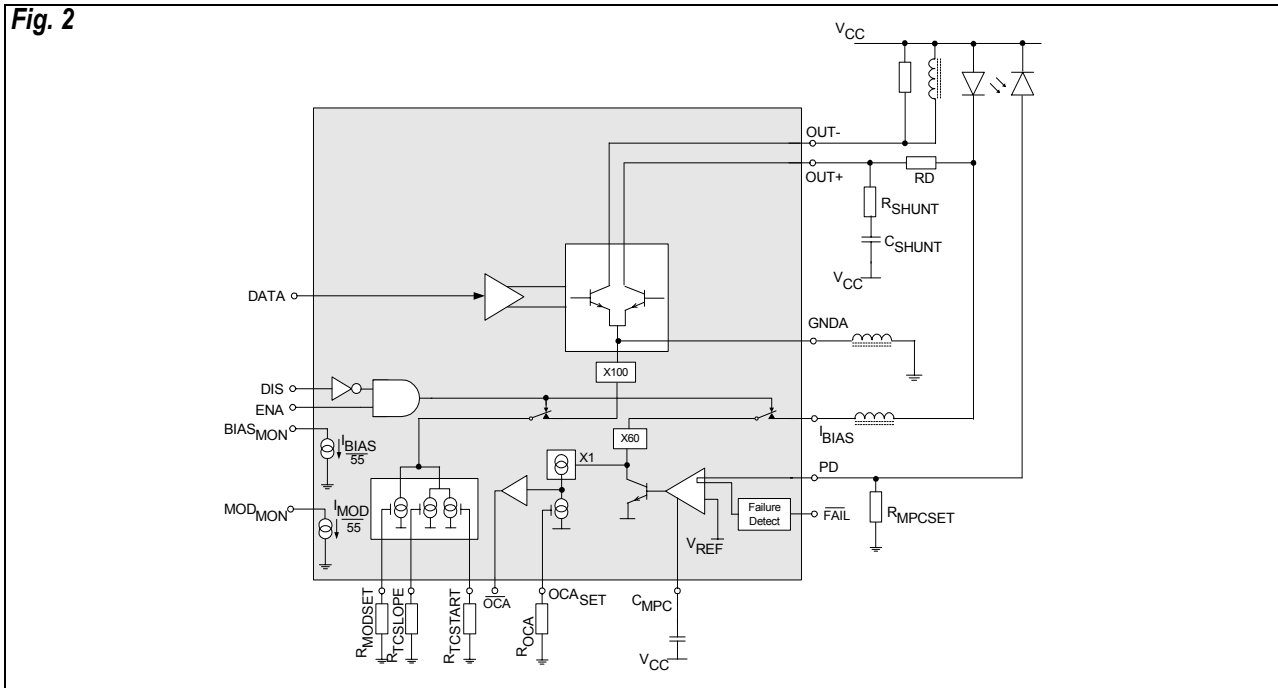

FUNCTIONAL DESCRIPTION

Overview

The CX02067 laser driver consists of a high-speed modulation driver and a laser bias generator with mean power control (MPC). It is optimized for high speed, low power operation at 3.3 V supply. Fig. 2 demonstrates the functionality of the CX02067.

Fig. 3

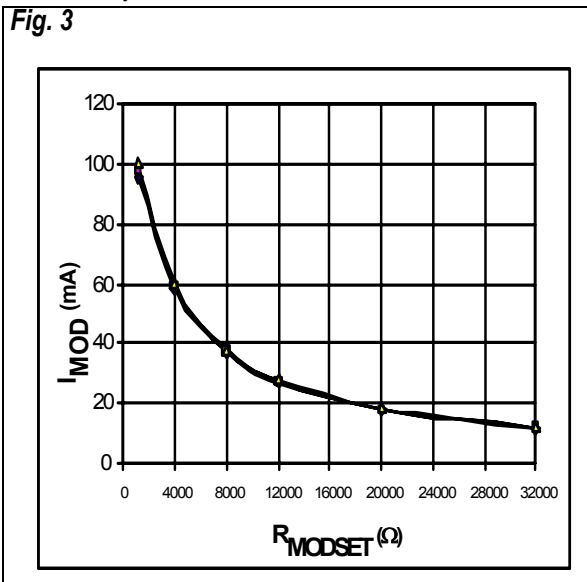

Modulator

The modulator output stage is designed to drive up to 85 mA in either AC-coupled or DC-coupled mode. DC-coupled performance depends on the laser used.

The CX02067 modulation output is optimized for driving a 25 Ω load; the minimum required voltage at OUT+ and OUT- is 0.6 V. To interface with the laser diode, a matching resistor (RD) is required for impedance matching. An RC shunt network is necessary to compensate for the laser diode parasitic inductance, thereby improving the optical eye. Typical values are R_SHUNT = 51 Ω, C_SHUNT = 3.3 pF

Any capacitive loading at the cathode of a laser diode will degrade the optical output performance. An inductor is used to isolate the BIAS pin from the laser cathode.

Fig. 3 shows the typical I_MOD vs R_MODSET characteristic.

3.3 Volt Laser Driver IC for GbE and Fibre Channel to 2.1 Gbps

ELECTRICAL EYE DIAGRAM

Fig. 4

Fibre Channel 1.0625 Gbps

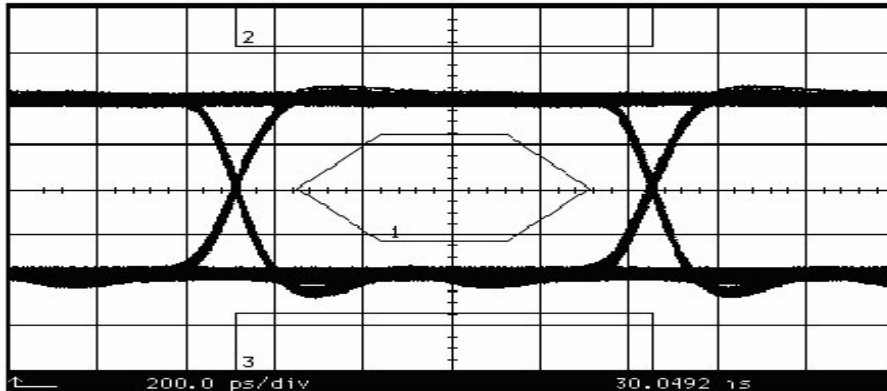

30 mApp Modulation Current

Gigabit Ethernet 1.25 Gbps

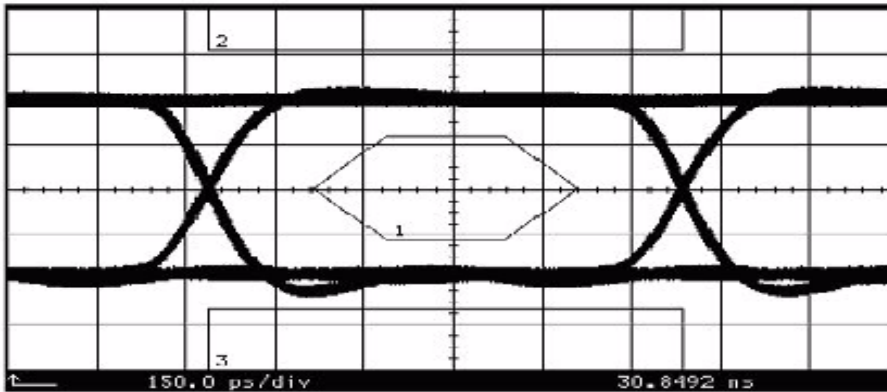

30 mApp Modulation Current

2 x Fibre Channel 2.125 Gbps

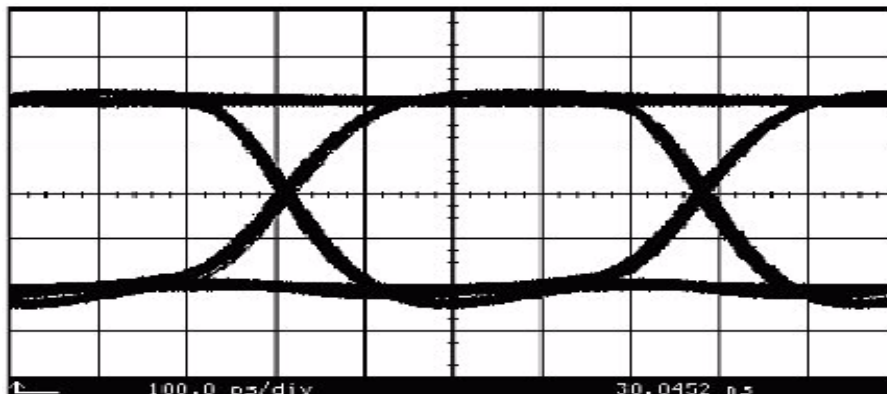

30 mApp Modulation Current

3.3 Volt Laser Driver IC for GbE and Fibre Channel to 2.1 Gbps

FUNCTIONAL DESCRIPTION

Mean Power Control Loop

The CX02067 employs a Mean Power Control (MPC) loop to maintain a constant optical output power from the laser across temperature, time and power supply variations. Laser diodes used for communication purposes come with integrated photo-diodes to monitor the output power and provide the feedback for the MPC loop. The MPC loop (or its integrated safety features) cannot be used without this feedback.

The MPC loop adjusts the laser bias current so that the monitor current from the photo-diode is matched to a reference current set by a single external resistor, R_{MPCSET} . The time constant of the MPC loop is determined by C_{MPC} .

TABLE 7 MPC LOOP BANDWIDTH

C_{MPC}	6 dB cutoff frequency
0	17 MHz
1 nF	100 kHz
10 nF	10 kHz
100 nF	1 kHz

(at 6 dB cut off frequency) vs C_{MPC} (for nominal process)

Fig. 5 shows the bias current vs R_{MPCSET} over the full operating temperature range

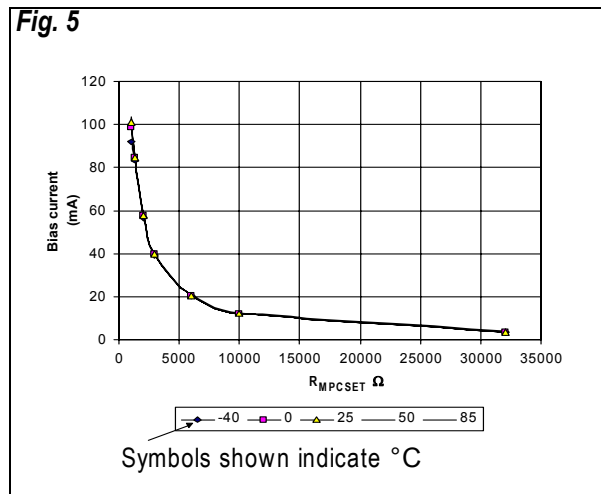

There are two safety features integrated into the MPC loop; an Over-Current Alarm and an MPC loop failure alarm.

The **Over-Current Alarm (OCA)** circuit limits the maximum bias current generated by the CX02067. The bias current limit is set by an external resistor to ground, R_{OCA} . When this limit is exceeded the \overline{OCA} pin is asserted LOW. Fig. 6 shows the maximum bias current limit vs R_{OCA} .

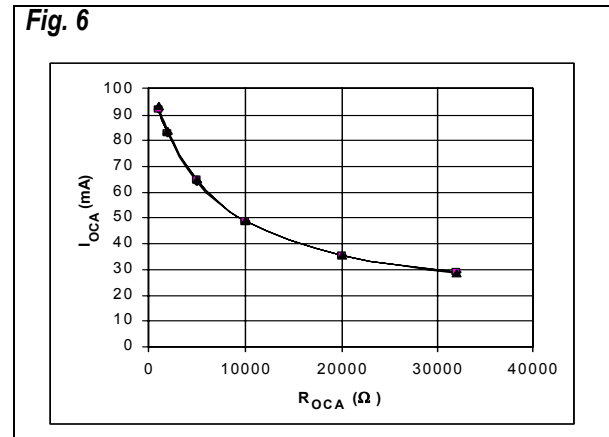

The **MPC loop FAILURE alarm (FAIL)** is generated by the CX02067 when the MPC loop can no longer maintain the constant current set by R_{MPCSET} . When the MPC loop failure alarm is triggered the FAIL pin is asserted LOW.

Enable Control

The CX02067 incorporates a dual polarity laser enable function with both enable (ENA) and disable (DIS) inputs.

Under normal operating conditions the ENA will be HIGH while DIS is LOW. Should ENA go LOW (or DIS go HIGH) both the bias and modulation currents will be disabled.

Wire OR-ing the OCA and FAIL pins externally and connecting them to the ENA pin will automatically disable the bias and modulation currents when a failure occurs.

Current Monitors

The CX02067 features bias and modulation current monitor outputs. The $BIAS_{MON}$ output sinks a current equal to nominally 1/55 of the laser bias current (I_{BIAS}). The MOD_{MON} output sinks a current equal to nominally 1/55 of the laser modulation current (I_{MOD}). $BIAS_{MON}$ and MOD_{MON} should be connected through a pull-up resistor to V_{CC} . Choose a pull-up resistor value that ensures a voltage at $BIAS_{MON}$ greater than $V_{CC} - 1.6$ V and a voltage at MOD_{MON} greater than $V_{CC} - 1.0$ V. These pins should be tied to V_{CC} if not used.

3.3 Volt Laser Driver IC for GbE and Fibre Channel to 2.1 Gbps

FUNCTIONAL DESCRIPTION

Slow-Start

For laser safety and reliability, the CX02067 incorporates a slow-start circuit that provides a delay of approximately 200 ns before enabling the laser diode.

Temperature Compensation

The CX02067 features built in temperature compensation of the modulation current is set using two external resistors, TC_{SLOPE} and TC_{START} see Fig. 7.

Current pulled from TC_{SLOPE} adjusts the slope of the temperature compensation whereas current pulled from TC_{START} sets the threshold temperature for the coefficient.

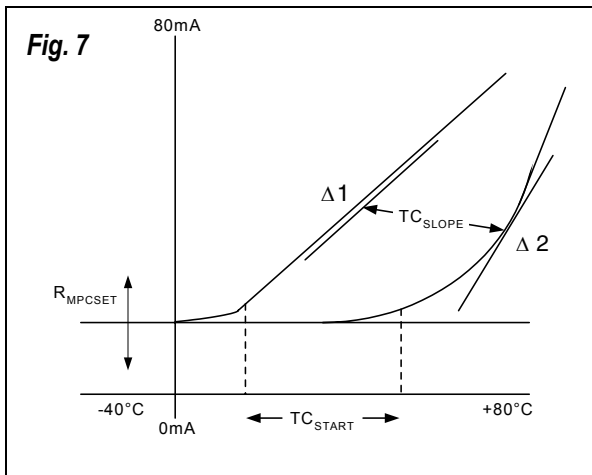

Fig. 7

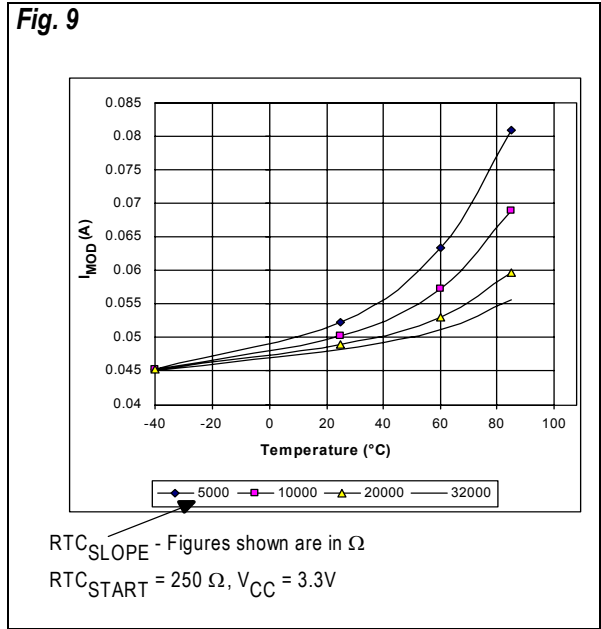

Fig. 9

RTC_{SLOPE} - Figures shown are in Ω
 $RTC_{START} = 250 \Omega, V_{CC} = 3.3V$

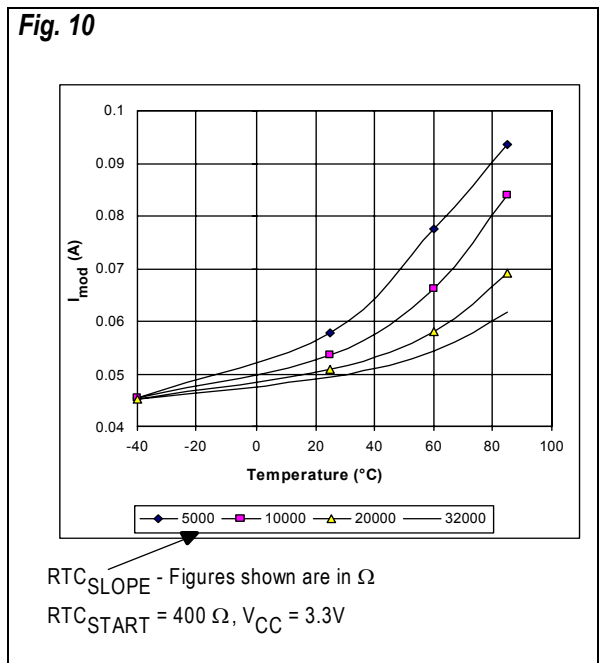

Fig. 10

RTC_{SLOPE} - Figures shown are in Ω
 $RTC_{START} = 400 \Omega, V_{CC} = 3.3V$

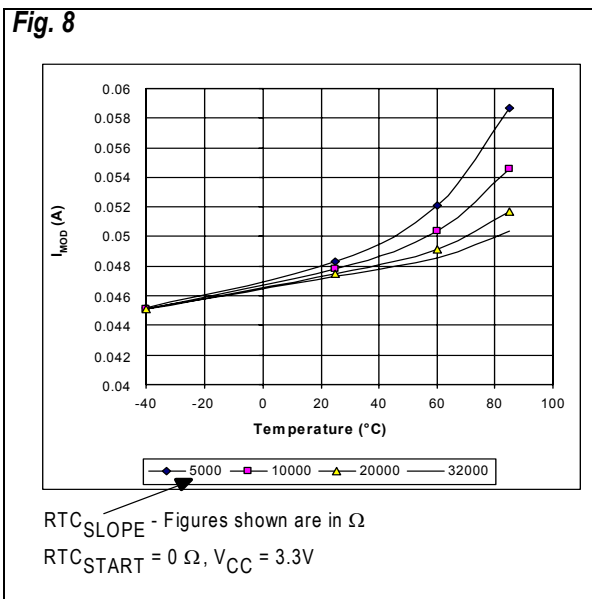

Fig. 8

RTC_{SLOPE} - Figures shown are in Ω
 $RTC_{START} = 0 \Omega, V_{CC} = 3.3V$

Fig. 8 to 10 shows I_{MOD} temperature compensation using a combination of resistor values for RTC_{SLOPE} and RTC_{START} .

3.3 Volt Laser Driver IC for GbE and Fibre Channel to 2.1 Gbps

LASER EYE SAFETY

Laser eye safety

All lasers for commercial and industrial use, including lasers for optical communications are classified for eye safety considerations in IEC 60825-1, CDRH and other national standards.

IMPORTANT NOTE:

The CX02067 alone does NOT ensure that any application within which it is used will be fully compliant with the relevant eye-safety requirements.

It remains the sole responsibility of the user of this component to ensure that the application within which the CX02067 is used meets all eye-safety requirements.

3.3 Volt Laser Driver IC for GbE and Fibre Channel to 2.1 Gbps

BCC+24L PACKAGE OUTLINE

Fig. 12

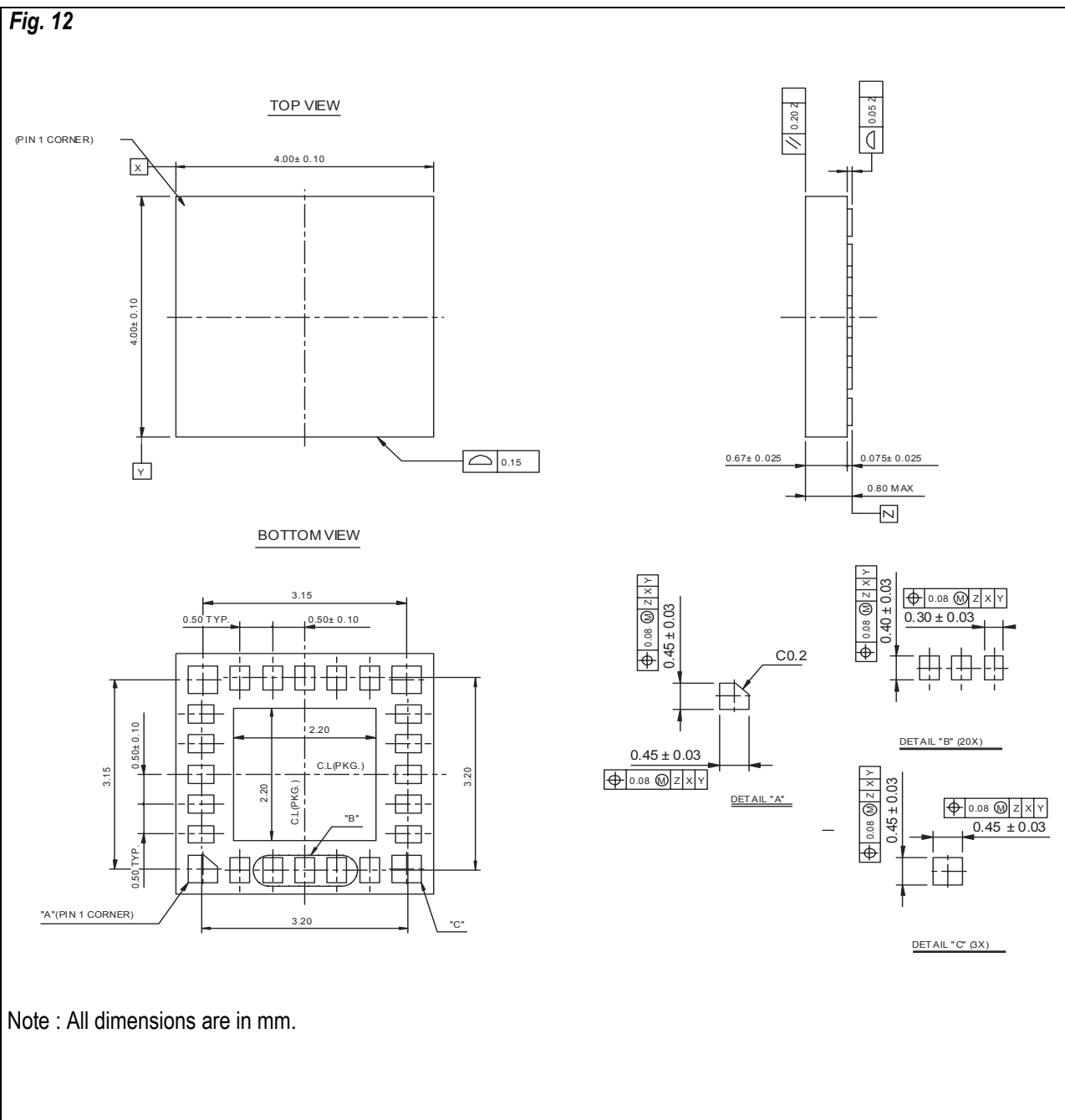

Note : All dimensions are in mm.

3.3 Volt Laser Driver IC for GbE and Fibre Channel to 2.1 Gbps

DISCLAIMER

Company Headquarters

Mindspeed Technologies
4000 MacArthur Boulevard, East Tower
Newport Beach, CA 92660
Phone: (949) 579-3000
Fax: (949) 579-3020

© 2001-2007 Mindspeed Technologies™ All Rights Reserved.

Information in this document is provided in connection with Mindspeed Technologies. "Mindspeed" products. These materials are provided by Mindspeed as a service to its customers and may be used for informational purposes only. Mindspeed assumes no responsibility for errors or omissions in these materials. Mindspeed may make changes to specifications and product descriptions at any time, without notice. Mindspeed makes no commitment to update the information contained herein. Mindspeed shall have no responsibility whatsoever for conflicts or incompatibilities arising from future changes to its specifications and product descriptions.

No license, express or implied, by estoppel or otherwise, to any intellectual property rights is granted by this document. Except as provided in Mindspeed Terms and Conditions of Sale for such products, Mindspeed assumes no liability whatsoever.

THESE MATERIALS ARE PROVIDED "AS IS" WITHOUT WARRANTY OF ANY KIND, EITHER EXPRESS OR IMPLIED, RELATING TO SALE AND/OR USE OF CONEXANT PRODUCTS INCLUDING LIABILITY OR WARRANTIES RELATING TO FITNESS FOR A PARTICULAR PURPOSE, MERCHANTABILITY, OR INFRINGEMENT OF ANY PATENT, COPYRIGHT OR OTHER INTELLECTUAL PROPERTY RIGHT. Mindspeed further does not warrant the accuracy or completeness of the information, text, graphics or other items contained within these materials. Mindspeed shall not be liable for any special, indirect, incidental, or consequential damages, including without limitation, lost revenues or lost profits, which may result from the use of these materials.

Mindspeed products are not intended for use in medical, life saving or life sustaining applications. Mindspeed customers using or selling Mindspeed products for use in such applications do so at their own risk and agree to fully indemnify Mindspeed for any damages resulting from such improper use or sale.

Reader Response: Mindspeed Technologies, strives to produce quality documentation and welcomes your feedback. Please send comments and suggestions to <mailto:tech.pubs@mindspeed.com>. For technical questions, or to talk to a field applications engineer contact your local Mindspeed™ sales office listed below. For literature send email request to literature@mindspeed.com.

Preliminary Information