

4

3

2

1

THIS DRAWING IS UNPUBLISHED. RELEASED FOR PUBLICATION .19
 © COPYRIGHT 19 BY AMP INCORPORATED. ALL RIGHTS RESERVED.

LOC	DIST	REVISIONS					
G	86	P	LTR	DESCRIPTION	DATE	DWN	APVD
		D		Add N in the stamp note 1	11OCT2017	LG	MV

Ⓧ ⚠ STAMP AMP 400 MCM N 1100/24 APPROX AS SHOWN

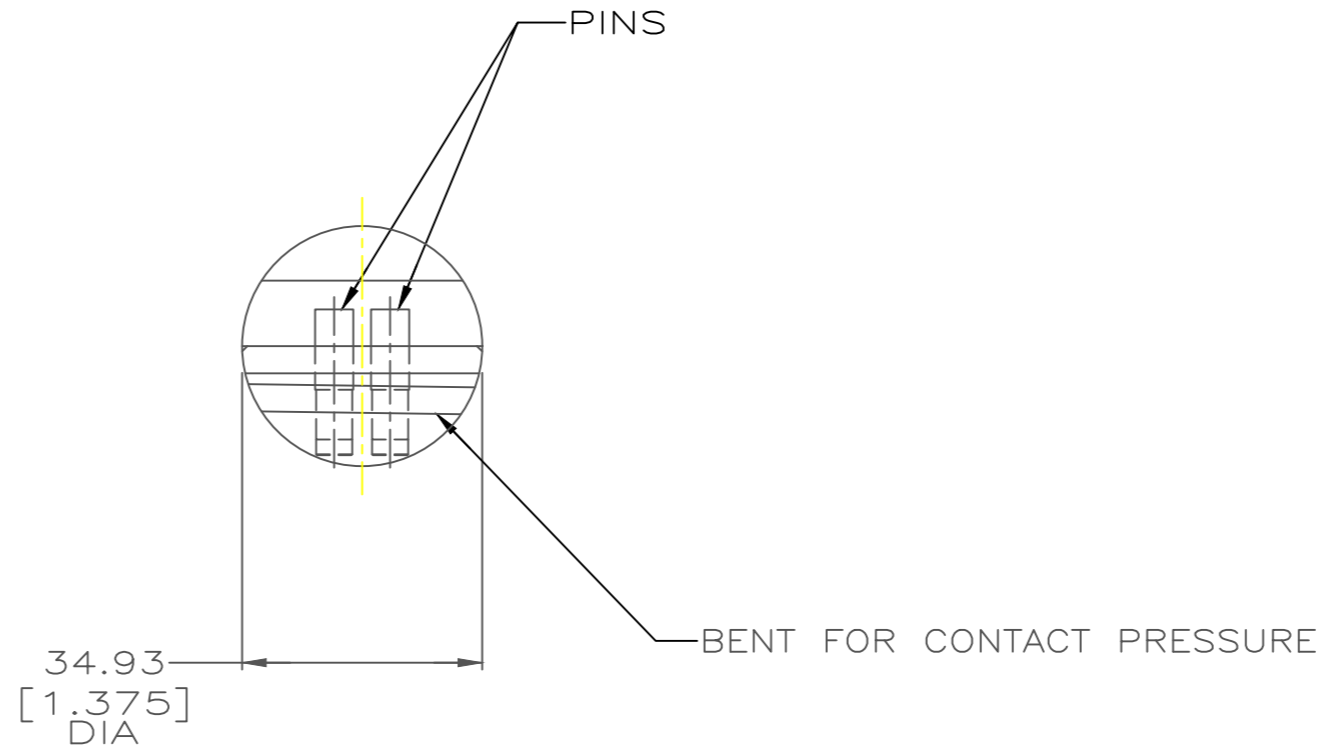
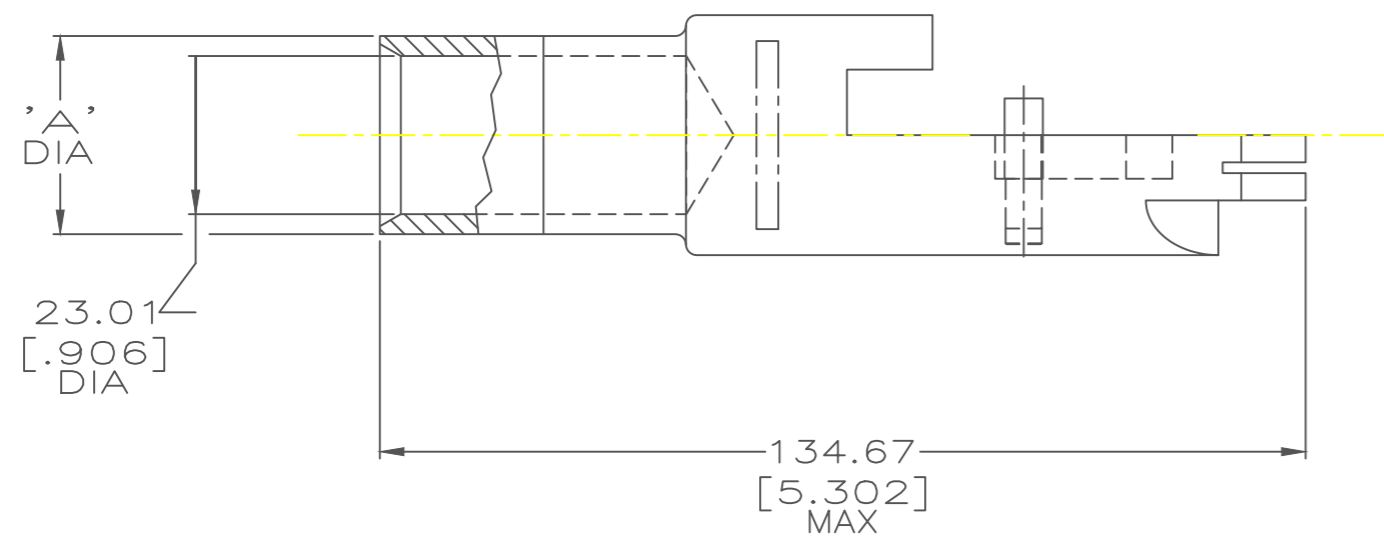
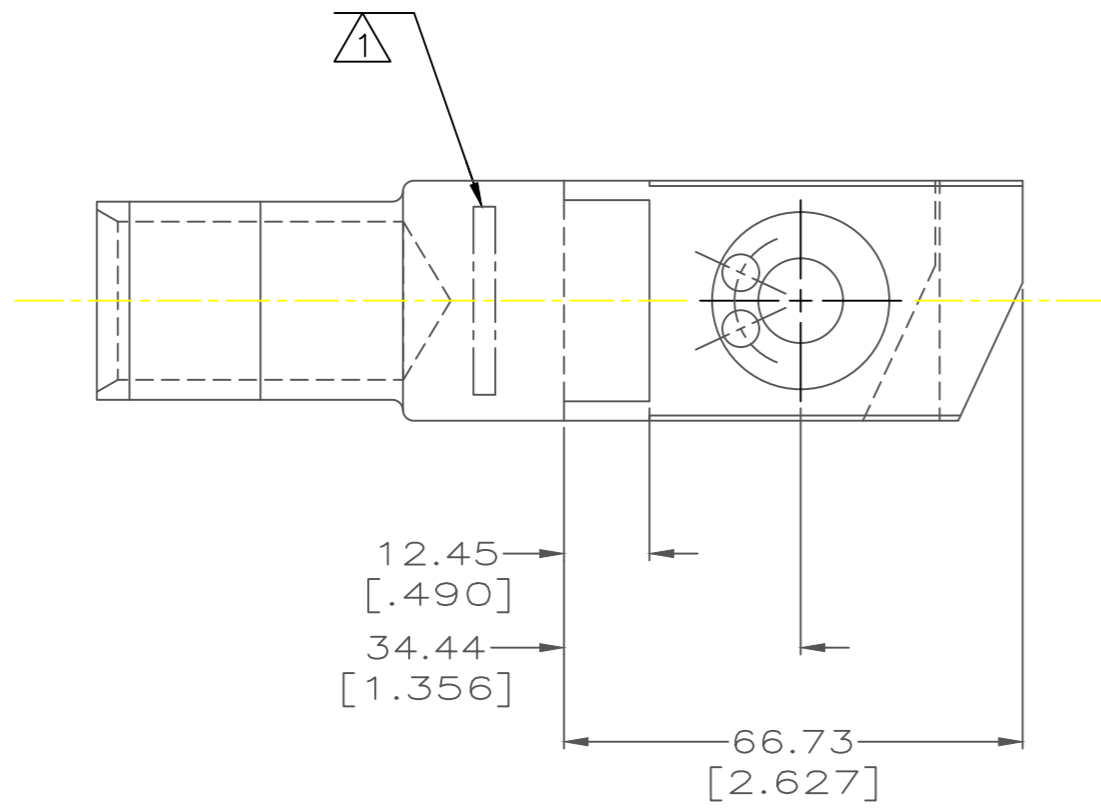

30.48 [1.200]	53434-2
28.83 [1.135]	53434-1
'A'	AMP PART NUMBER

THIS DRAWING IS A CONTROLLED DOCUMENT FOR AMP INCORPORATED. IF IT IS SUBJECT TO CHANGE AND THE CONTROLLING ENGINEERING ORGANIZATION SHOULD BE CONTACTED FOR THE LATEST REVISION.		DWN	DK SCHRUM	14JUN96	AMP AMP Incorporated Harrisburg, PA 17105-3608
DIMENSIONS: mm[INCHES]		CHK	WJ VOCKROTH	25JUN96	
TOLERANCES UNLESS OTHERWISE SPECIFIED: 0 PLC ±- 1 PLC ±- 2 PLC ±0.20[.008] 3 PLC ±- 4 PLC ±- ANGLES ±-		APVD	JL MECKLEY	25JUN96	NAME
MATERIAL BODY & PINS BRASS PER QQ-B-626		PRODUCT SPEC 108-13014		TERMINAL ASSEMBLY, QUICK-DISCONNECT, AMPOWER™, WIRE SIZE: 400 MCM	
FINISH SILVER PL 0.00127[.000050] MIN THK PER QQ-S-365		APPLICATION SPEC	SIZE		CAGE CODE
CUSTOMER DRAWING		WEIGHT		A2	00779
		DRAWING NO		C=53434	
		SCALE		1:1	SHEET 1 OF 1 REV D

53434

A