

THIRD GENERATION POLARIZATION

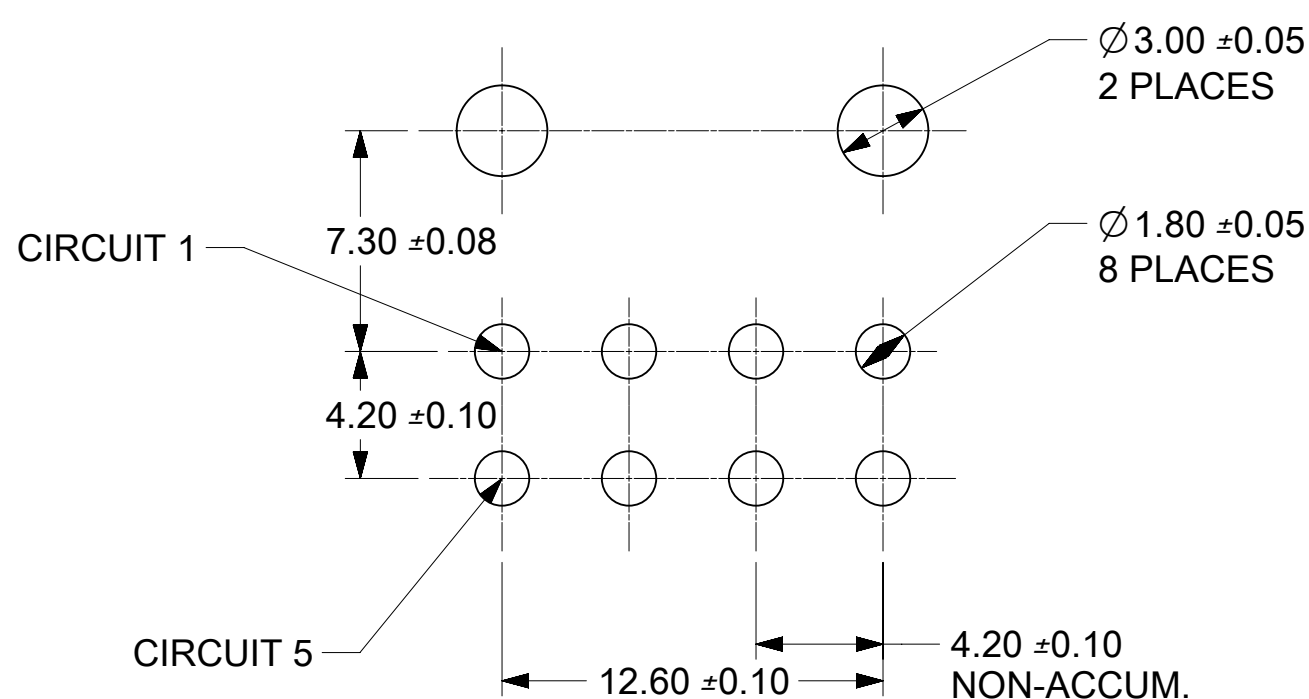

RECOMMENDED HOLE LAYOUT FOR 1.78 MAX. THICK P.C. BOARD. VIEWED FROM COMPONENT SIDE OF BOARD

PART NUMBER	POLARIZATION TYPE	PLATING OPTION	PACKAGING	PIN IDENTIFICATION PER CIRCUIT, SEE NOTE 7								
				CKT. 1	CKT. 2	CKT. 3	CKT. 4	CKT. 5	CKT. 6	CKT. 7	CKT. 8	
455860005	THIRD GENERATION	GS	TRAY	STD.	STD.	STD.	STD.	STD.	STD.	STD.	STD.	STD.
455860006	THIRD GENERATION	GS	TAPE & REEL	STD.	STD.	STD.	STD.	STD.	STD.	STD.	STD.	STD.

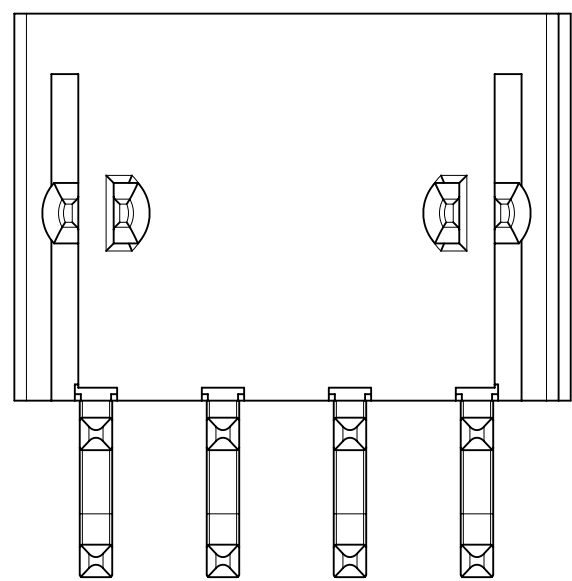
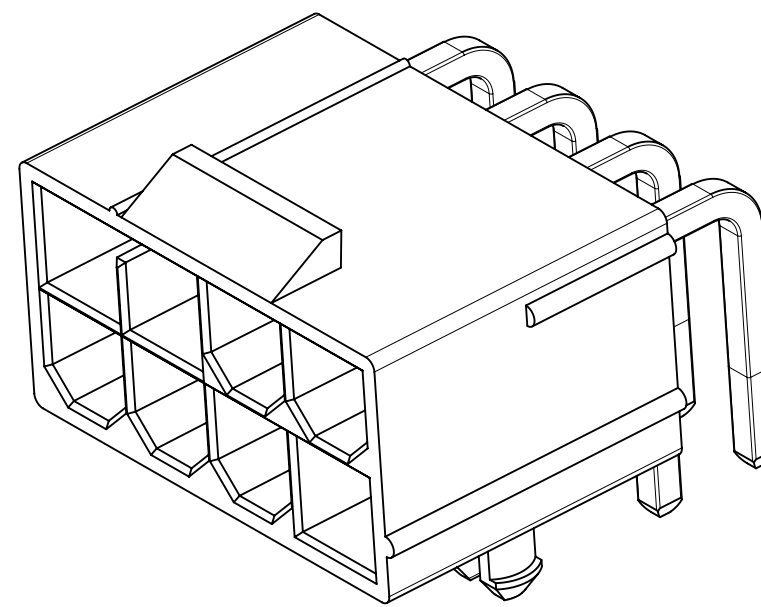
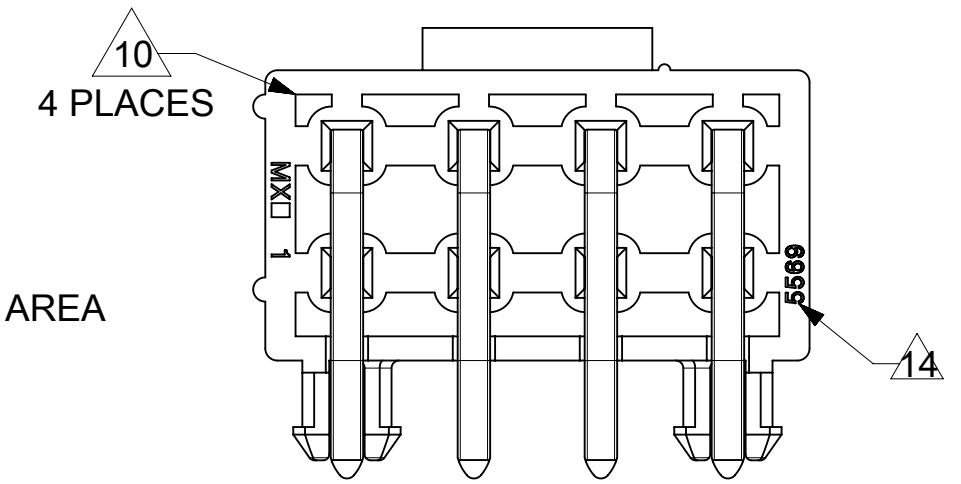
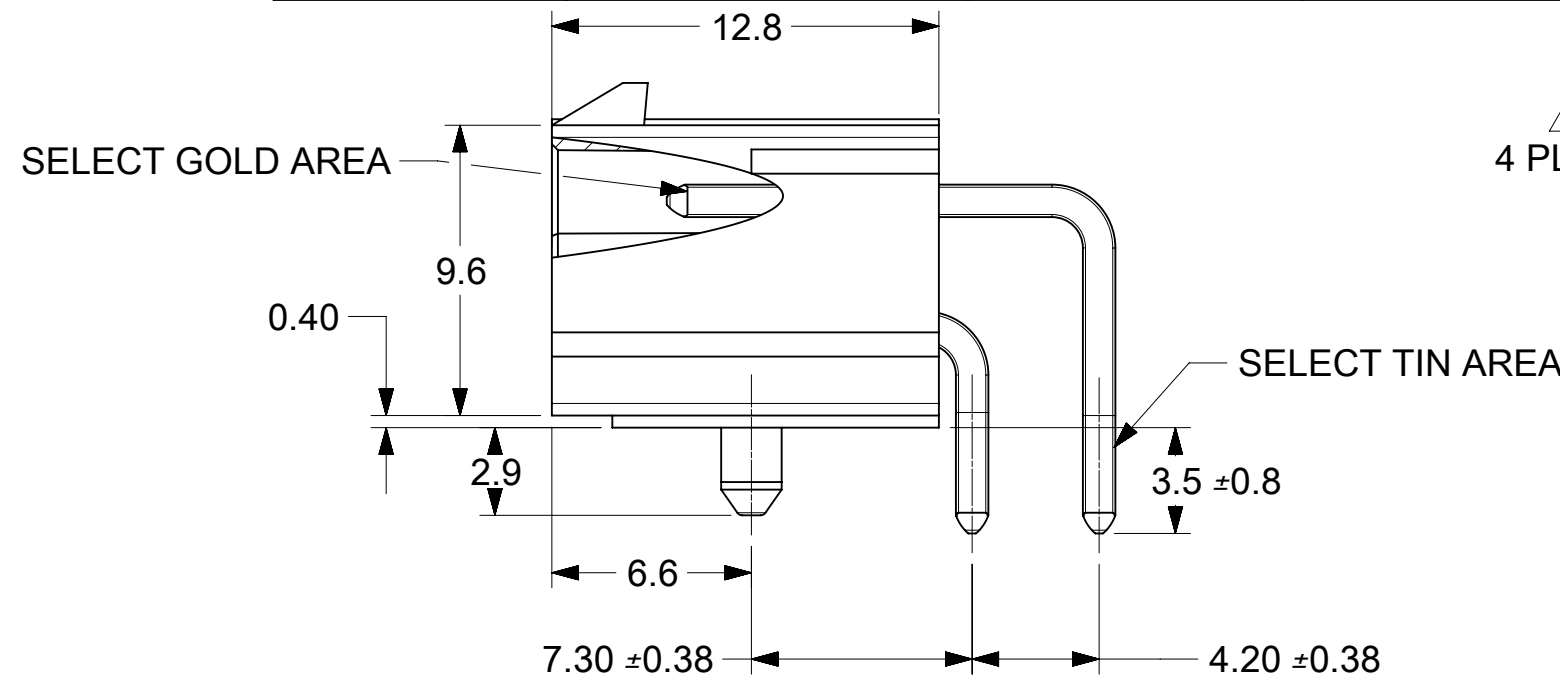

NOTES:

- MATERIAL:
HOUSING: NYLON, UL94V-0, COLOR: BLACK
TERMINAL: BRASS
- FINISH (TERMINAL PLATING):
"GS" = .000030/(0.00076) MIN. SELECT GOLD AND .000100/(0.00254) SELECT MATTE TIN OVER .000050/(0.00127) NICKEL OVERALL
- PRODUCT SPECIFICATION: PS-5556-001
- PACKAGING:
"TRAY" PER PK-5569-003
"TAPE & REEL" PER RPK-5569-004
- 455860005 & 455860006 HEADER ASSEMBLIES MATE WITH 455870004 RECEPTACLE HOUSING.
- PART IS NOT DESIGNED FOR CURRENT SHARING.
- PIN I.D.: STD = STANDARD LENGTH PIN
- ALL DIMENSIONS ARE REFERENCE UNLESS OTHERWISE SPECIFIED WITH A TOLERANCE.
- PARTS ARE NOT TO BE MATED OR UNMATED WHILE CIRCUITS ARE LIVE.
- CORNER CORE-OUTS ARE OPTIONAL AND MAY OR MAY NOT BE PRESENT.
- FULL RIB INDICATES CIRCUIT NUMBER 1.
- DISCOLORATION IN THE BANDOLIER CARRIER AREA OF THE PIN IS INHERENT TO THE PLATING PROCESS AND IS DUE TO THE MASKING EFFECT OF THE CARRIER. THIS DISCOLORATION IS IN A NON-FUNCTIONAL AREA OF THE PIN AND WILL NOT AFFECT THE PERFORMANCE OF THE HEADER ASSEMBLY.
- PART CONFORMS TO CLASS "B" REQUIREMENTS OF COSMETIC SPECIFICATION PS-45499-002.
- TEXT SHOWN IS FOR REFERENCE ONLY. TEXT AND TEXT LOCATION MAY VARY DEPENDING ON PART NUMBER AND/OR TOOL

THIS DRAWING CONTAINS INFORMATION THAT IS PROPRIETARY TO MOLEX ELECTRONIC TECHNOLOGIES, LLC AND SHOULD NOT BE USED WITHOUT WRITTEN PERMISSION											
SYMBOLS		DIMENSION UNITS	SCALE	CURRENT REV DESC: ADD TAPE & REEL OPTION				molex			
▽ = 0	mm	4:1	EC NO: 626961				PRODUCT CUSTOMER DRAWING				
▽ = 0	GENERAL TOLERANCES (UNLESS SPECIFIED)		DRWN: DSTEIER 2019/09/30								
▽ = 0	ANGULAR TOL ± 0.5°		CHK'D: MKIPPER 2019/11/13				DOCUMENT NUMBER: 455860000-SD DOC TYPE: PSD DOC PART: 000 REVISION: A2				
▽ = 0	4 PLACES ±		APPR: FSMITH 2019/11/14								
▽ = 0	3 PLACES ±		INITIAL REVISION:				MATERIAL NUMBER: SEE TABLE CUSTOMER: GENERAL MARKET SHEET NUMBER: 1 OF 1				
▽ = 0	2 PLACES ± 0.25		DRWN: PKH 2017/09/07								
▽ = 0	1 PLACE ± 0.38		APPR: FSMITH 2017/09/22				DRAWING: C-SIZE SERIES: 45586				
▽ = 0	0 PLACES ±		DRAFT WHERE APPLICABLE MUST REMAIN WITHIN DIMENSIONS								