

**TRIPLE AND QUAD CHANNEL VIDEO AMPLIFIER EVALUATION BOARD**

**Evaluation board description**

The wide bandwidth of the ZXFV201/3 quad/triple channel video amplifiers necessitates some care in the layout of the printed circuit. For this reason Zetex has made available an Evaluation Board.

The evaluation board layout serves as a useful example for many applications, showing a practical implementation of the advice given below.

Figures 1, 2, 3 and 4 show the schematic and copper layout of a double-sided printed circuit board suitable for evaluation of the device in the laboratory.

BNC connector sockets allow connection to test instruments via 50Ω cables. The output circuit includes a resistor matching circuit to present a load of 150Ω to the amplifier (equivalent to a 75Ω back-terminated video line) and simultaneously provide a 50Ω output impedance.

The attenuation of this matching circuit is 15.45 dB. As the amplifier is configured for a voltage gain of 2, the overall gain is:

$$6 - 15.45 = -9.45\text{dB}$$

**PCB design**

A continuous ground plane is required under the device (except around its inverting input) to provide the shortest possible ground return paths for signals and power supply filtering.

A double-sided or multi-layer PCB construction is required, with plated-through via holes providing closely spaced low-inductance connections from some components to the continuous ground plane (some of these holes are not visible in the figures for the Evaluation Board - artworks and NC drill output can be provided if required).

**Power supply filtering**

For the power supply filtering, low inductance surface mount capacitors are normally required. It has been found that very good RF decoupling is provided on each supply using a 1000pF NPO size 0805 or smaller ceramic surface mount capacitor, closest to the device pin, with an adjacent 0.1μF X7R capacitor. Other configurations are possible and it may be found that a single 0.01μF X7R capacitor on each supply gives good results. However this should be supported by larger decoupling capacitors elsewhere on the printed circuit board. Values of 1 to 10 μF are recommended particularly where the voltage regulators are located more than a few inches from the device. These larger capacitors are recommended to be solid tantalum electrolytic or ceramic types.

A parts list is provided below.

**Evaluation board parts list**

QTY	Cct Ref	Value	Description
1			Printed circuit board ZDB189
<b>Resistors, surface mount</b>			
3 <sup>(1)</sup> /4	R1 <sup>(2)</sup> R5 R12 R22	51R	Resistor chip
6 <sup>(1)</sup> /8	R2 <sup>(2)</sup> R3 <sup>(2)</sup> R6 R7 R9 R10 R15 R16	470R	Resistor chip
3 <sup>(1)</sup> /4	R4 <sup>(2)</sup> R8 R11 R21	130R	Resistor chip
3 <sup>(1)</sup> /4	R13 R18 <sup>(2)</sup> R19 R23	33R	Resistor chip
3 <sup>(1)</sup> /4	R14 R17 <sup>(2)</sup> R20 R24	24R	Resistor chip
<b>Capacitors, surface mount</b>			
2	C1,C2	100nF	Capacitor ceramic chip X7R
2	C3,C4	2.2μF	Capacitor ceramic chip X7R
-	C5-C8		NOT FITTED
<b>Integrated circuits</b>			
1	U1	ZXFV201 <sup>(3)</sup> /ZXFV203 <sup>(1)</sup>	
<b>Miscellaneous</b>			
8	J1-J8		Socket BNC, PCB square flange
1	J9		Terminal block, 3 way

**NOTES:**

- (1) Applies to ZXFV203EV only
- (2) Not present on ZXFV203EV
- (3) Applies to ZXFV201EV only

# ZXFV203EV ZXFV201EV

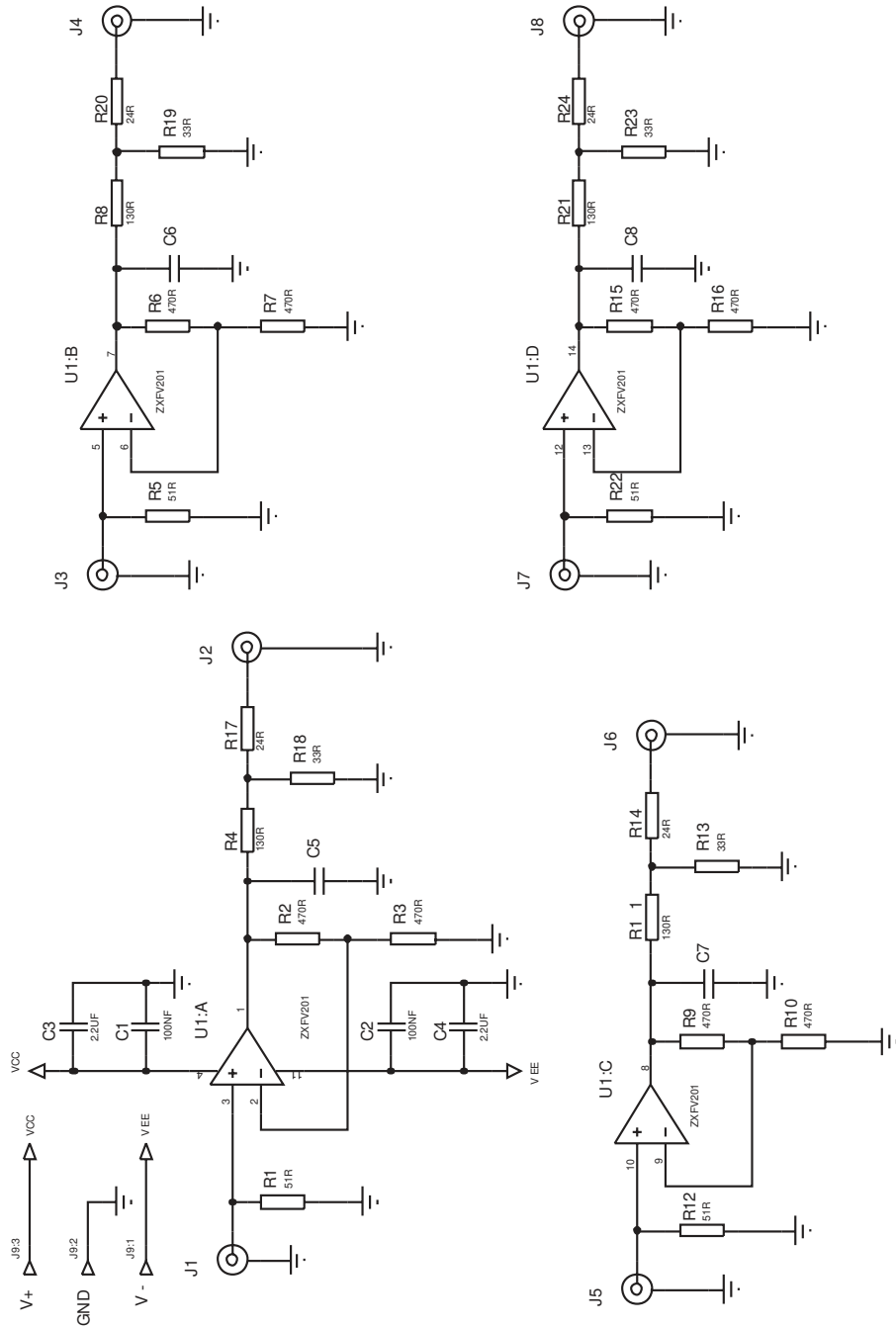

Figure 1 ZX-FV201EV/ZX-FV203EV schematic

# ZXFV203EV ZXFV201EV

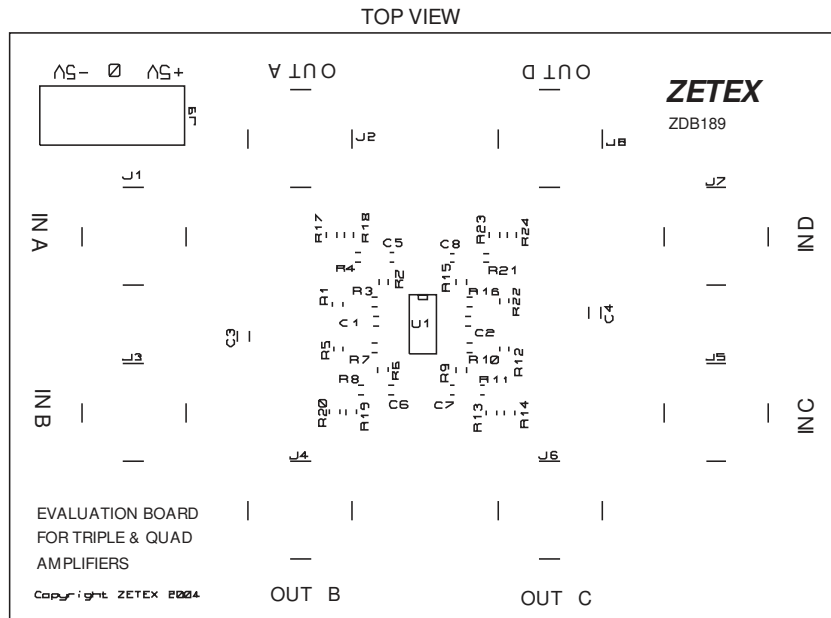

Figure 2 ZXFV201E/ZXFV203EV silkscreen

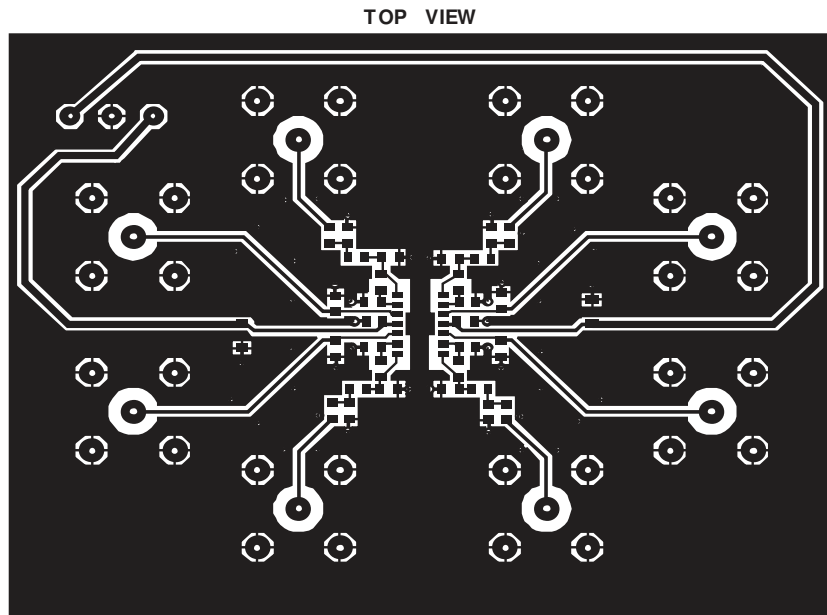

Figure 3 ZXFV201E/ZXFV203EV top copper

# ZXFV203EV ZXFV201EV

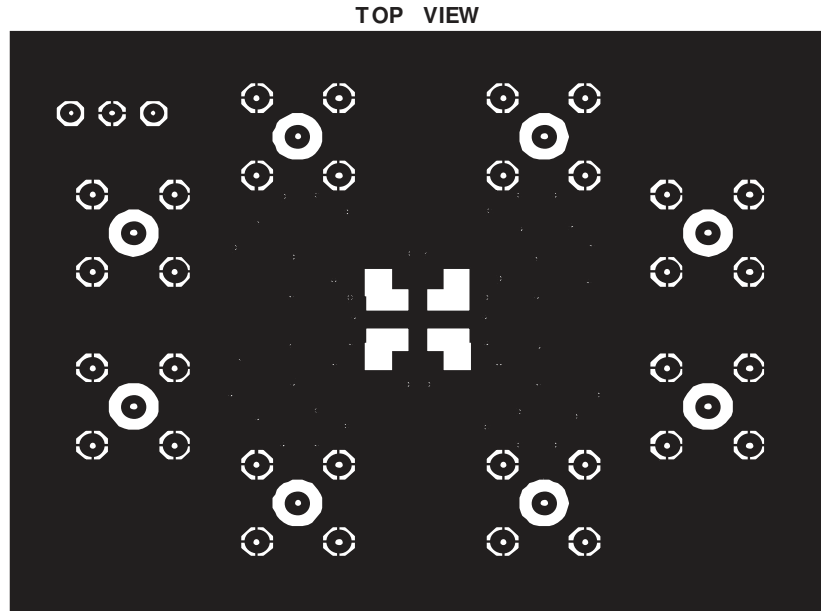

Figure 4 ZXFV201EV/ ZXFV203EV bottom copper

© Zetex plc 2004

Europe	Americas	Asia Pacific	Corporate Headquarters
Zetex GmbH Streitfeldstraße 19 D-81673 München Germany	Zetex Inc 700 Veterans Memorial Hwy Hauppauge, NY 11788 USA	Zetex (Asia) Ltd 3701-04 Metroplaza Tower 1 Hing Fong Road, Kwai Fong Hong Kong	Zetex plc Fields New Road, Chadderton Oldham, OL9 8NP United Kingdom
Telefon: (49) 89 45 49 49 0 Fax: (49) 89 45 49 49 49 europe.sales@zetex.com	Telephone: (1) 631 360 2222 Fax: (1) 631 360 8222 usa.sales@zetex.com	Telephone: (852) 26100 611 Fax: (852) 24250 494 asia.sales@zetex.com	Telephone (44) 161 622 4444 Fax: (44) 161 622 4446 hq@zetex.com

These offices are supported by agents and distributors in major countries world-wide.

This publication is issued to provide outline information only which (unless agreed by the Company in writing) may not be used, applied or reproduced for any purpose or form part of any order or contract or be regarded as a representation relating to the products or services concerned. The Company reserves the right to alter without notice the specification, design, price or conditions of supply of any product or service.

For the latest product information, log on to [www.zetex.com](http://www.zetex.com)