

MATERIAL

Glass-fibre reinforced polyamide based (PA) technopolymer, black colour, matte finish.

STANDARD EXECUTIONS

- **CWN-B:** brass boss, threaded blind hole.
- **CWN-FP:** brass boss, threaded pass-through hole.
- **CWN-p:** zinc-plated steel threaded stud with chamfered flat end as in UNI 947 : ISO 4753 (see Technical data on page A-10).

ERGONOMY AND DESIGN

The slightly convex marks on the wings offer a point where the fingers can be positioned.

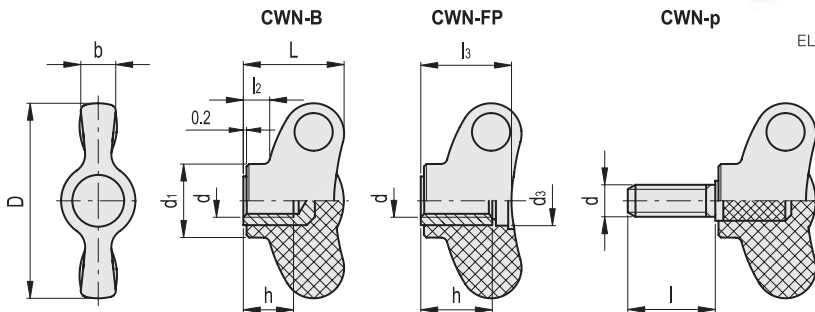

ELESA Original design

Conversion Table 1 mm = 0.039 inch	
D	
mm	inch
32	1.26
40	1.57

CWN-B

Code	Description	D	d6H	L	d1	l2	b	h	⚖️
8600	CWN.32 B-M4	32	M4	16.5	12	3.5	6	6	8
8601	CWN.32 B-M5	32	M5	16.5	12	3.5	6	6	7
8602	CWN.32 B-M6	32	M6	16.5	12	3.5	6	8	6
8651	CWN.40 B-M6	40	M6	21	13.5	4.5	6.5	12	12
8652	CWN.40 B-M8	40	M8	21	13.5	4.5	6.5	13	11

CWN-FP

Code	Description	D	d6H	L	d1	d3	l2	l3	b	h	⚖️
8605	CWN.32 FP-M5	32	M5	16.5	12	8	3.5	14.5	6	12	6
8606	CWN.32 FP-M6	32	M6	16.5	12	8	3.5	14.5	6	12	8
8656	CWN.40 FP-M8	40	M8	21	13.5	9.5	5	19	6.5	16	10

CWN-p

Code	Description	D	d6g	L	d1	l	l2	b	⚖️
8607	CWN.32 p-M4x10	32	M4	16.5	12	10	3.5	6	7
8608	CWN.32 p-M4x16	32	M4	16.5	12	16	3.5	6	8
8609	CWN.32 p-M5x10	32	M5	16.5	12	10	3.5	6	8
8610	CWN.32 p-M5x16	32	M5	16.5	12	16	3.5	6	9
8615	CWN.32 p-M5x20	32	M5	16.5	12	20	3.5	6	10
8611	CWN.32 p-M6x10	32	M6	16.5	12	10	3.5	6	8
8612	CWN.32 p-M6x16	32	M6	16.5	12	16	3.5	6	9
8613	CWN.32 p-M6x20	32	M6	16.5	12	20	3.5	6	11
8614	CWN.32 p-M6x25	32	M6	16.5	12	25	3.5	6	13
8616	CWN.32 p-M6x30	32	M6	16.5	12	30	3.5	6	10
8658	CWN.40 p-M6x16	40	M6	21	13.5	16	4.5	6.5	11
8662	CWN.40 p-M8x16	40	M8	21	13.5	16	4.5	6.5	12
8663	CWN.40 p-M8x20	40	M8	21	13.5	20	4.5	6.5	14
8664	CWN.40 p-M8x25	40	M8	21	13.5	25	4.5	6.5	17
8665	CWN.40 p-M8x30	40	M8	21	13.5	30	4.5	6.5	20

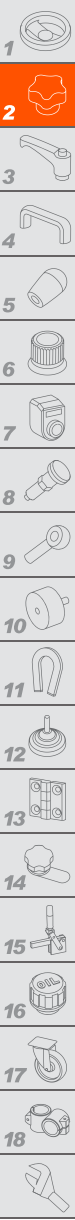

Clamping knobs