

MAX1605

30V Internal Switch LCD Bias Supply

General Description

The MAX1605 boost converter contains a 0.5A internal switch in a tiny 6-pin SOT23 package. The IC operates from a +2.4V to +5.5V supply voltage, but can boost battery voltages as low as 0.8V up to 30V at the output.

The MAX1605 uses a unique control scheme providing the highest efficiency over a wide range of load conditions. An internal 0.5A MOSFET reduces external component count, and a high switching frequency (up to 500kHz) allows for tiny surface-mount components. The current limit can be set to 500mA, 250mA, or 125mA, allowing the user to reduce the output ripple and component size in low-current applications.

Additional features include a low quiescent supply current and a shutdown mode to save power. The MAX1605 is ideal for small LCD panels with low current requirements, but can also be used in other applications. A MAX1605EVKIT evaluation kit (EV kit) is available to help speed up design time.

Applications

- LCD Bias Generators
- Cellular/Cordless Phones
- Palmtop Computers
- Personal Digital Assistants (PDAs)
- Organizers
- Handy Terminal

Pin Configuration

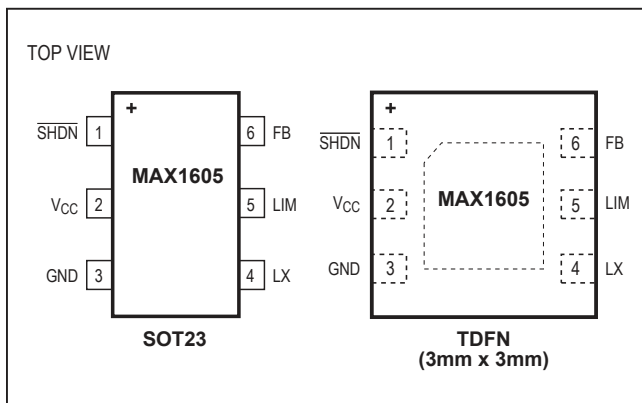

Features

- Adjustable Output Voltage up to 30V
- 20mA at 20V from a Single Li+ Battery
- 88% Efficiency
- Up to 500kHz Switching Frequency
- Selectable Inductor Current Limit (125mA, 250mA, or 500mA)
- 18µA Operating Supply Current
- 0.1µA Shutdown Current
- Available in Two Small Packages
 - 6-Pin TDFN
 - 6-Pin SOT23

Ordering Information

PART	TEMP RANGE	PIN-PACKAGE	SOT MARK
MAX1605EUT+T	-40°C to +85°C	6 SOT23-6	AAHP
MAX1605ETT+T	-40°C to +85°C	6 TDFN	ABW

Typical Operating Circuit

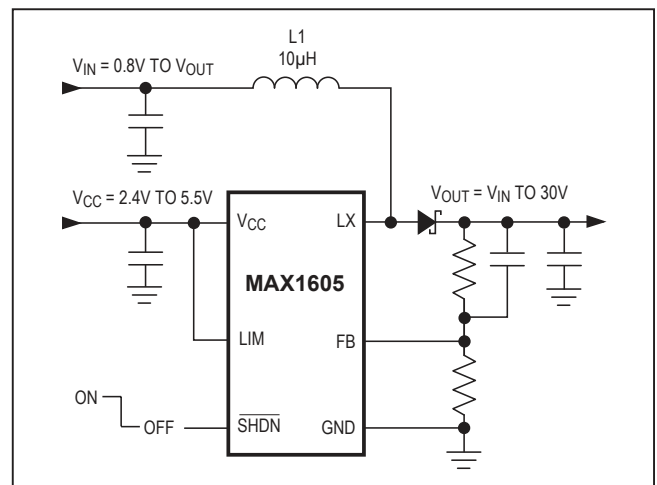

Absolute Maximum Ratings

V _{CC} , FB, LIM, $\overline{\text{SHDN}}$ to GND	-0.3V to +6V	Operating Temperature Range	-40°C to +85°C
LX to GND	-0.3V to +32V	Junction Temperature	+150°C
Continuous Power Dissipation (T _A = +70°C)		Storage Temperature Range	-65°C to +150°C
6-Pin SOT23 (derate 8.7mW/°C above +70°C)	696mW	Lead Temperature (soldering, 10s)	+300°C
6-Pin TDFN (derate 24.4mW/°C above +70°C)	1951mW		

Stresses beyond those listed under "Absolute Maximum Ratings" may cause permanent damage to the device. These are stress ratings only, and functional operation of the device at these or any other conditions beyond those indicated in the operational sections of the specifications is not implied. Exposure to absolute maximum rating conditions for extended periods may affect device reliability.

Electrical Characteristics

(V_{CC} = SHDN = 3.3V, T_A = 0°C to +85°C, unless otherwise noted. Typical values are at T_A = +25°C.) (Note 1)

PARAMETER	SYMBOL	CONDITIONS	MIN	TYP	MAX	UNITS
Supply Voltage	V _{CC}	(Note 2)	2.4		5.5	V
Inductor Input Voltage Range	V _{IN}	(Note 2)	0.8		V _{OUT}	V
V _{CC} Undervoltage Lockout	V _{UVLO}	V _{CC} falling, 50mV typical hysteresis	2.0	2.2	2.37	V
Quiescent Supply Current	I _{CC}	V _{FB} = 1.3V		18	35	μA
Shutdown Supply Current		$\overline{\text{SHDN}}$ = GND		0.1	1	μA
V _{CC} Line Regulation	ΔV _{LNR}	V _{OUT} = 18V, I _{LOAD} = 1mA, V _{IN} = 5V, V _{CC} = V _{LIM} = 2.4V to 5.5V		0.1		%/V
V _{IN} Line Regulation	ΔV _{LNR}	V _{OUT} = 18V, I _{LOAD} = 1mA, V _{CC} = V _{LIM} = 5V, V _{IN} = 2.4V to 12V		0.15		%/V
Load Regulation	ΔV _{LDR}	V _{OUT} = 18V, V _{CC} = V _{IN} = V _{LIM} = 5V, I _{LOAD} = 0mA to 20mA		0.1		%/mA
Efficiency		L1 = 100μH, V _{IN} = 3.6V, I _{LOAD} = 10mA		88		%
Feedback Set Point	V _{FB}		1.225	1.25	1.275	V
Feedback Input Bias Current	I _{FB}	V _{FB} = 1.3V		5	100	nA
LX						
LX Voltage Range	V _{LX}				30.5	V
LX Switch Current Limit	I _{LX(MAX)}	LIM = V _{CC}	0.40	0.50	0.56	A
		LIM = floating	0.20	0.25	0.285	
		LIM = GND	0.10	0.125	0.15	
LX On-Resistance	R _{LX}	V _{CC} = 5V, I _{LX} = 100mA	0.8			Ω
		V _{CC} = 3.3V, I _{LX} = 100mA	1	2		
LX Leakage Current		V _{LX} = 30.5V			2	μA
Maximum LX On-Time	t _{ON}		10	13	16	μs
Minimum LX Off-Time	t _{OFF}	V _{FB} > 1.1V	0.8	1.0	1.2	μs
		V _{FB} < 0.8V (soft-start)	3.9	5.0	6.0	

Electrical Characteristics (continued)

($V_{CC} = \overline{\text{SHDN}} = 3.3\text{V}$, $T_A = 0^\circ\text{C}$ to $+85^\circ\text{C}$, unless otherwise noted. Typical values are at $T_A = +25^\circ\text{C}$.) (Note 1)

PARAMETER	SYMBOL	CONDITIONS	MIN	TYP	MAX	UNITS
CONTROL INPUTS						
$\overline{\text{SHDN}}$ Input Threshold	V_{IH}	$2.4\text{V} \leq V_{CC} \leq 5.5\text{V}$	0.8 x V_{CC}		V	
	V_{IL}	$2.4\text{V} \leq V_{CC} \leq 5.5\text{V}$	0.2 x V_{CC}			
$\overline{\text{SHDN}}$ Input Bias Current	$I_{\overline{\text{SHDN}}}$	$V_{CC} = 5.5\text{V}$, $V_{\overline{\text{SHDN}}} = 0$ to 5.5V	-1		1	μA
LIM Input Low Level		$2.4\text{V} \leq V_{CC} \leq 5.5\text{V}$			0.4	V
LIM Input Float Level		$2.4\text{V} \leq V_{CC} \leq 5.5\text{V}$, $I_{LIM} = \pm 0.5\mu\text{A}$	$(V_{CC}/2) - 0.2\text{V}$		$(V_{CC}/2) + 0.2\text{V}$	V
LIM Input High Level		$2.4\text{V} \leq V_{CC} \leq 5.5\text{V}$	$V_{CC} - 0.4\text{V}$			V
LIM Input Bias Current	I_{LIM}	$\overline{\text{SHDN}} = V_{CC}$, LIM = GND or V_{CC}	-2		2	μA
		$\overline{\text{SHDN}} = \text{GND}$		0.1	1	

Electrical Characteristics

($V_{CC} = \overline{\text{SHDN}} = 3.3\text{V}$, $T_A = -40^\circ\text{C}$ to $+85^\circ\text{C}$, unless otherwise noted.) (Note 1)

PARAMETER	SYMBOL	CONDITIONS	MIN	MAX	UNITS	
Supply Voltage	V_{CC}	(Note 2)	2.4	5.5	V	
Inductor Input Voltage Range	V_{IN}	(Note 2)	0.8	V_{OUT}	V	
V_{CC} Undervoltage Lockout	V_{UVLO}	V_{CC} falling, 50mV typical hysteresis	2.0	2.37	V	
Quiescent Supply Current	I_{CC}	$V_{FB} = 1.3\text{V}$		35	μA	
Shutdown Supply Current		$\overline{\text{SHDN}} = \text{GND}$		1	μA	
Feedback Set Point	V_{FB}		1.215	1.285	V	
Feedback Input Bias Current	I_{FB}	$V_{FB} = 1.3\text{V}$		100	nA	
LX						
LX Voltage Range	V_{LX}			30.5	V	
LX Switch Current Limit	$I_{LX(\text{MAX})}$	LIM = V_{CC}	0.35	0.58	A	
		LIM = floating	0.18	0.30		
		LIM = GND	0.08	0.17		
LX On-Resistance	R_{LX}	$V_{CC} = 3.3\text{V}$, $I_{LX} = 100\text{mA}$		2	Ω	
LX Leakage Current		$V_{LX} = 30.5\text{V}$		2	μA	
Maximum LX On-Time	t_{ON}		9	17	μs	
Minimum LX Off-Time	t_{OFF}	$V_{FB} > 1.1\text{V}$	0.75	1.25	μs	
		$V_{FB} < 0.8\text{V}$	3.8	6.0		
CONTROL INPUTS						
$\overline{\text{SHDN}}$ Input Threshold	V_{IH}	$2.4\text{V} \leq V_{CC} \leq 5.5\text{V}$	0.8 x V_{CC}		V	
	V_{IL}	$2.4\text{V} \leq V_{CC} \leq 5.5\text{V}$	0.2 x V_{CC}			
$\overline{\text{SHDN}}$ Input Bias Current	$I_{\overline{\text{SHDN}}}$	$V_{CC} = 5.5\text{V}$, $V_{\overline{\text{SHDN}}} = 0$ to 5.5V	-1		1	μA

Electrical Characteristics (continued)

($V_{CC} = \overline{SHDN} = 3.3V$, $T_A = -40^{\circ}C$ to $+85^{\circ}C$, unless otherwise noted.) (Note 1)

PARAMETER	SYMBOL	CONDITIONS	MIN	MAX	UNITS
LIM Input Low Level		$2.4V \leq V_{CC} \leq 5.5V$		0.4	V
LIM Input Float Level		$2.4V \leq V_{CC} \leq 5.5V$, $I_{LIM} = \pm 0.5\mu A$	$(V_{CC} / 2) - 0.25V$	$(V_{CC} / 2) + 0.25V$	V
LIM Input High Level		$2.4V \leq V_{CC} \leq 5.5V$	$V_{CC} - 0.4V$		V
LIM Input Bias Current	I_{LIM}	$\overline{SHDN} = V_{CC}$, LIM = GND or V_{CC}	-2	2	μA
		$\overline{SHDN} = GND$		1	

Note 1: All devices are 100% tested at $T_A = +25^{\circ}C$. All limits over the temperature range are guaranteed by design.

Note 2: The MAX1605 requires a supply voltage between +2.4V and +5.5V; however, the input voltage used to power the inductor can vary from +0.8V to V_{OUT} .

Typical Operating Characteristics

($V_{CC} = 3.3V$, $V_{IN} = 3.6V$, $L1 = 10\mu H$, $\overline{SHDN} = LIM = V_{CC}$, $V_{OUT(NOM)} = 18V$ (Figure 3), $T_A = +25^{\circ}C$, unless otherwise noted.)

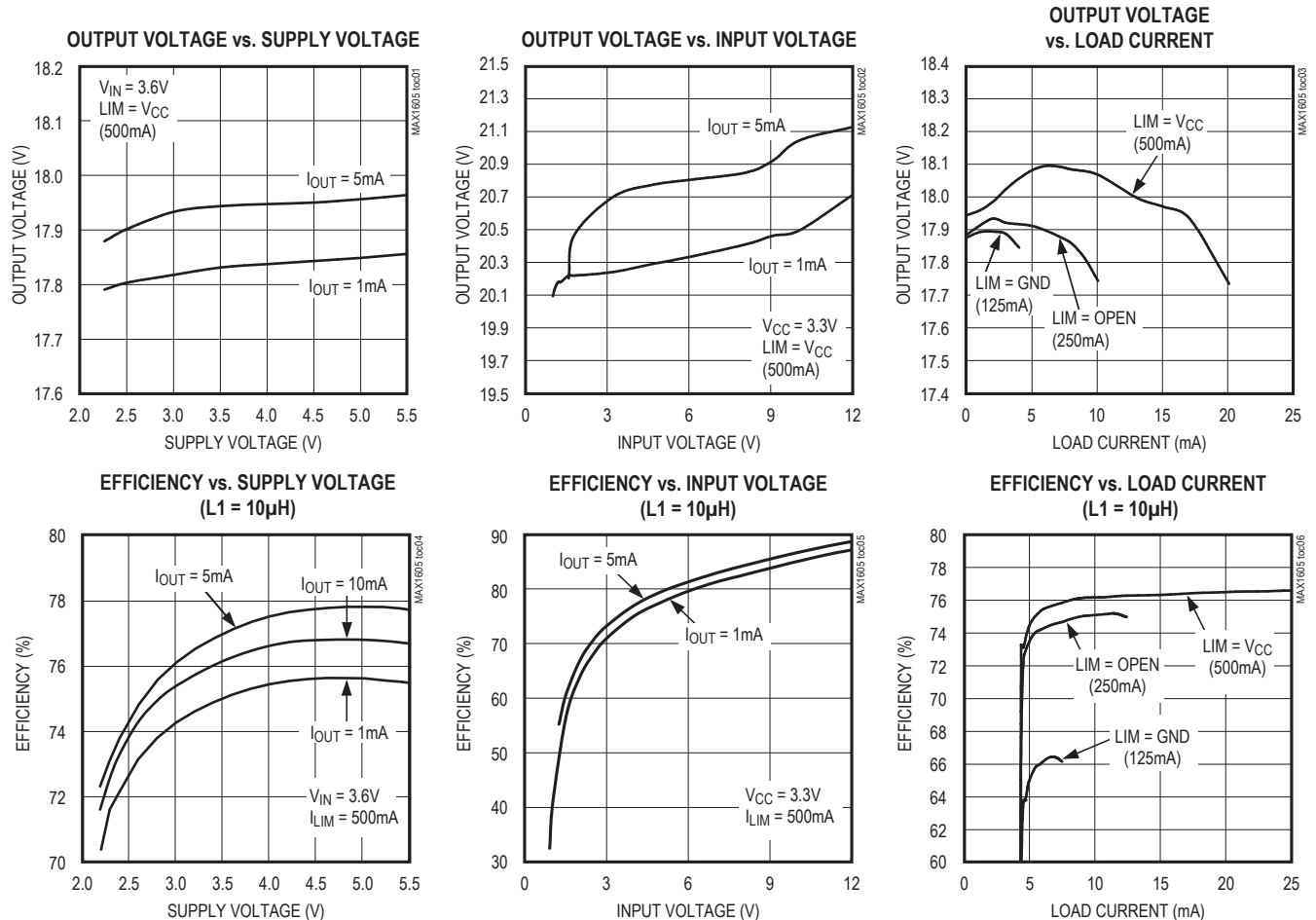

Electrical Characteristics (continued)

($V_{CC} = 3.3V$, $V_{IN} = 3.6V$, $L1 = 10\mu H$, $\overline{SHDN} = LIM = V_{CC}$, $V_{OUT(NOM)} = 18V$ (Figure 3), $T_A = +25^\circ C$, unless otherwise noted.)

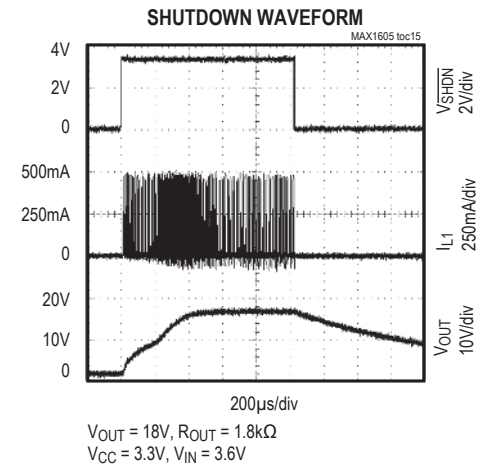
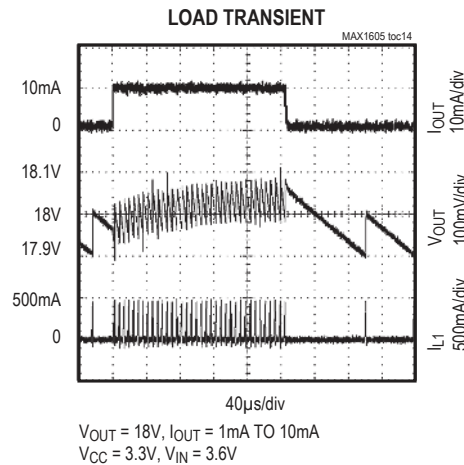
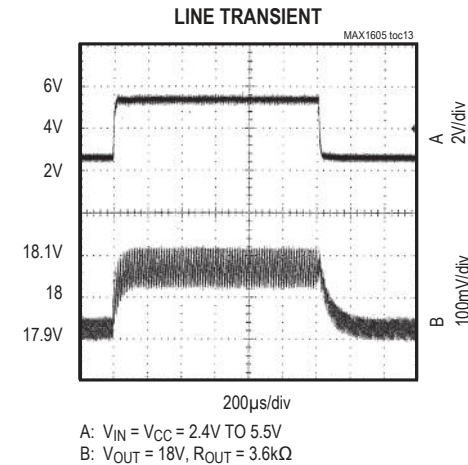
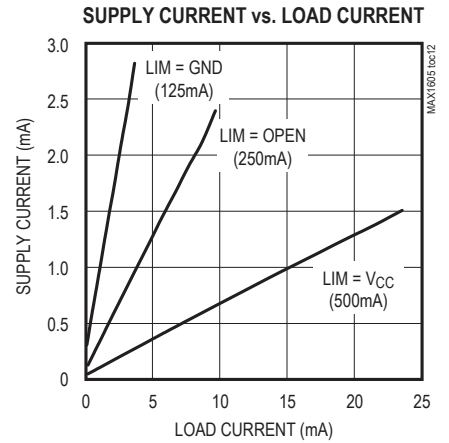
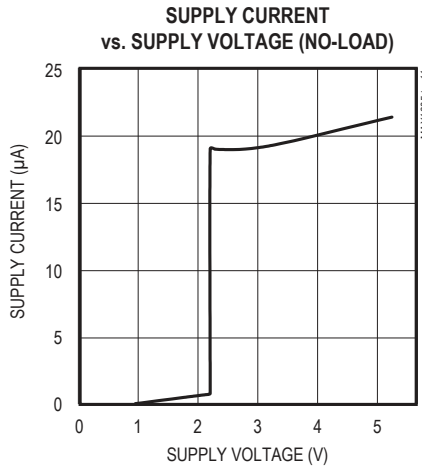
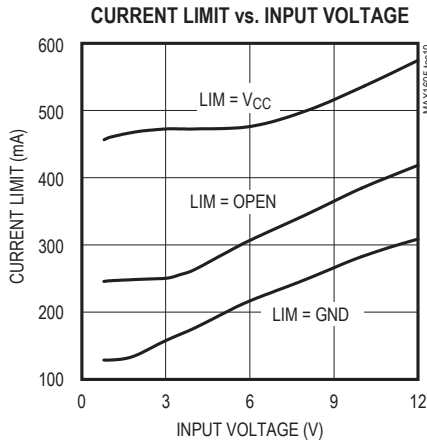
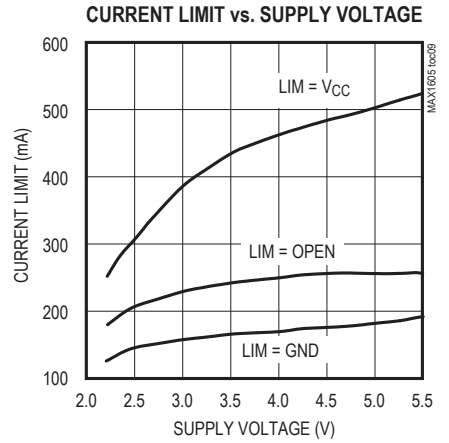
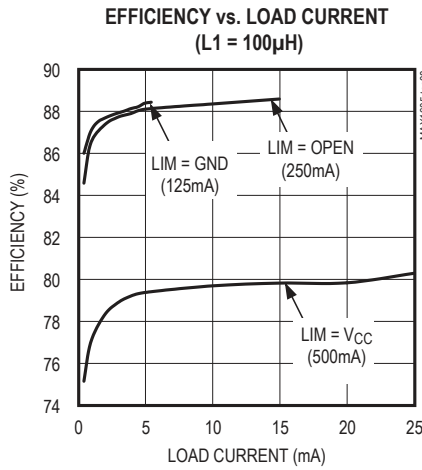
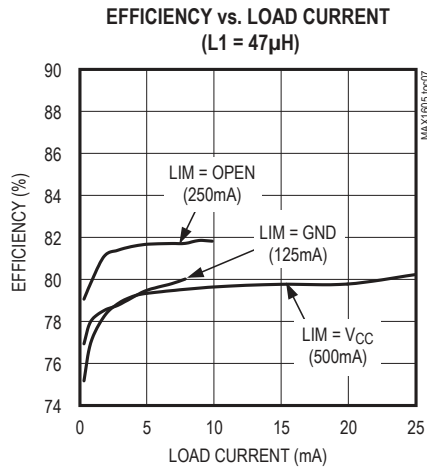

Pin Description

PIN	NAME	FUNCTION
1	$\overline{\text{SHDN}}$	Active-Low Shutdown Input. A logic low shuts down the device and reduces the supply current to 0.1 μA . Connect SHDN to V_{CC} for normal operation.
2	V_{CC}	IC Supply Voltage (+2.4V to +5.5V). Bypass V_{CC} to GND with a 0.1 μF or greater capacitor.
3	GND	Ground
4	LX	Inductor Connection. The drain of an internal 30V N-channel MOSFET. LX is high impedance in shutdown.
5	LIM	Inductor Current Limit Selection. Connect LIM to V_{CC} for 500mA, leave LIM floating for 250mA, or connect LIM to GND for 125mA.
6	FB	Feedback Input. Connect to a resistive-divider network between the output (V_{OUT}) and FB to set the output voltage between V_{IN} and 30V. The feedback threshold is 1.25V.

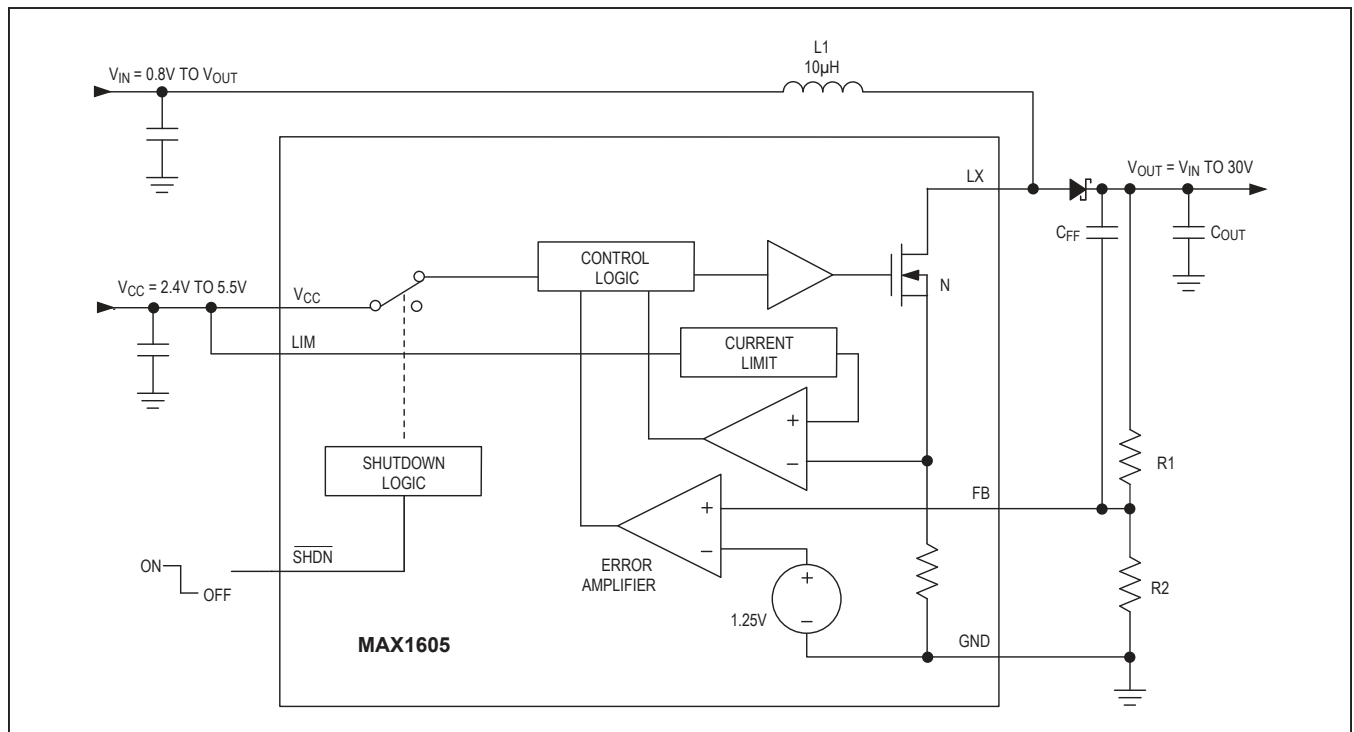

Figure 1. Functional Diagram

Detailed Description

The MAX1605 compact, step-up DC-DC converter operates from a +2.4V to +5.5V supply. Consuming only 18 μA of supply current, the device includes an internal switching MOSFET with 1 Ω on-resistance and selectable current limit (Figure 1). During startup, the MAX1605 extends the minimum off-time, limiting initial surge current. The MAX1605 also features a shutdown mode.

Control Scheme

The MAX1605 features a minimum off-time, current-limited control scheme. The duty cycle is governed by a pair of one-shots that set a minimum off-time and a maximum on-time. The switching frequency can be up to 500kHz and depends upon the load and input voltage. The peak current limit of the internal N-channel MOSFET is pin selectable and may be set at 125mA, 250mA, or 500mA (Figure 2).

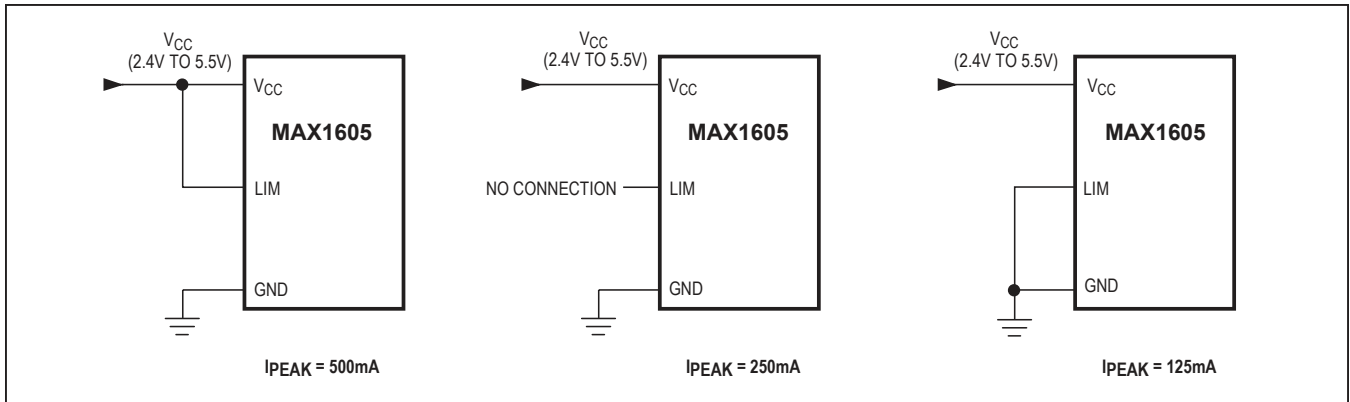

Figure 2. Setting the Peak Inductor Current Limit

Setting the Output Voltage (FB)

Adjust the output voltage by connecting a voltage-divider from the output (V_{OUT}) to FB (Figure 3). Select R2 between 10kΩ to 200kΩ. Calculate R1 with the following equation:

$$R1 = R2 [(V_{OUT} / V_{FB}) - 1]$$

where V_{FB} = 1.25V and V_{OUT} may range from V_{IN} to 30V. The input bias current of FB has a maximum value of 100nA, which allows large-value resistors to be used. For less than 1% error, the current through R2 should be greater than 100 times the feedback input bias current (I_{FB}).

Current Limit Select Pin (LIM)

The MAX1605 allows a selectable inductor current limit of 125mA, 250mA, or 500mA (Figure 2). This allows flexibility in designing for higher current applications or for smaller, compact designs. The lower current limit allows the use of a physically smaller inductor in space-sensitive, low-power applications. Connect LIM to V_{CC} for 500mA, leave floating for 250mA, or connect to GND for 125mA.

Shutdown ($\overline{\text{SHDN}}$)

Pull $\overline{\text{SHDN}}$ low to enter shutdown. During shutdown, the supply current drops to 0.1μA and LX enters a high-impedance state. However, the output remains connected to the input through the inductor and output rectifier, holding the output voltage to one diode drop below V_{IN} when the MAX1605 is shut down. The capacitance and load at OUT determine the rate at which V_{OUT} decays. $\overline{\text{SHDN}}$ can be pulled as high as 6V, regardless of the input and output voltages.

Separate/Same Power for L1 and V_{CC}

Separate voltage sources can supply the inductor (V_{IN}) and the IC (V_{CC}). This allows operation from low-voltage batteries as well as high-voltage sources (0.8V to 30V) because chip bias is provided by a logic supply (2.4V to 5.5V), while the output power is sourced directly from the battery to L1. Conversely, V_{IN} and V_{CC} can also be supplied from one supply if it remains within V_{CC}'s operating limits (+2.4V to +5.5V).

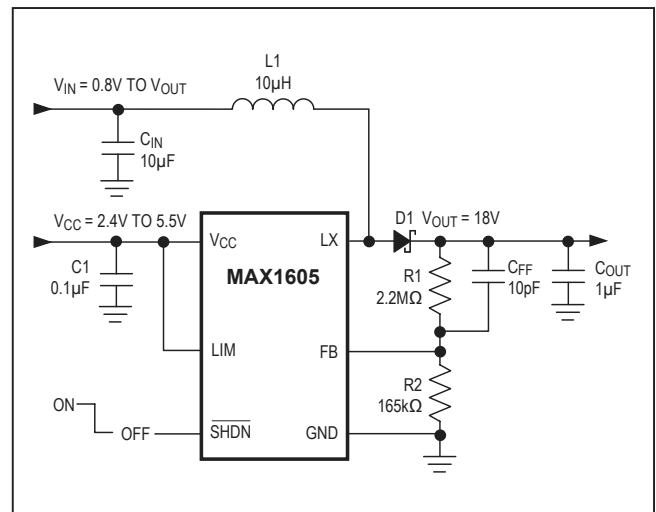

Figure 3. Typical Application Circuit

Design Procedure

Inductor Selection

Smaller inductance values typically offer smaller physical size for a given series resistance or saturation current. Circuits using larger inductance values may start up at lower input voltages and exhibit less ripple, but also provide reduced output power. This occurs when the inductance is sufficiently large to prevent the maximum current limit from being reached before the maximum on-time expires. The inductor's saturation current rating should be greater than the peak switching current. However, it is generally acceptable to bias the inductor into saturation by as much as 20%, although this will slightly reduce efficiency.

Picking the Current Limit

The peak LX current limit ($I_{LX(MAX)}$) required for the application may be calculated from the following equation:

$$I_{LX(MAX)} \geq \frac{V_{OUT} \times I_{OUT(MAX)}}{V_{IN(MIN)}} + \frac{(V_{OUT} - V_{IN(MIN)}) \times t_{OFF(MIN)}}{2 \times L}$$

where $t_{OFF(MIN)} = 0.8\mu s$, and $V_{IN(MIN)}$ is the minimum voltage used to supply the inductor. The set current limit must be greater than this calculated value. Select the appropriate current limit by connecting LIM to V_{CC} , GND, or leaving it unconnected (see the *Current Limit Select Pin (LIM)* section and Figure 2).

Diode Selection

The high maximum switching frequency of 500kHz requires a high-speed rectifier. Schottky diodes, such as the Motorola MBRS0530 or the Nihon EP05Q03L, are recommended. To maintain high efficiency, the average current rating of the Schottky diode should be greater than the peak switching current. Choose a reverse breakdown voltage greater than the output voltage.

Output Filter Capacitor

For most applications, use a small ceramic surface-mount output capacitor, 1 μF or greater. For small ceramic capacitors, the output ripple voltage is dominated by the capacitance value. If tantalum or electrolytic capacitors are used, the higher ESR increases the output ripple voltage. Decreasing the ESR reduces the output ripple voltage and the peak-to-peak transient voltage.

Surface-mount capacitors are generally preferred because they lack the inductance and resistance of their through-hole equivalents.

Input Bypass Capacitor

Two inputs, V_{CC} and V_{IN} , require bypass capacitors. Bypass V_{CC} with a 0.1 μF ceramic capacitor as close to the IC as possible. The input supplies high currents to the inductor and requires local bulk bypassing close to the inductor. A 10 μF low-ESR surface-mount capacitor is sufficient for most applications.

PC Board Layout and Grounding

Careful printed circuit layout is important for minimizing ground bounce and noise. Keep the MAX1605's ground pin and the ground leads of the input and output capacitors less than 0.2in (5mm) apart. In addition, keep all connections to FB and LX as short as possible. In particular, when using external feedback resistors, locate them as close to FB as possible. To minimize output voltage ripple, and to maximize output power and efficiency, use a ground plane and solder GND directly to the ground plane. Refer to the MAX1605EVKIT evaluation kit for a layout example.

Applications Information

Negative Voltage for LCD Bias

The MAX1605 can also generate a negative output by adding a diode-capacitor charge-pump circuit (D1, D2, and C3) to the LX pin as shown in Figure 4. Feedback is still connected to the positive output, which is not loaded, allowing a very small capacitor value at C4. For best stability and lowest ripple, the time constant of the R1-R2 series combination and C4 should be near or less than that of C2 and the effective load resistance. Output load regulation of the negative output is somewhat looser than with the standard positive output circuit, and may rise at very light loads due to coupling through the capacitance of D2. If this is objectionable, reduce the resistance of R1 and R2, while maintaining their ratio, to effectively preload the output with a few hundred microamps. This is why the R1-R2 values shown in Figure 3 are about 10-times lower than typical values used for a positive-output design. When loaded, the negative output voltage will be slightly lower (closer to ground by approximately a diode forward voltage) than the inverse of the voltage on C4.

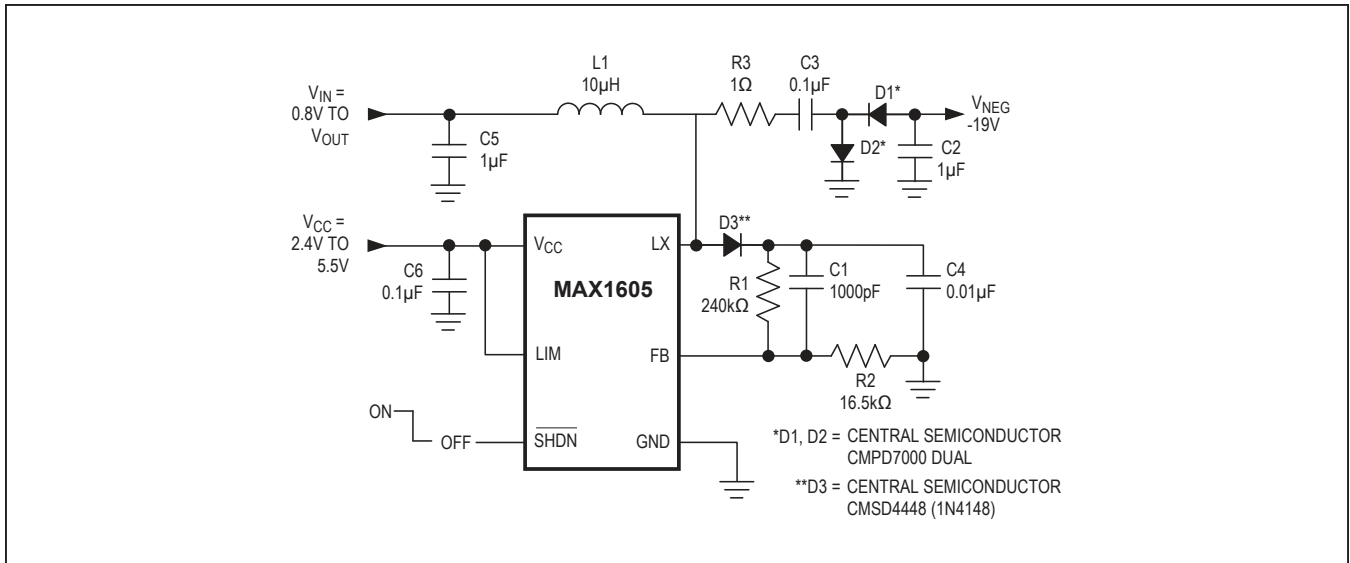

Figure 4. Negative Voltage for LCD Bias

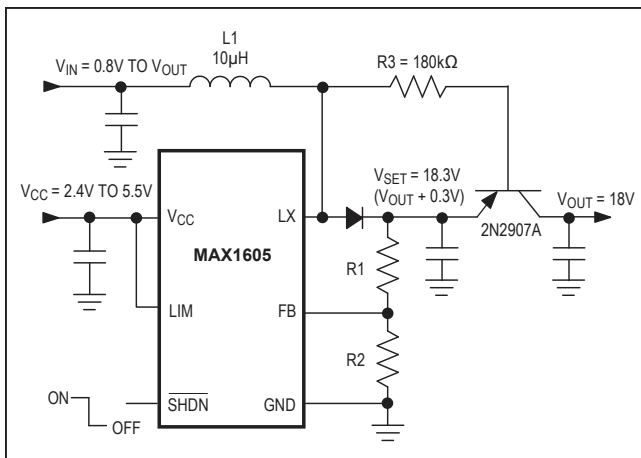

Figure 5. Output Disconnected in Shutdown

Chip Information

TRANSISTOR COUNT: 2329

Output Disconnected in Shutdown

When the MAX1605 is shut down, the output remains connected to the input (Figure 3), so the output voltage falls to approximately $V_{IN} - 0.6V$ (the input voltage minus a diode drop). For applications that require output isolation during shutdown, add an external PNP transistor as shown in Figure 4. When the MAX1605 is active, the voltage set at the transistor's emitter exceeds the input voltage, forcing the transistor into the saturation region. When shut down, the input voltage exceeds the emitter voltage so the inactive transistor provides high-impedance isolation between the input and output. Efficiency will be slightly degraded due to the PNP transistor saturation voltage and base current.

Package Information

For the latest package outline information and land patterns (footprints), go to www.maximintegrated.com/packages. Note that a "+", "#", or "-" in the package code indicates RoHS status only. Package drawings may show a different suffix character, but the drawing pertains to the package regardless of RoHS status.

PACKAGE TYPE	PACKAGE CODE	OUTLINE NO.	LAND PATTERN NO.
6 SOT23	U6F+6	21-0058	90-0175
6 TDFN	T633+2	21-0137	90-0058

Revision History

REVISION NUMBER	REVISION DATE	DESCRIPTION	PAGES CHANGED
2	8/18	Updated <i>Ordering Information</i> and <i>Packaging Information</i>	1, 10

For pricing, delivery, and ordering information, please visit Maxim Integrated's online storefront at <https://www.maximintegrated.com/en/storefront/storefront.html>.

Maxim Integrated cannot assume responsibility for use of any circuitry other than circuitry entirely embodied in a Maxim Integrated product. No circuit patent licenses are implied. Maxim Integrated reserves the right to change the circuitry and specifications without notice at any time. The parametric values (min and max limits) shown in the Electrical Characteristics table are guaranteed. Other parametric values quoted in this data sheet are provided for guidance.