

ISL31483E, ISL31485E

Fault Protected, Extended CMR, RS-485/RS-422 Transceivers with Cable Invert

FN7638
Rev 4.00
May 13, 2015

The [ISL31483E](#) and [ISL31485E](#) are fault protected, 5V powered differential transceivers that exceed the RS-485 and RS-422 standards for balanced communication. The RS-485 transceiver pins (driver outputs and receiver inputs) are fault protected up to $\pm 60V$. Additionally, the extended common mode range allows these transceivers to operate in environments with common mode voltages up to $\pm 25V$ ($>2x$ the RS-485 requirement), making this fault protected RS-485 family one of the most robust on the market.

Transmitters deliver an exceptional 2.5V (typical) differential output voltage into the RS-485 specified 54Ω load. This yields better noise immunity than standard RS-485 ICs, or allows up to six 120Ω terminations in star network topologies.

Receiver (Rx) inputs feature a "Full Fail-Safe" design, which ensures a logic high Rx output if Rx inputs are floating, shorted, or on a terminated but undriven (idle) bus.

The ISL31483E and ISL31485E include cable invert functions that reverse the polarity of the Rx and/or Tx bus pins in case the cable is misconnected. Unlike competing devices, Rx full fail-safe operation is maintained even when the Rx input polarity is switched.

Features

- Fault protected RS-485 bus pins up to $\pm 60V$
- Extended common mode range. $\pm 25V$
More than twice the range required for RS-485
- Cable invert pins
corrects for reversed cable connections while maintaining Rx full fail-safe functionality
- Full fail-safe (open, short, terminated) RS-485 receivers
- 1/4 unit load (UL) for up to 128 devices on the bus
- High Rx I_{OL} for opto-couplers in isolated designs
- Hot plug circuitry - Tx and Rx outputs remain three-state during power-up/power-down
- Slew rate limited RS-485 data rate 1Mbps
- Low quiescent supply current. 2.3mA
- Ultra low shutdown supply current. 10 μA

Applications

- Utility meters/automated meter reading systems
- High node count RS-485 systems
- PROFIBUS™ and RS-485 based field bus networks and factory automation
- Security camera networks
- Building lighting and environmental control systems
- Industrial/process control networks

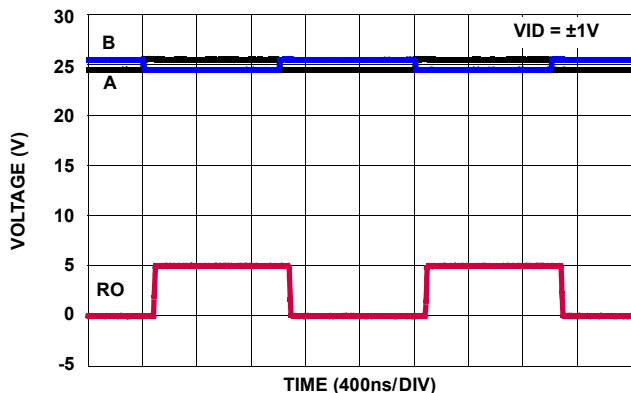

FIGURE 1. EXCEPTIONAL Rx OPERATES AT 1Mbps EVEN WITH $\pm 25V$ COMMON MODE VOLTAGE

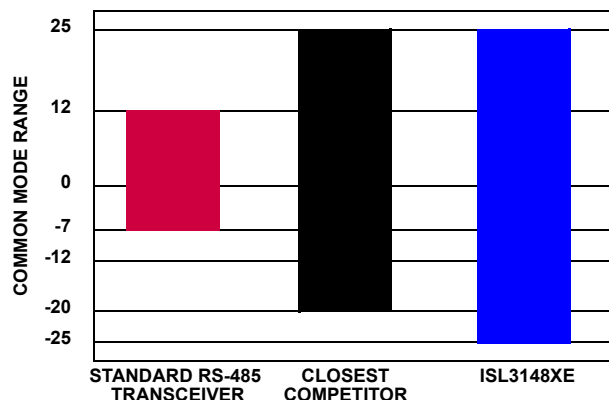

FIGURE 2. TRANSCEIVERS DELIVER SUPERIOR COMMON MODE RANGE vs STANDARD RS-485 DEVICES

Table of Contents

Ordering Information	3
Pin Configurations	4
Pin Descriptions	4
Truth Tables	5
Typical Operating Circuits	5
Absolute Maximum Ratings	6
Thermal Information	6
Recommended Operating Conditions	6
Electrical Specifications	6
Test Circuits and Waveforms	9
Application Information	11
Receiver (Rx) Features	11
Driver (Tx) Features	11
High Overvoltage (Fault) Protection Increases Ruggedness	11
Widest Common Mode Voltage (CMV) Tolerance Improves Operating Range	11
Cable Invert (Polarity Reversal) Function	11
High VOD Improves Noise Immunity and Flexibility	12
Hot Plug Function	12
Data Rate, Cables and Terminations	12
Built-in Driver Overload Protection	12
Low Power Shutdown Mode	13
Typical Performance Curves	14
Die Characteristics	15
Revision History	16
About Intersil	16
Package Outline Drawing	17
M14.15	17
M8.15	18

TABLE 1. SUMMARY OF FEATURES

PART NUMBER	HALF/FULL DUPLEX	DATA RATE (Mbps)	SLEW-RATE LIMITED?	EN PINS?	HOT PLUG	POLARITY REVERSAL PINS?	QUIESCENT I _{CC} (mA)	LOW POWER SHDN?	PIN COUNT
ISL31483E	Full	1	Yes	Yes	Yes	Yes	2.3	Yes	14
ISL31485E	Half	1	Yes	Tx Only	Yes	Yes	2.3	No	8

Ordering Information

PART NUMBER (Notes 1, 2, 3)	PART MARKING	TEMP. RANGE (°C)	PACKAGE (RoHS Compliant)	PKG. DWG. #
ISL31483EIBZ	ISL31483 EIBZ	-40 to +85	14 Ld SOIC	M14.15
ISL31485EIBZ	31485 EIBZ	-40 to +85	8 Ld SOIC	M8.15

NOTES:

1. Add "-T*" suffix for tape and reel. Please refer to [TB347](#) for details on reel specifications.
2. These Intersil Pb-free plastic packaged products employ special Pb-free material sets, molding compounds/die attach materials, and 100% matte tin plate plus anneal (e3 termination finish, which is RoHS compliant and compatible with both SnPb and Pb-free soldering operations). Intersil Pb-free products are MSL classified at Pb-free peak reflow temperatures that meet or exceed the Pb-free requirements of IPC/JEDEC J STD-020.
3. For Moisture Sensitivity Level (MSL), please see product information page for [ISL31483E](#), [ISL31485E](#). For more information on MSL, please see tech brief [TB363](#)

Pin Configurations

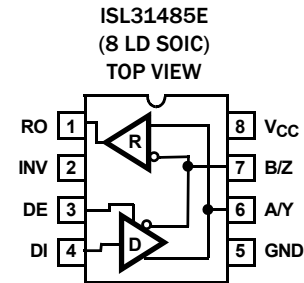
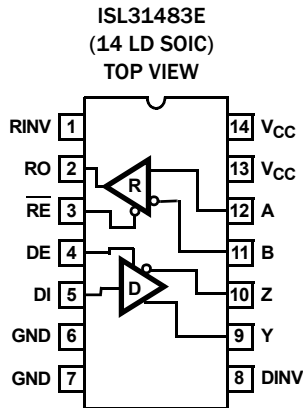

Pin Descriptions

PIN NAME	PIN # ISL31483E	PIN # ISL31485E	DESCRIPTION
RO	2	1	Receiver output. If INV or RINV is low, then: If $A - B \geq -10\text{mV}$, RO is high; if $A - B \leq -200\text{mV}$, RO is low. If INV or RINV is high, then: If $B - A \geq -10\text{mV}$, RO is high; if $B - A \leq -200\text{mV}$, RO is low. In all cases, RO = High if A and B are unconnected (floating), or shorted together, or connected to an undriven, terminated bus (i.e., Rx is always failsafe open, shorted and idle, even if polarity is inverted).
$\overline{\text{RE}}$	3	-	Receiver output enable. RO is enabled when $\overline{\text{RE}}$ is low; RO is high impedance when $\overline{\text{RE}}$ is high. Internally pulled low.
DE	4	3	Driver output enable. The driver outputs, Y and Z, are enabled by bringing DE high and they are high impedance when DE is low. Internally pulled high to V_{CC} .
DI	5	4	Driver input. If INV or DINV is low, a low on DI forces output Y low and output Z high, while a high on DI forces output Y high and output Z low. The output states relative to DI invert if INV or DINV is high.
GND	6, 7	5	Ground connection.
A/Y	-	6	$\pm 60\text{V}$ Fault Protected RS-485/RS-422 level I/O pin. If INV is low, A/Y is the non-inverting receiver input and non-inverting driver output. If INV is high, A/Y is the inverting receiver input and the inverting driver output. Pin is an input if DE = 0; pin is an output if DE = 1.
B/Z	-	7	$\pm 60\text{V}$ Fault Protected RS-485/RS-422 level I/O pin. If INV is low, B/Z is the inverting receiver input and inverting driver output. If INV is high, B/Z is the non-inverting receiver input and the non-inverting driver output. Pin is an input if DE = 0; pin is an output if DE = 1.
A	12	-	$\pm 60\text{V}$ Fault Protected RS-485/RS-422 level input. If RINV is low, then A is the non-inverting receiver input. If RINV is high, then A is the inverting receiver input.
B	11	-	$\pm 60\text{V}$ Fault Protected RS-485/RS-422 level input. If RINV is low, then B is the inverting receiver input. If RINV is high, then B is the non-inverting receiver input.
Y	9	-	$\pm 60\text{V}$ Fault Protected RS-485/RS-422 level output. If DINV is low, then Y is the non-inverting driver output. If DINV is high, then Y is the inverting driver output.
Z	10	-	$\pm 60\text{V}$ Fault Protected RS-485/RS-422 level. If DINV is low, then Z is the inverting driver output. If DINV is high, then Z is the non-inverting driver output.
V_{CC}	13, 14	8	System power supply input (4.5V to 5.5V).
INV	-	2	Receiver and driver polarity selection input. When driven high this pin swaps the polarity of the driver output and receiver input pins. If unconnected (floating) or connected low, normal RS-485 polarity conventions apply. Internally pulled low.
RINV	1	-	Receiver polarity selection input. When driven high this pin swaps the polarity of the receiver input pins. If unconnected (floating) or connected low, normal RS-485 polarity conventions apply. Internally pulled low.
DINV	8	-	Driver polarity selection input. When driven high this pin swaps the polarity of the driver output pins. If unconnected (floating) or connected low, normal RS-485 polarity conventions apply. Internally pulled low.

Truth Tables

TRANSMITTING					
INPUTS				OUTPUTS	
\overline{RE}	DE	DI	INV or DINV	Y	Z
X	1	1	0	1	0
X	1	0	0	0	1
X	1	1	1	0	1
X	1	0	1	1	0
0	0	X	X	High-Z	High-Z
1	0	X	X	High-Z*	High-Z*

NOTE: *Low Power Shutdown Mode (See [Note 11](#)), except for ISL31485E.

RECEIVING					
INPUTS					OUTPUT
\overline{RE}	DE (Half Duplex)	DE (Full Duplex)	A-B	INV or RINV	RO
0	0	X	$\geq -0.01V$	0	1
0	0	X	$\leq -0.2V$	0	0
0	0	X	$\leq 0.01V$	1	1
0	0	X	$\geq 0.2V$	1	0
0	0	X	Inputs Open or Shorted	X	1
1	0	0	X	X	High-Z*
1	1	1	X	X	High-Z

NOTE: *Low Power Shutdown Mode (See [Note 11](#)), except for ISL31485E.

Typical Operating Circuits

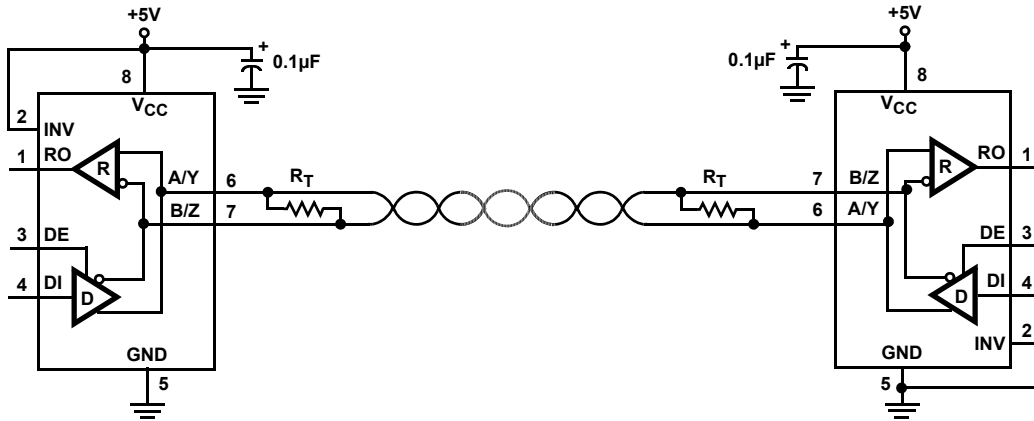

NOTE: The IC on the left has the cable connections swapped, so the INV pin is strapped high to invert its Rx and Tx polarity.

FIGURE 3. ISL31485E HALF DUPLEX EXAMPLE

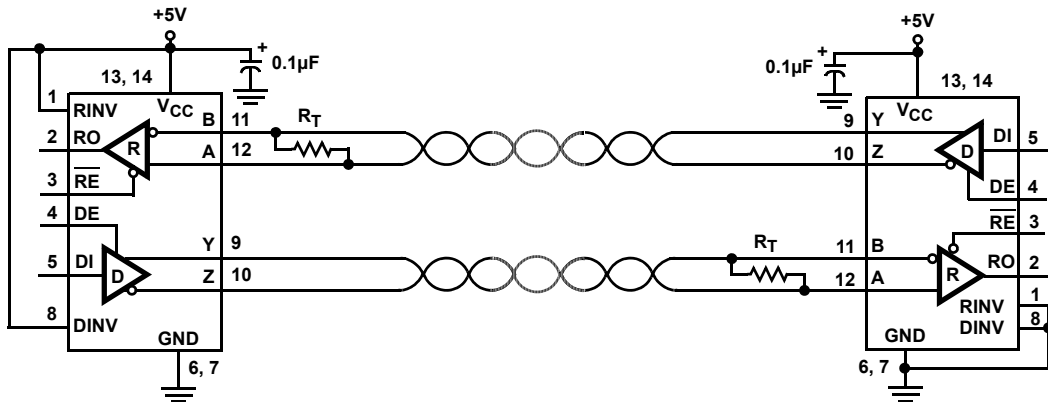

NOTE: The IC on the left has the cable connections swapped, so the INV pins (1, 8) are strapped high to invert its Rx and Tx polarity.

FIGURE 4. ISL31483E FULL DUPLEX EXAMPLE

Absolute Maximum Ratings

V _{CC} to Ground	7V
Input Voltages	
DI, INV, RINV, DINV, DE, \overline{RE}	-0.3V to (V _{CC} + 0.3V)
Input/Output Voltages	
A/Y, B/Z, A, B, Y, Z	±60V
A/Y, B/Z, A, B, Y, Z (Transient Pulse Through 100Ω, Note 15)	±80V
RO	-0.3V to (V _{CC} + 0.3V)
Short-circuit Duration	
Y, Z	Indefinite
ESD Rating	See Specification Table
Latch-up per JESD78, Level 2, Class A	+125°C

Thermal Information

Thermal Resistance (Typical)	θ_{JA} (°C/W)	θ_{JC} (°C/W)
8 Ld SOIC Package (Notes 4, 5)	104	47
14 Ld SOIC Package (Notes 4, 5)	78	42
Maximum Junction Temperature (Plastic Package)	+150°C	
Maximum Storage Temperature Range	-65°C to +150°C	
Pb-free Reflow Profile	see TB493	

Recommended Operating Conditions

Supply Voltage (V _{CC})	5V
Temperature Range	-40°C to +85°C
Bus Pin Common Mode Voltage Range	-25V to +25V

CAUTION: Do not operate at or near the maximum ratings listed for extended periods of time. Exposure to such conditions may adversely impact product reliability and result in failures not covered by warranty.

NOTES:

- θ_{JA} is measured with the component mounted on a high effective thermal conductivity test board in free air. See Tech Brief [TB379](#) for details.
- For θ_{JC} , the "case temp" location is taken at the package top center.

Electrical Specifications Test Conditions: V_{CC} = 4.5V to 5.5V; Unless Otherwise Specified. Typical values are at V_{CC} = 5V, T_A = +25°C ([Note 6](#)). **Boldface limits apply across the operating temperature range, -40°C to +85°C.**

PARAMETER	SYMBOL	TEST CONDITIONS	TEMP (°C)	MIN (Note 14)	TYP	MAX (Note 14)	UNIT
DC CHARACTERISTICS							
Driver Differential V _{OUT} (No load)	V _{OD1}		Full	-	-	V_{CC}	V
Driver Differential V _{OUT} (Loaded, Figure 5A)	V _{OD2}	R _L = 100Ω (RS-422)	Full	2.4	3.2	-	V
		R _L = 54Ω (RS-485)	Full	1.5	2.5	V_{CC}	V
		R _L = 54Ω (PROFIBUS, V _{CC} ≥ 5V)	Full	2.0	2.5	-	V
		R _L = 21Ω (Six 120Ω terminations for Star Configurations, V _{CC} ≥ 4.75V)	Full	0.8	1.3	-	V
Change in Magnitude of Driver Differential V _{OUT} for Complementary Output States	ΔV _{OD}	R _L = 54Ω or 100Ω (Figure 5A)	Full	-	-	0.2	V
Driver Differential V _{OUT} with Common Mode Load (Figure 5B)	V _{OD3}	R _L = 60Ω, -7V ≤ V _{CM} ≤ 12V	Full	1.5	2.1	V_{CC}	V
		R _L = 60Ω, -25V ≤ V _{CM} ≤ 25V (V _{CC} ≥ 4.75V)	Full	1.7	2.3		V
		R _L = 21Ω, -15V ≤ V _{CM} ≤ 15V (V _{CC} ≥ 4.75V)	Full	0.8	1.1	-	V
Driver Common-Mode V _{OUT} (Figure 5)	V _{OC}	R _L = 54Ω or 100Ω	Full	-1	-	3	V
		R _L = 60Ω or 100Ω, -20V ≤ V _{CM} ≤ 20V	Full	-2.5	-	5	V
Change in Magnitude of Driver Common-mode V _{OUT} for Complementary Output States	DV _{OC}	R _L = 54Ω or 100Ω (Figure 5A)	Full	-	-	0.2	V
Driver Short-circuit Current	I _{OSD}	DE = V _{CC} , -25V ≤ V _O ≤ 25V (Note 8)	Full	-250	-	250	mA
		At first fold-back, 22V ≤ V _O ≤ -22V	Full	-83		83	mA
		At second fold-back, 35V ≤ V _O ≤ -35V	Full	-13		13	mA
Logic Input High Voltage	V _{IH}	DE, DI, \overline{RE} , INV, RINV, DINV	Full	2.5	-	-	V
Logic Input Low Voltage	V _{IL}	DE, DI, \overline{RE} , INV, RINV, DINV	Full	-	-	0.8	V
Logic Input Current	I _{IN1}	DI	Full	-1	-	1	μA
		DE, \overline{RE} , INV, RINV, DINV	Full	-15	6	15	μA

Electrical Specifications Test Conditions: $V_{CC} = 4.5V$ to $5.5V$; Unless Otherwise Specified. Typical values are at $V_{CC} = 5V$, $T_A = +25^\circ C$ (Note 6). **Boldface limits apply across the operating temperature range, $-40^\circ C$ to $+85^\circ C$. (Continued)**

PARAMETER	SYMBOL	TEST CONDITIONS	TEMP ($^\circ C$)	MIN (Note 14)	TYP	MAX (Note 14)	UNIT	
Input/Output Current (A/Y, B/Z)	I_{IN2}	DE = 0V, $V_{CC} = 0V$ or 5.5V	$V_{IN} = 12V$	Full	-	110	250	μA
			$V_{IN} = -7V$	Full	-200	-75	-	μA
			$V_{IN} = \pm 25V$	Full	-800	± 240	800	μA
			$V_{IN} = \pm 60V$ (Note 17)	Full	-6	± 0.7	6	mA
Input Current (A, B) (Full Duplex Versions Only)	I_{IN3}	$V_{CC} = 0V$ or 5.5V	$V_{IN} = 12V$	Full	-	90	125	μA
			$V_{IN} = -7V$	Full	-100	-70	-	μA
			$V_{IN} = \pm 25V$	Full	-500	± 200	500	μA
			$V_{IN} = \pm 60V$ (Note 17)	Full	-3	± 0.5	3	mA
Output Leakage Current (Y, Z) (Full Duplex Versions Only)	I_{OZD}	$\overline{RE} = 0V$, DE = 0V, $V_{CC} = 0V$ or 5.5V	$V_{IN} = 12V$	Full	-	20	200	μA
			$V_{IN} = -7V$	Full	-100	-5	-	μA
			$V_{IN} = \pm 25V$	Full	-500	± 40	500	μA
			$V_{IN} = \pm 60V$ (Note 17)	Full	-3	± 0.15	3	mA
Receiver Differential Threshold Voltage	V_{TH}	A-B if INV or RINV = 0; B-A if INV or RINV = 1, $-25V \leq V_{CM} \leq 25V$	Full	-200	-100	-10	mV	
Receiver Input Hysteresis	ΔV_{TH}	$-25V \leq V_{CM} \leq 25V$	25	-	25	-	mV	
Receiver Output High Voltage	V_{OH1}	$V_{ID} = -10mV$	$I_O = -2mA$	Full	$V_{CC} - 0.5$	4.75	-	V
	V_{OH2}		$I_O = -8mA$	Full	2.8	4.2	-	V
Receiver Output Low Voltage	V_{OL}	$I_O = 6mA$, $V_{ID} = -200mV$		Full	-	0.27	0.4	V
Receiver Output Low Current	I_{OL}	$V_O = 1V$, $V_{ID} = -200mV$		Full	15	22	-	mA
Three-state (High Impedance) Receiver Output Current	I_{OZR}	$0V \leq V_O \leq V_{CC}$ (Note 16)		Full	-1	0.01	1	μA
Receiver Short-circuit Current	I_{OSR}	$0V \leq V_O \leq V_{CC}$		Full	± 12	-	± 110	mA
SUPPLY CURRENT								
No-load Supply Current (Note 7)	I_{CC}	DE = V_{CC} , RE = 0V or V_{CC} , DI = 0V or V_{CC}		Full	-	2.3	4.5	mA
Shutdown Supply Current	I_{SHDN}	DE = 0V, $\overline{RE} = V_{CC}$, DI = 0V or V_{CC} (Note 16)		Full	-	10	50	μA
ESD PERFORMANCE								
All Pins		Human Body Model (Tested per JESD22-A114E)		25	-	± 2	-	kV
		Machine Model (Tested per JESD22-A115-A)		25	-	± 700	-	V
DRIVER SWITCHING CHARACTERISTICS								
Driver Differential Output Delay	t_{PLH} , t_{PHL}	$R_D = 54\Omega$, $C_D = 50pF$ (Figure 6)	No CM Load	Full	-	70	125	ns
			$-25V \leq V_{CM} \leq 25V$	Full	-	-	350	ns
Driver Differential Output Skew	t_{SKEW}	$R_D = 54\Omega$, $C_D = 50pF$ (Figure 6)	No CM Load	Full	-	4.5	15	ns
			$-25V \leq V_{CM} \leq 25V$ (Note 18)	Full	-	-	25	ns
Driver Differential Rise or Fall Time	t_R , t_F	$R_D = 54\Omega$, $C_D = 50pF$ (Figure 6)	No CM Load	Full	70	170	300	ns
			$-25V \leq V_{CM} \leq 25V$	Full	70	-	550	ns
Maximum Data Rate	f_{MAX}	$C_D = 820pF$ (Figure 8)		Full	1	4	-	Mbps
Driver Enable to Output High	t_{ZH}	SW = GND (Figure 7), (Note 9)		Full	-	-	350	ns
Driver Enable to Output Low	t_{ZL}	SW = V_{CC} (Figure 7), (Note 9)		Full	-	-	300	ns
Driver Disable from Output Low	t_{LZ}	SW = V_{CC} (Figure 7)		Full	-	-	120	ns

Electrical Specifications Test Conditions: $V_{CC} = 4.5V$ to $5.5V$; Unless Otherwise Specified. Typical values are at $V_{CC} = 5V$, $T_A = +25^\circ C$ (Note 6). **Boldface limits apply across the operating temperature range, $-40^\circ C$ to $+85^\circ C$. (Continued)**

PARAMETER	SYMBOL	TEST CONDITIONS	TEMP ($^\circ C$)	MIN (Note 14)	TYP	MAX (Note 14)	UNIT
Driver Disable from Output High	t_{HZ}	SW = GND (Figure 7)	Full	-	-	120	ns
Time to Shutdown	t_{SHDN}	(Notes 11, 16)	Full	60	160	600	ns
Driver Enable from Shutdown to Output High	$t_{ZH(SHDN)}$	SW = GND (Figure 7), (Notes 11, 12, 16)	Full	-	-	2000	ns
Driver Enable from Shutdown to Output Low	$t_{ZL(SHDN)}$	SW = V_{CC} (Figure 7), (Notes 11, 12, 16)	Full	-	-	2000	ns
RECEIVER SWITCHING CHARACTERISTICS							
Maximum Data Rate	f_{MAX}	$-25V \leq V_{CM} \leq 25V$ (Figure 9)	Full	1	15	-	Mbps
		$-15V \leq V_{CM} \leq 15V$ (Figure 9)	Full	1	12	-	Mbps
Receiver Input to Output Delay	t_{PLH}, t_{PHL}	$-25V \leq V_{CM} \leq 25V$ (Figure 9)	Full	-	90	150	ns
Receiver Skew $t_{PLH} - t_{PHL}$	t_{SKD}	(Figure 9)	Full	-	4	10	ns
Receiver Enable to Output Low	t_{ZL}	$R_L = 1k\Omega$, $C_L = 15pF$, SW = V_{CC} (Figure 10), (Notes 10, 16)	Full	-	-	50	ns
Receiver Enable to Output High	t_{ZH}	$R_L = 1k\Omega$, $C_L = 15pF$, SW = GND (Figure 10), (Notes 10, 16)	Full	-	-	50	ns
Receiver Disable from Output Low	t_{LZ}	$R_L = 1k\Omega$, $C_L = 15pF$, SW = V_{CC} (Figure 10) (Note 16)	Full	-	-	50	ns
Receiver Disable from Output High	t_{HZ}	$R_L = 1k\Omega$, $C_L = 15pF$, SW = GND (Figure 10) (Note 16)	Full	-	-	50	ns
Time to Shutdown	t_{SHDN}	(Notes 11, 16)	Full	60	160	600	ns
Receiver Enable from Shutdown to Output High	$t_{ZH(SHDN)}$	$R_L = 1k\Omega$, $C_L = 15pF$, SW = GND (Figure 10), (Notes 11, 13, 16)	Full	-	-	2000	ns
Receiver Enable from Shutdown to Output Low	$t_{ZL(SHDN)}$	$R_L = 1k\Omega$, $C_L = 15pF$, SW = V_{CC} (Figure 10), (Notes 11, 13, 16)	Full	-	-	2000	ns

NOTES:

- All currents into device pins are positive; all currents out of device pins are negative. All voltages are referenced to device ground unless otherwise specified.
- Supply current specification is valid for loaded drivers when DE = 0V.
- Applies to peak current. See "Typical Performance Curves" beginning on page 14 for more information
- Keep $\overline{RE} = 0$ to prevent the device from entering SHDN.
- The \overline{RE} signal high time must be short enough (typically <100ns) to prevent the device from entering SHDN.
- Transceivers (except on the ISL31485E) are put into shutdown by bringing \overline{RE} high and DE low. If the inputs are in this state for less than 60ns, the parts are guaranteed not to enter shutdown. If the inputs are in this state for at least 600ns, the parts are guaranteed to have entered shutdown. See "Low Power Shutdown Mode" on page 13.
- Keep $\overline{RE} = V_{CC}$ and set the DE signal low time >600ns to ensure that the device enters SHDN.
- Set the \overline{RE} signal high time >600ns to ensure that the device enters SHDN.
- Parameters with MIN and/or MAX limits are 100% tested at $+25^\circ C$, unless otherwise specified. Temperature limits established by characterization and are not production tested.
- Tested according to TIA/EIA-485-A, Section 4.2.6 ($\pm 80V$ for 15ms at a 1% duty cycle).
- Does not apply to the ISL31485E. The ISL31485E has no Rx enable function and thus no SHDN function.
- See "Caution" statement under the "Recommended Operating Conditions" section on page 6.
- This parameter is not production tested.

Test Circuits and Waveforms

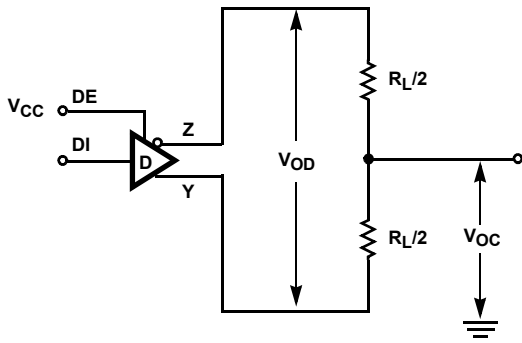

FIGURE 5A. V_{OD} AND V_{OC}

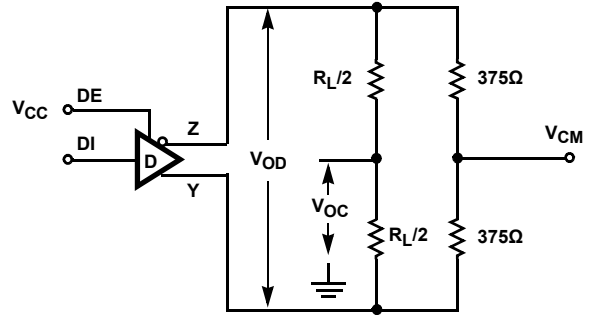
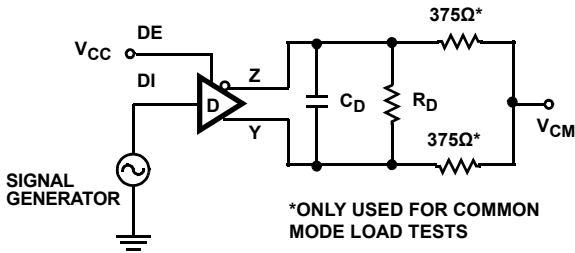

FIGURE 5B. V_{OD} AND V_{OC} WITH COMMON MODE LOAD

FIGURE 5. DC DRIVER TEST CIRCUITS



*ONLY USED FOR COMMON MODE LOAD TESTS

FIGURE 6A. TEST CIRCUIT

FIGURE 6. DRIVER PROPAGATION DELAY AND DIFFERENTIAL TRANSITION TIMES

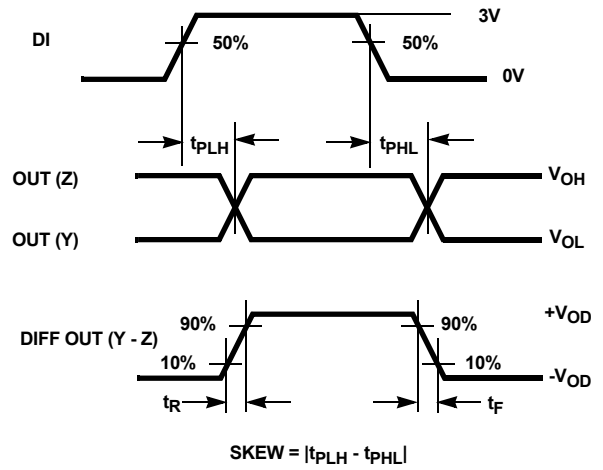
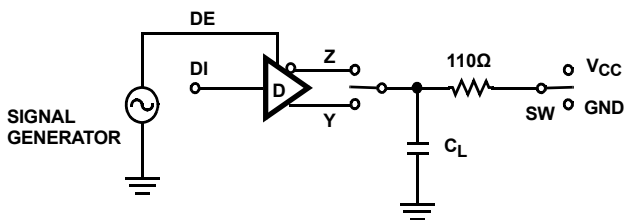

FIGURE 6B. MEASUREMENT POINTS



PARAMETER	OUTPUT	\overline{RE}	DI	SW	C_L (pF)
t_{HZ}	Y/Z	X	1/0	GND	50
t_{LZ}	Y/Z	X	0/1	V_{CC}	50
t_{ZH}	Y/Z	0 (Note 9)	1/0	GND	100
t_{ZL}	Y/Z	0 (Note 9)	0/1	V_{CC}	100
$t_{ZH(SHDN)}$	Y/Z	1 (Note 12)	1/0	GND	100
$t_{ZL(SHDN)}$	Y/Z	1 (Note 12)	0/1	V_{CC}	100

FIGURE 7A. TEST CIRCUIT

FIGURE 7. DRIVER ENABLE AND DISABLE TIMES

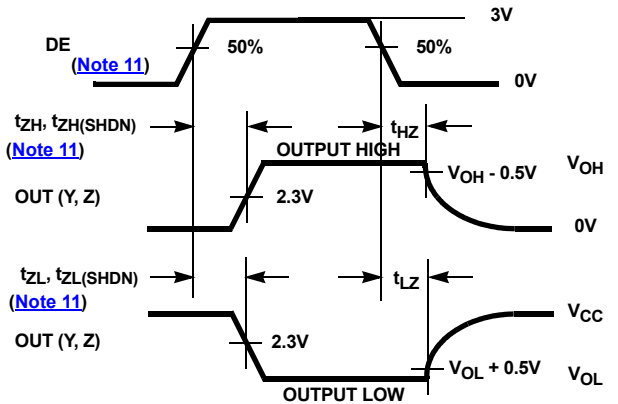

FIGURE 7B. MEASUREMENT POINTS

Test Circuits and Waveforms (Continued)

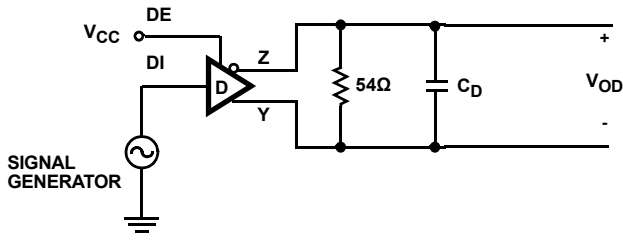

FIGURE 8A. TEST CIRCUIT

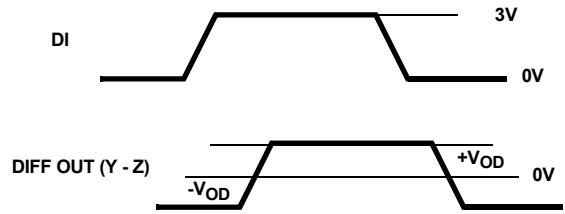

FIGURE 8B. MEASUREMENT POINTS

FIGURE 8. DRIVER DATA RATE

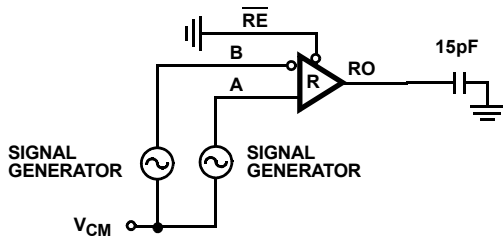

FIGURE 9A. TEST CIRCUIT

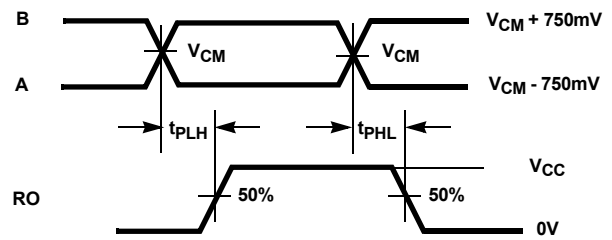

FIGURE 9B. MEASUREMENT POINTS

FIGURE 9. RECEIVER PROPAGATION DELAY AND DATA RATE

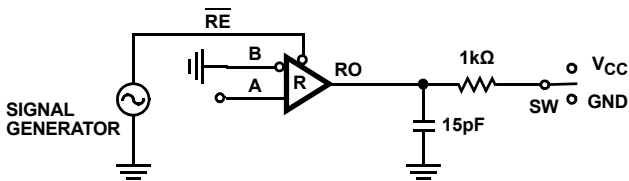

FIGURE 10A. TEST CIRCUIT

PARAMETER	DE	A	SW
t_{HZ}	0	+1.5V	GND
t_{LZ}	0	-1.5V	V_{CC}
t_{ZH} (Note 10)	0	+1.5V	GND
t_{ZL} (Note 10)	0	-1.5V	V_{CC}
$t_{ZH(SHDN)}$ (Note 13)	0	+1.5V	GND
$t_{ZL(SHDN)}$ (Note 13)	0	-1.5V	V_{CC}

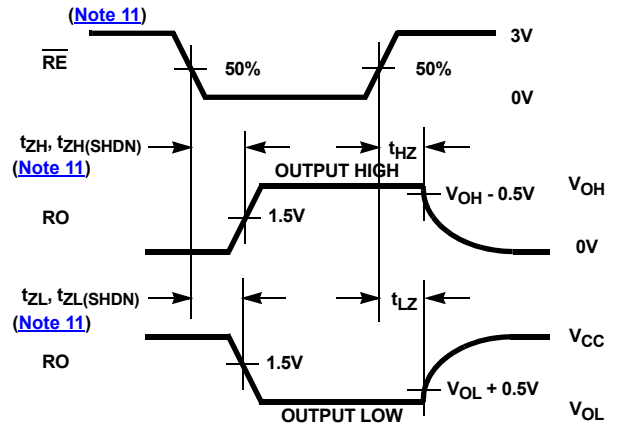

FIGURE 10B. MEASUREMENT POINTS

FIGURE 10. RECEIVER ENABLE AND DISABLE TIMES

Application Information

The RS-485 and RS-422 are differential (balanced) data transmission standards used for long haul or noisy environments. The RS-422 is a subset of RS-485, so RS-485 transceivers are also RS-422 compliant. The RS-422 is a point-to-multipoint (multidrop) standard, which allows only one driver and up to 10 (assuming one unit load devices) receivers on each bus. The RS-485 is a true multipoint standard, which allows up to 32 one unit load devices (any combination of drivers and receivers) on each bus. To allow for multipoint operation, the RS-485 specification requires that drivers must handle bus contention without sustaining any damage.

Another important advantage of RS-485 is the extended Common Mode Range (CMR), which specifies that the driver outputs and receiver inputs withstand signals that range from +12V to -7V. The RS-422 and RS-485 are intended for runs as long as 4000, so the wide CMR is necessary to handle ground potential differences, as well as voltages induced in the cable by external fields.

The ISL3148xE is a family of ruggedized RS-485 transceivers that improves on the RS-485 basic requirements and therefore increases system reliability. The CMR increases to $\pm 25V$, while the RS-485 bus pins (receiver inputs and driver outputs) include fault protection against voltages and transients up to $\pm 60V$. Additionally, larger than required differential output voltages (V_{OD}) increase noise immunity.

Receiver (Rx) Features

These devices utilize a differential input receiver for maximum noise immunity and common mode rejection. Input sensitivity is better than $\pm 200mV$, as required by the RS-422 and RS-485 specifications.

Receiver input (load) current surpasses the RS-422 specification of 3mA and is four times lower than the RS-485 "Unit Load (UL)" requirement of 1mA maximum. Thus, these products are known as "one-quarter UL" transceivers and there can be up to 128 of these devices on a network while still complying with the RS-485 loading specification.

The Rx functions with common mode voltages as great as $\pm 25V$, making them ideal for industrial, or long networks where induced voltages are a realistic concern.

All the receivers include a "full fail-safe" function that guarantees a high level receiver output if the receiver inputs are unconnected (floating), shorted together, or connected to a terminated bus with all the transmitters disabled (i.e., an idle bus).

Rx outputs feature high drive levels (typically 22mA at $V_{OL} = 1V$) to ease the design of optically coupled isolated interfaces. Except for the ISL31485E, Rx outputs are three-statable via the active low \overline{RE} input.

The Rx includes noise filtering circuitry to reject high frequency signals and typically rejects pulses narrower than 50ns (equivalent to 20Mbps).

Driver (Tx) Features

The RS-485/RS-422 driver is a differential output device that delivers at least 1.5V across a 54 Ω load (RS-485) and at least 2.4V across a 100 Ω load (RS-422). The drivers feature low propagation delay skew to maximize bit width and to minimize EMI and all drivers are three-statable via the active high DE input.

The driver outputs are slew rate limited to minimize EMI and to minimize reflections in unterminated or improperly terminated networks.

High Overvoltage (Fault) Protection Increases Ruggedness

The $\pm 60V$ (referenced to the IC GND) fault protection on the RS-485 pins, makes these transceivers some of the most rugged on the market. This level of protection makes the ISL3148xE perfect for applications where power (e.g., 24V and 48V supplies) must be routed in the conduit with the data lines, or for outdoor applications where large transients are likely to occur. When power is routed with the data lines, even a momentary short between the supply and data lines will destroy an unprotected device. The $\pm 60V$ fault levels of this family are at least **five times higher** than the levels specified for standard RS-485 ICs. The ISL3148xE protection is active whether the Tx is enabled or disabled and even if the IC is powered down.

If transients or voltages (including overshoots and ringing) greater than $\pm 60V$ are possible, then additional external protection is required.

Widest Common Mode Voltage (CMV) Tolerance Improves Operating Range

The RS-485 networks operating in industrial complexes, or over long distances, are susceptible to large CMV variations. Either of these operating environments may suffer from large node-to-node ground potential differences, or CMV pickup from external electromagnetic sources and devices with only the minimum required +12V to -7V CMR may malfunction. The ISL3148xE's extended $\pm 25V$ CMR is the widest available, allowing operation in environments that would overwhelm lesser transceivers. Additionally, the Rx will not phase invert (erroneously change state) even with CMVs of $\pm 40V$, or differential voltages as large as 40V.

Cable Invert (Polarity Reversal) Function

With large node count RS-485 networks, it is common for some cable data lines to be wired backwards during installation. When this happens the node is unable to communicate over the network. Once a technician finds the miswired node, he must then rewire the connector which is time consuming.

The ISL31483E and ISL31485E simplify this task by including cable invert pins (INV, DINV, RINV) that allow the technician to invert the polarity of the Rx input and/or the Tx output pins simply by moving a jumper to change the state of the invert pin(s). When the invert pin(s) is low, the IC operates like any standard RS-485 transceiver and the bus pins have their normal polarity definition of A and Y being noninverting and B and Z being inverting. With the invert pin high, the corresponding bus

pins reverse their polarity, so B and Z are now noninverting and A and Y become inverting.

Intersil's unique cable invert function is superior to that found on competing devices because the Rx full failsafe function is maintained even when the Rx polarity is reversed. Competitor devices implement the Rx invert function simply by inverting the Rx output. This means that with the Rx inputs floating or shorted together, the Rx appropriately delivers a logic 1 in normal polarity, but outputs a logic low when the IC is operated in the inverted mode. Intersil's innovative Rx design guarantees that with the Rx inputs floating, or shorted together ($V_{ID} = 0V$), the Rx output remains high regardless of the state of the invert pins.

The full duplex ISL31483E includes two invert pins that allow for separate control of the Rx and Tx polarities. If only the Rx cable is miswired, then only the RINV pin need be driven to a logic 1. If the Tx cable is miswired, then DINV must be connected to a logic high. The two half duplex versions have only one logic pin (INV) that, when high, switches the polarity of both the Tx and the Rx blocks.

High V_{OD} Improves Noise Immunity and Flexibility

The ISL3148xE driver design delivers larger differential output voltages (V_{OD}) than the RS-485 standard requires, or than most RS-485 transmitters can deliver. The typical $\pm 2.5V$ V_{OD} provides more noise immunity than networks built using many other transceivers.

Another advantage of the large V_{OD} is the ability to drive more than two bus terminations, which allows for utilizing the ISL3148xE in "star" and other multi-terminated, nonstandard network topologies.

[Figure 12](#), details the transmitter's V_{OD} vs I_{OUT} characteristic and includes load lines for four (30Ω) and six (20Ω) 120Ω terminations. [Figure 12](#) shows that the driver typically delivers $\pm 1.3V$ into six terminations and the "Electrical Specification" on [page 6](#) guarantees a V_{OD} of $\pm 0.8V$ at 21Ω over the full temperature range. The RS-485 standard requires a minimum $1.5V$ V_{OD} into two terminations, but the ISL3148xE deliver RS-485 voltage levels with 2x to 3x the number of terminations.

Hot Plug Function

When a piece of equipment powers up, there is a period of time where the processor or ASIC driving the RS-485 control lines (DE, RE) is unable to ensure that the RS-485 Tx and Rx outputs are kept disabled. If the equipment is connected to the bus, a driver activating prematurely during power-up may crash the bus. To avoid this scenario, the ISL3148xE devices incorporate a "Hot Plug" function. Circuitry monitoring V_{CC} ensures that, during power-up and power-down, the Tx and Rx outputs remain disabled, regardless of the state of DE and RE, if V_{CC} is less than $\approx 3.5V$. This gives the processor/ASIC a chance to stabilize and drive the RS-485 control lines to the proper states. [Figure 11](#) illustrates the power-up and power-down performance of the ISL3148xE compared to an RS-485 IC without the Hot Plug feature.

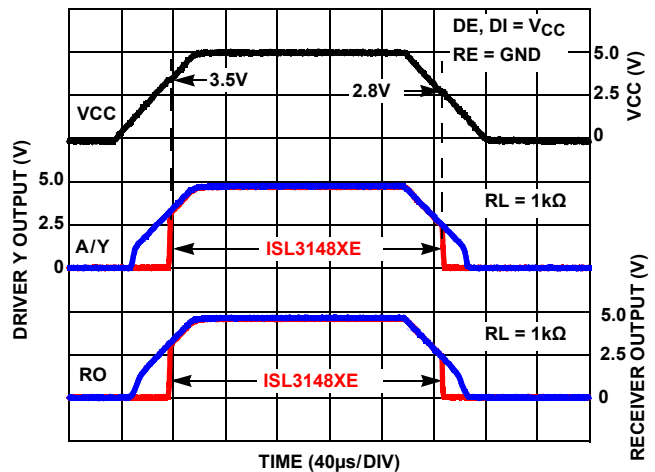

FIGURE 11. HOT PLUG PERFORMANCE ISL3148XE vs ISL83088E WITHOUT HOT PLUG CIRCUITRY

Data Rate, Cables and Terminations

The RS-485/RS-422 are intended for network lengths up to 4000, but the maximum system data rate decreases as the transmission length increases. These 1Mbps versions can operate at full data rates with lengths up to 800' (244m). Jitter is the limiting parameter at this data rate, so employing encoded data streams (e.g., Manchester coded or Return to Zero) may allow increased transmission distances.

Twisted pair is the cable of choice for RS-485/RS-422 networks. Twisted pair cables tend to pick up noise and other electromagnetically induced voltages as common mode signals, which are effectively rejected by the differential receivers in these ICs. Proper termination is imperative to minimize reflections and terminations are recommended unless power dissipation is an overriding concern. In point-to-point, or point-to-multipoint (single driver on bus like RS-422) networks, the main cable should be terminated in its characteristic impedance (typically 120Ω) at the end farthest from the driver. In multi-receiver applications, stubs connecting receivers to the main cable should be kept as short as possible. Multipoint (multi-driver) systems require that the main cable be terminated in its characteristic impedance at both ends. Stubs connecting a transceiver to the main cable should be kept as-short-as possible.

Built-in Driver Overload Protection

As stated previously, the RS-485 specification requires that drivers survive worst case bus contentions undamaged. These transceivers meet this requirement via driver output short-circuit current limits and on-chip thermal shutdown circuitry.

The driver output stages incorporate a double foldback short-circuit current limiting scheme which ensures that the output current never exceeds the RS-485 specification, even at the common mode and fault condition voltage range extremes. The first foldback current level ($\approx 70mA$) is set to ensure that the driver never folds back when driving loads with common mode voltages up to $\pm 25V$. The very low second foldback current setting ($\approx 9mA$) minimizes power dissipation if the Tx is enabled when a fault occurs.

In the event of a major short-circuit condition, devices also include a thermal shutdown feature that disables the drivers whenever the die temperature becomes excessive. This eliminates the power dissipation, allowing the die to cool. The drivers automatically reenables after the die temperature drops about 15 °C. If the contention persists, the thermal shutdown/re-enable cycle repeats until the fault is cleared. Receivers stay operational during thermal shutdown.

Low Power Shutdown Mode

These CMOS transceivers all use a fraction of the power required by competitive devices, but they also include a shutdown feature (except the ISL31485E) that reduces the already low quiescent I_{CC} to a 10 μ A trickle. These devices enter shutdown whenever the receiver and driver are *simultaneously* disabled ($\overline{RE} = V_{CC}$ and $DE = GND$) for a period of at least 600ns. Disabling both the driver and the receiver for less than 60ns guarantees that the transceiver will not enter shutdown.

Note that receiver and driver enable times increase when the transceiver enables from shutdown. Refer to [Notes 9, 10, 11, 12](#) and [13](#), at the end of the “Electrical Specification” table on [page 8](#), for more information.

Typical Performance Curves $V_{CC} = 5V, T_A = +25^\circ C$; Unless Otherwise Specified.

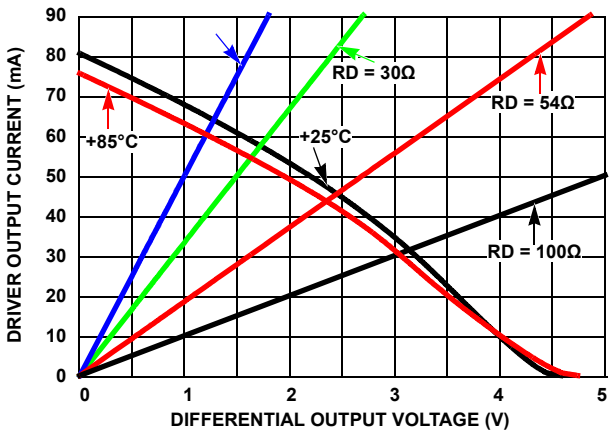

FIGURE 12. DRIVER OUTPUT CURRENT vs DIFFERENTIAL OUTPUT VOLTAGE

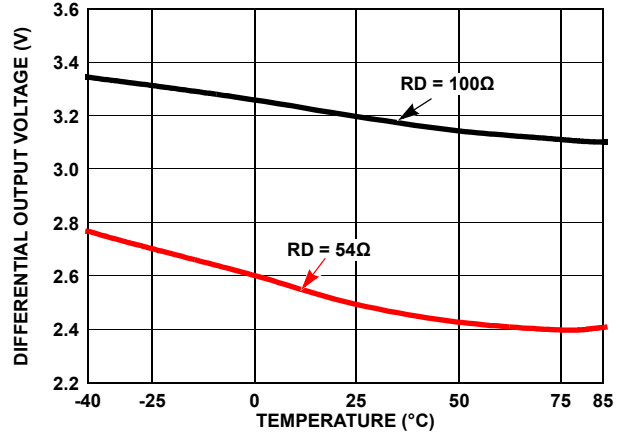

FIGURE 13. DRIVER DIFFERENTIAL OUTPUT VOLTAGE vs TEMPERATURE

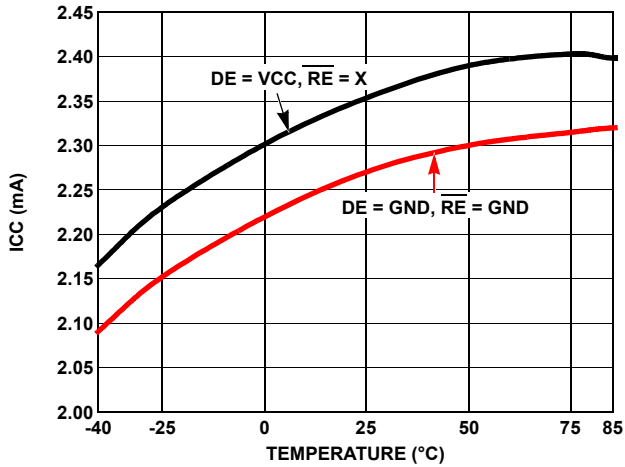

FIGURE 14. SUPPLY CURRENT vs TEMPERATURE

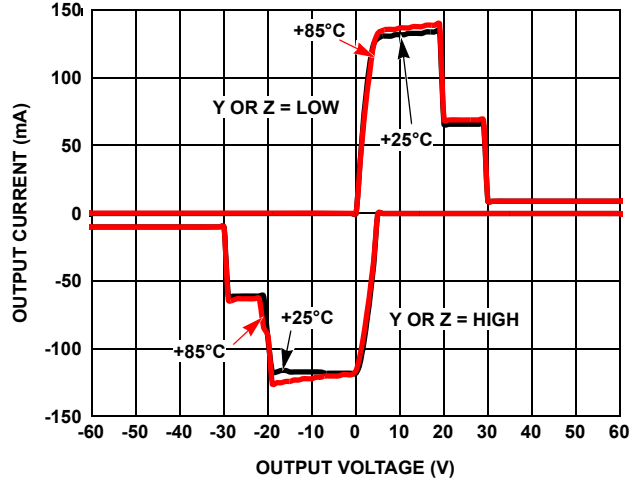

FIGURE 15. DRIVER OUTPUT CURRENT vs SHORT-CIRCUIT VOLTAGE

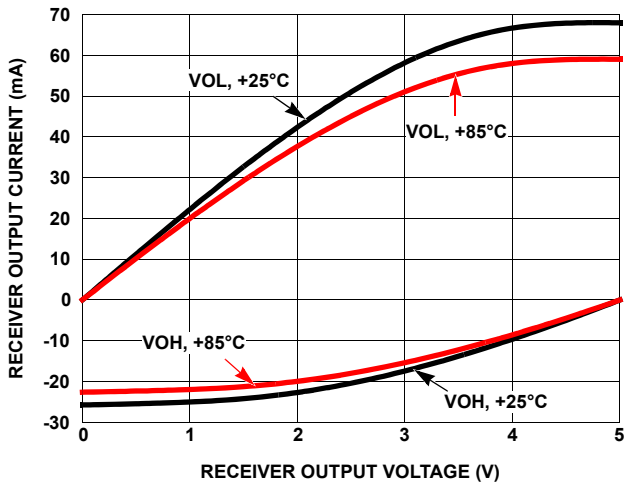

FIGURE 16. RECEIVER OUTPUT CURRENT vs RECEIVER OUTPUT VOLTAGE

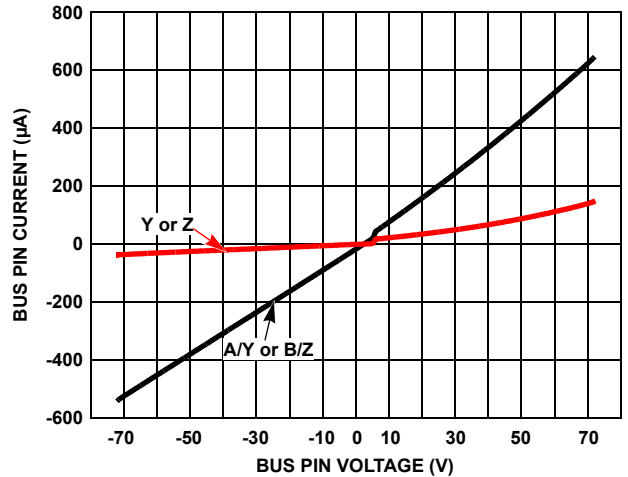

FIGURE 17. BUS PIN CURRENT vs BUS PIN VOLTAGE

Typical Performance Curves $V_{CC} = 5V, T_A = +25^\circ C$; Unless Otherwise Specified. (Continued)

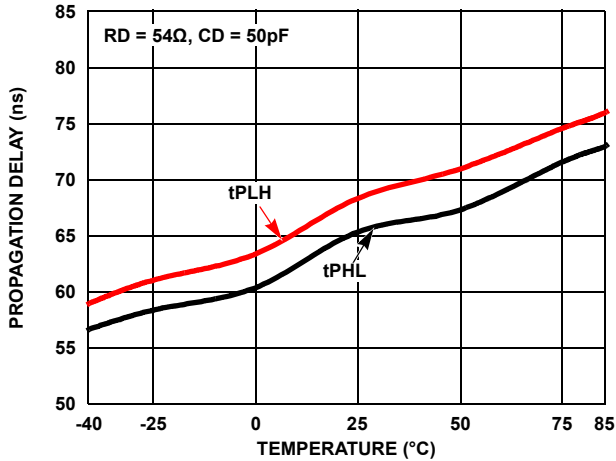

FIGURE 18. DRIVER DIFFERENTIAL PROPAGATION DELAY vs TEMPERATURE

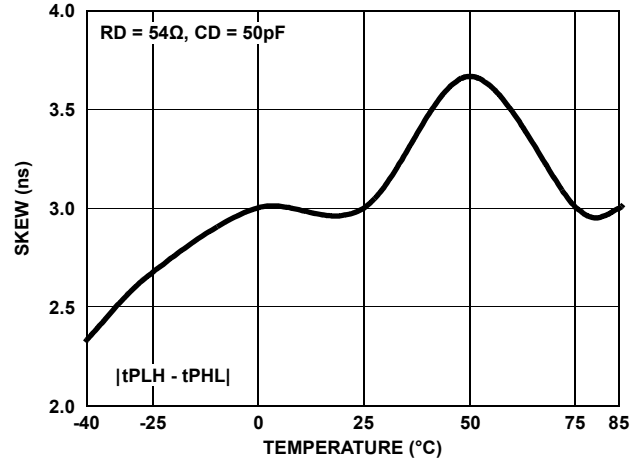

FIGURE 19. DRIVER DIFFERENTIAL SKEW vs TEMPERATURE

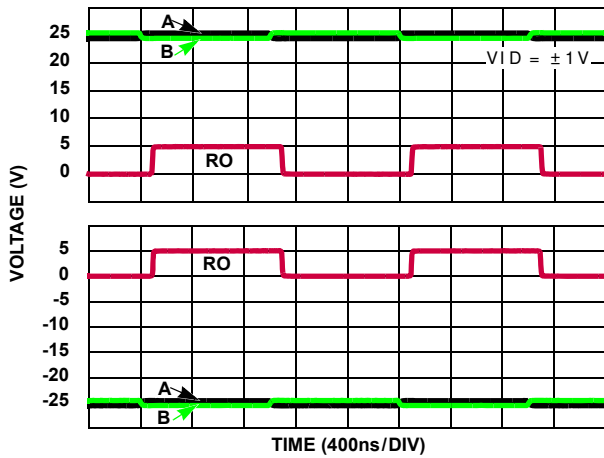

FIGURE 20. RECEIVER PERFORMANCE WITH $\pm 25V$ CMV

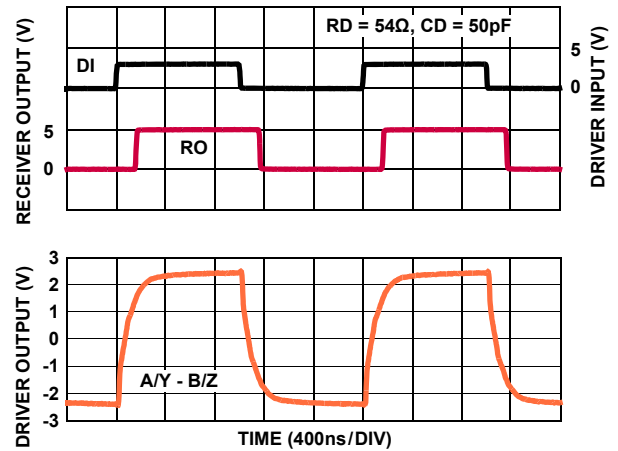

FIGURE 21. DRIVER AND RECEIVER WAVEFORMS

Die Characteristics

SUBSTRATE POTENTIAL (POWERED UP):

GND

PROCESS:

Si Gate BiCMOS

Revision History

The revision history provided is for informational purposes only and is believed to be accurate, but not warranted. Please go to web to make sure you have the latest Rev.

DATE	REVISION	CHANGE
May 13, 2015	FN7638.4	Changed "MAX" on "Driver Differential Rise or Fall Time" on page 7 from 400 to 550.
February 9, 2015	FN7638.3	Removed references to '480E and '486E in title and rest of document. Description on page 1, removed the last paragraph ("The '480E and '486E feature a logic . . .") Under "Features", in the 3rd bullet removed references to '480E and removed the 4th bullet ("Logic Supply (VL) . . .") On page 4, removed the '480E (col 2) and '486E (cols 5, 6, 7) entries from the "Pin Description" table and removed the "VL" "PD" and "NC" rows from this table. On page 6, removed row labeled "RO (480E, 496E)" in "Abs Max" table, removed all three 10 and 12 LD pkg entries from the "Thermal Info" section, removed Notes 5 and 7 and renumber all notes and note references. Stamped data sheet "Not recommended for New Designs. For an exact replacement, please see the ISL32483E, ISL32485E Series data sheet". Removed MSOP and TDFN from "Thermal Information" and (2) PODs. Thermal Information on page 6: 8 Ld SOIC Package, changed theta JA from 116 to 104. Thermal Information on page 6: 14 Ld SOIC Package, changed theta JA from 88 to 78 and theta JC from 38 to 42. On page 3, in Table 1 and the "Ordering Information" table, removed the devices marked "Coming Soon" (480E and 486E versions). Also removed unneeded PODs.
January 7, 2011	FN7638.2	Changed Note 17 to Note 15 in "Absolute Maximum Ratings" on page 6 Changed Notes 10 and 13 to Notes 9 and 12 in Figure 7A on page 9 Changed Note 14 to Note 13 in Figure 10A on page 10 Deleted Note 17 (See Figure 9 for more information and for performance over-temperature) Changed TYP on "Driver Differential Rise or Fall Time" on page 7 from 230 to 170 Added Figure 15 "DRIVER OUTPUT CURRENT vs SHORT-CIRCUIT VOLTAGE" Updated "Package Outline Drawing" on page 18. Updated to new POD format by removing table and moving dimensions onto drawing and adding land pattern.
September 8, 2010	FN7638.1	Corrected test conditions for "Receiver Output High Voltage" for "VOH5" on <u>page 7</u> from "IO = -500mA" to "IO = -500µA"
Jun 25, 2010	FN7638.0	Initial Release

About Intersil

Intersil Corporation is a leading provider of innovative power management and precision analog solutions. The company's products address some of the largest markets within the industrial and infrastructure, mobile computing and high-end consumer markets.

For the most updated datasheet, application notes, related documentation and related parts, please see the respective product information page found at www.intersil.com.

You may report errors or suggestions for improving this datasheet by visiting www.intersil.com/ask.

Reliability reports are also available from our website at www.intersil.com/support

© Copyright Intersil Americas LLC 2010-2015. All Rights Reserved.

All trademarks and registered trademarks are the property of their respective owners.

For additional products, see www.intersil.com/en/products.html

Intersil products are manufactured, assembled and tested utilizing ISO9001 quality systems as noted in the quality certifications found at www.intersil.com/en/support/qualandreliability.html

Intersil products are sold by description only. Intersil may modify the circuit design and/or specifications of products at any time without notice, provided that such modification does not, in Intersil's sole judgment, affect the form, fit or function of the product. Accordingly, the reader is cautioned to verify that datasheets are current before placing orders. Information furnished by Intersil is believed to be accurate and reliable. However, no responsibility is assumed by Intersil or its subsidiaries for its use; nor for any infringements of patents or other rights of third parties which may result from its use. No license is granted by implication or otherwise under any patent or patent rights of Intersil or its subsidiaries.

For information regarding Intersil Corporation and its products, see www.intersil.com

Package Outline Drawing

M14.15

14 LEAD NARROW BODY SMALL OUTLINE PLASTIC PACKAGE

Rev 1, 10/09

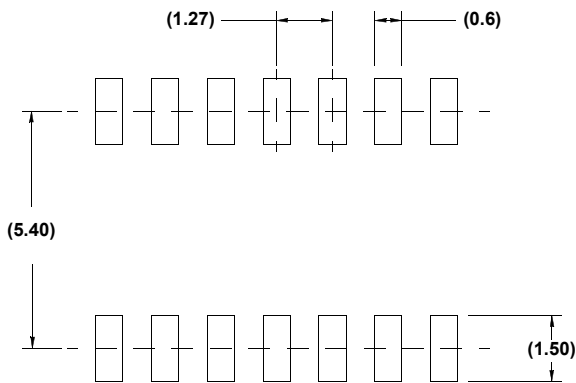
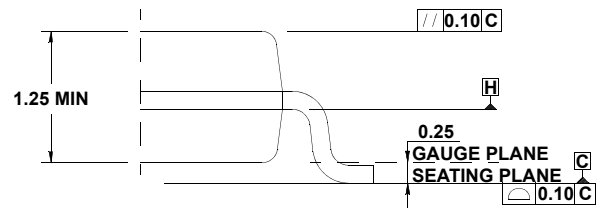
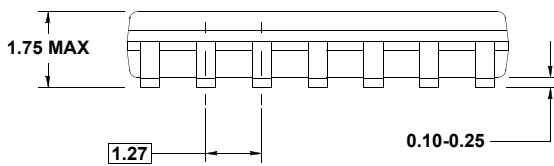
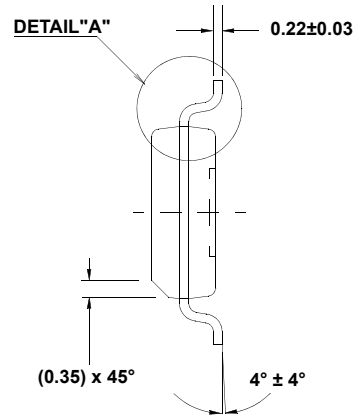
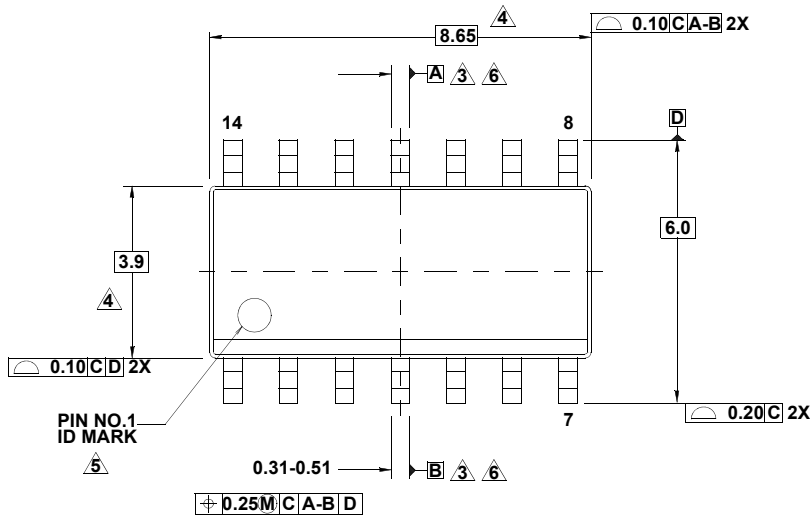

NOTES:

1. Dimensions are in millimeters. Dimensions in () for Reference Only.
2. Dimensioning and tolerancing conform to ASME Y14.5m-1994.
3. Datums A and B to be determined at Datum H.
4. Dimension does not include interlead flash or protrusions. Interlead flash or protrusions shall not exceed 0.25mm per side.
5. The pin #1 identifier may be either a mold or mark feature.
6. Does not include dambar protrusion. Allowable dambar protrusion shall be 0.10mm total in excess of lead width at maximum condition.
7. Reference to JEDEC MS-012-AB.

Package Outline Drawing

M8.15

8 LEAD NARROW BODY SMALL OUTLINE PLASTIC PACKAGE

Rev 4, 1/12

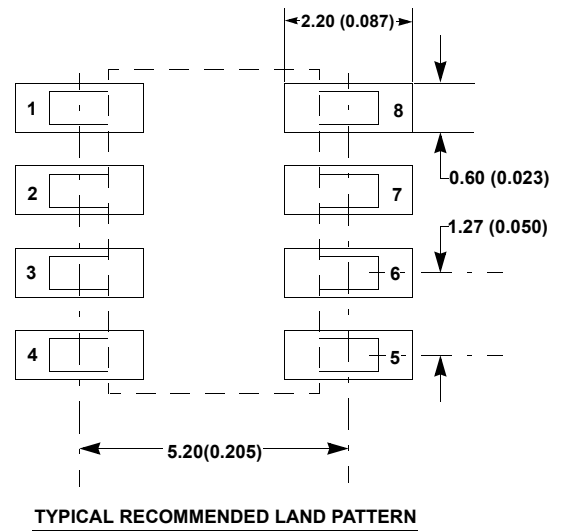
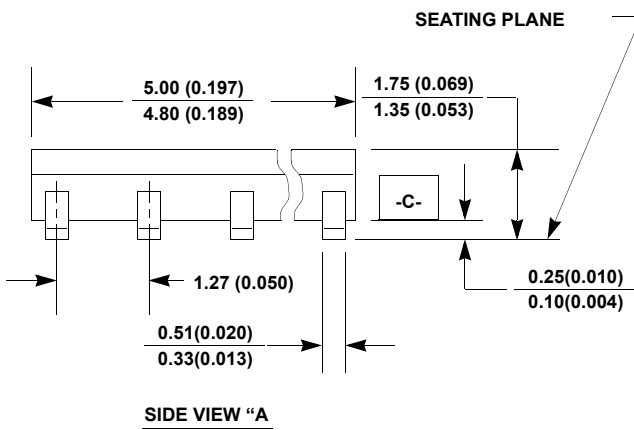
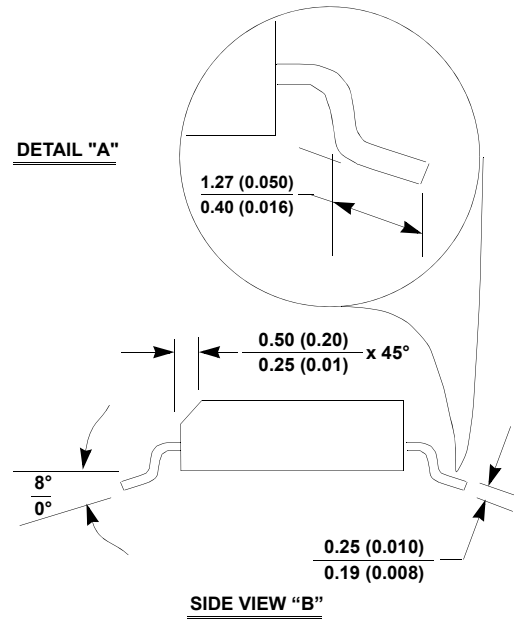
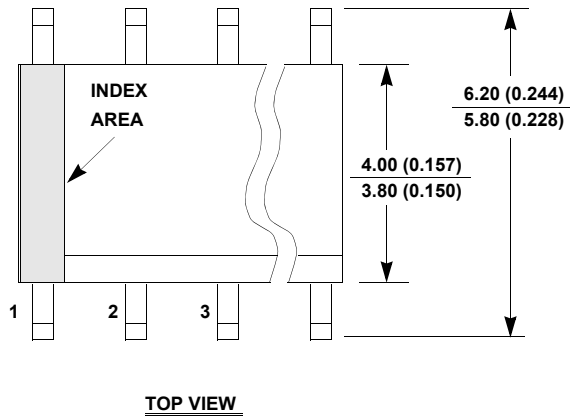

NOTES:

1. Dimensioning and tolerancing per ANSI Y14.5M-1994.
2. Package length does not include mold flash, protrusions or gate burrs. Mold flash, protrusion and gate burrs shall not exceed 0.15mm (0.006 inch) per side.
3. Package width does not include interlead flash or protrusions. Interlead flash and protrusions shall not exceed 0.25mm (0.010 inch) per side.
4. The chamfer on the body is optional. If it is not present, a visual index feature must be located within the crosshatched area.
5. Terminal numbers are shown for reference only.
6. The lead width as measured 0.36mm (0.014 inch) or greater above the seating plane, shall not exceed a maximum value of 0.61mm (0.024 inch).
7. Controlling dimension: MILLIMETER. Converted inch dimensions are not necessarily exact.
8. This outline conforms to JEDEC publication MS-012-AA ISSUE C.