

RECOMMENDED MOUNTING HOLE PATTERN FOR 1.57 [.062] THICK P.C. BOARD

- 1 PARTS COMPLY TO AMP SOLDERABILITY SPECIFICATION 109-11-3.
- 2 CONTACT IS PLATED OVERALL WITH 0.00127 [.000050] NICKEL, THEN 0.00076 [.000030] GOLD OVER CONTACT LENGTH INDICATED AND MATTE TIN LEAD ON SOLDER TAIL END.
- 3 CIRCUIT IDENTIFICATION CHARACTERS ARE ADJACENT TO THE INDICATED CAVITIES, BUT LOCATION AND ORIENTATION MAY DIFFER FROM PRINT.
- 4 DIMENSIONS IN BRACKETS ARE IN INCHES.
- 5 DRAIN HOLES LOCATED AS SHOWN. OPTIONAL CONSTRUCTION - ALL DRAIN HOLES LOCATED 90° AS SHOWN IN DETAIL A.
- 6 CONTACT IS PLATED OVERALL WITH 0.00127 [.000050] NICKEL, THEN 0.00076 [.000030] GOLD OVER CONTACT LENGTH INDICATED AND MATTE TIN ON SOLDER TAIL END.
- 7 SUPERSEDED BY 350761-5
- 8 DIMENSION SHOWN REPRESENT PRODUCT IN DRY CONDITION. ADDITIONAL 2% GROWTH DUE TO END USE LOCATION MOISTURE ABSORPTION MAY OCCUR AND SHOULD BE ACCOUNTED FOR.

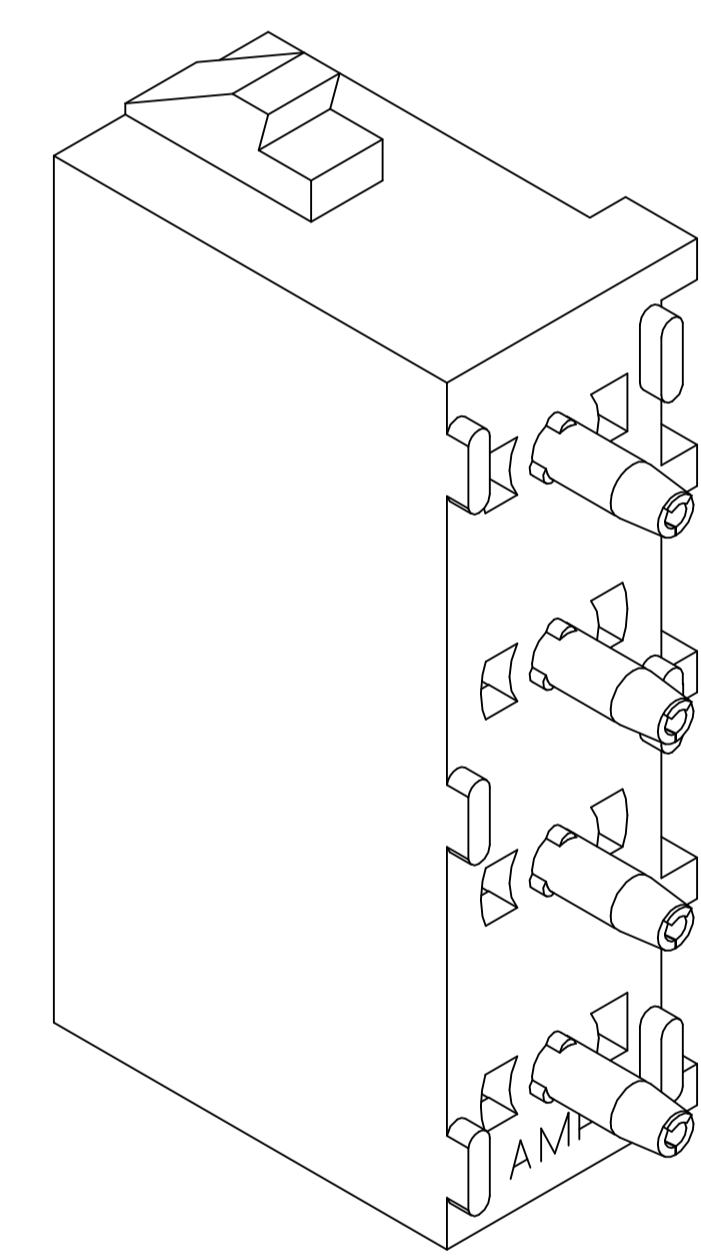

PHOSPHOR BRONZE, GOLD	NYLON, UL94V-2, NATURAL	350761-5
PHOSPHOR BRONZE, PRE-TIN	NYLON, UL94V-2, NATURAL	350761-4
PHOSPHOR BRONZE, GOLD	NYLON, UL94V-2, NATURAL	350761-3
CONTACT MATERIAL AND FINISH	HOUSING MATERIAL	PART NUMBER

THIS DRAWING IS A CONTROLLED DOCUMENT.		DIN R LEWIS 10-02-98	 TE Connectivity
DIMENSIONS: mm [INCHES]		CHK R SWING 10-02-98	
TOLERANCES UNLESS OTHERWISE SPECIFIED:		APP'D M TRULL 10-02-98	NAME
0 PLC ± -			SOCKET HEADER ASSEMBLY, 4 CIRCUIT UNIVERSAL MATE-N-LOK™
1 PLC ± -			APPLICATION SPEC
2 PLC ± 0.13 [.005]			SIZE CASE CODE DRAWING NO
3 PLC ± -			A1 00779 C=350761
4 PLC ± -			RESTRICTED TO
ANGLES ± ± 0°30'			WEIGHT
MATERIAL SEE TABLE	FINISH SEE TABLE	SCALE 5:1	SHEET 1 OF 1 REV N3