

> em4

em4 local

em4 local

- > Very compact and easy to program nanoPLC
- > Save time in designing your application using the most intuitive graphical function block language of the market
- > Measure accurately your high end industrial sensors with the embedded configurable analog inputs (including 4-20 mA)
- > Integrate easily one of our three high tech designs in your machine
- > Adapt your application along the way of its lifecycle thanks to the enhanced controlling performances



em4 local - Robust



em4 local - Glossy black



em4 local - Glossy white

| Specific characteristics | | | |
|-----------------------------------------------------|------------------------------------------------------------------------------------------------------------------------------------------|------------------------------------------------------------------------------------------------------------------------------------|----------------|
| Part number | 88 981 102 | 88 981 103 | 88 981 104 |
| Type | B26 | | |
| Inputs | 16 digital inputs (including 4 High Speed, 8 analog 0-10 V / potentiometers and 4 analog 0-10 V / 4-20 mA) | | |
| Outputs | 10 digital outputs (including 2 solid states 0.5 A PWM, 2 relays 6 A and 6 relays 8 A) | | |
| Supply | 24 VDC | | |
| Finish | Robust | Glossy black | Glossy white |
| On front panel color | Black RAL 9011 | | White RAL 9003 |
| On terminal block color | Blue RAL 5017 | | |
| Protection rating (in accordance with IEC/EN 60529) | IP 50 on front panel IP 20 on terminal block | IP 40 on front panel IP 20 on terminal block | |
| Weight | Without packing: 315 g With packing: 360 g | Without packing: 310 g With packing: 355 g | |
| Dimensions | Without packing: 124.6 x 90 x 62.6 mm / 4.91 x 3.54 x 2.46 inch With packing: 148 x 103 x 65 mm / 5.83 x 4.06 x 2.56 inch | Without packing: 124.6 x 90 x 60.4 mm / 4.91 x 3.54 x 2.38 inch With packing: 148 x 103 x 65 mm / 5.83 x 4.06 x 2.56 inch | |

| General characteristics | |
|------------------------------------------------------------------------------|--------------------------------------------------------------------------------------------------------------------------------------------------------------------------------------------------------------------------------|
| Products certification (in accordance with IEC/EN 60529) | CE, cULus Listed |
| Conformity with the low voltage directive (in accordance with BT 2006/95/EC) | IEC/EN 61131-2 (Open equipment) |
| Conformity with the EMC directive (in accordance with 2004/108/EC) | IEC/EN 61000-6-1 (Residential, commercial and light-industrial environments) IEC/EN 61000-6-2 (Industrial) IEC/EN 61000-6-3 (Residential, commercial and light-industrial environments) IEC/EN 61000-6-4 (Industrial) |
| Earthing | None |
| Overvoltage category | 3 in accordance with IEC/EN 60664-1 |
| Pollution | Degree: 2 in accordance with IEC/EN 61131-2 |
| Maximum utilization altitude | Operation: 2000 m Transport: 3000 m |
| Mechanical resistance | Immunity to vibrations IEC/EN 60068-2-6, Fc test Immunity to shock IEC/EN 60068-2-27, Ea test |
| Resistance to electrostatic discharge | Immunity to ESD IEC/EN 61000-4-2, level 3 |

| | |
|---------------------------------------------------------------------------|---------------------------------------------------------------------------------------------------------------------------------------------------------------------------------------------------------------------------------------------------------------------------------------------------------------------------------------------------------------------------------------------------------------------------|
| Resistance to HF interference (Immunity) | Immunity to radiated electrostatic fields IEC/EN 61000-4-3, level 3 Immunity to fast transients (burst immunity) IEC/EN 61000-4-4, level 3 Immunity to shock waves IEC/EN 61000-4-5 Radio frequency in common mode IEC/EN 61000-4-6, level 3 |
| Conducted and radiated emissions (in accordance with EN 55022/11 group 1) | Class B |
| Operation temperature | -20°C (-4°F) → +60°C (140°F) (+40°C (104°F) in a non-ventilated enclosure) |
| Storage temperature | -40°C (-40°F) → +80°C (176°F) |
| Relative humidity | 95% max. (no condensation or dripping water) |
| Screw terminals connection capacity | Flexible wire with ferrule: 1 conductor: 0.2 to 2.5 mm ² (AWG 24-14) Flexible wire with ferrule: 2 conductors: 0.2 to 0.75 mm ² (AWG 24-18) Rigid wire: 1 conductor: 0.2 to 2.5 mm ² (AWG 24-14) Rigid wire: 2 conductors: 0.2 to 0.75 mm ² (AWG 24-18) Tightening torque: 0.5 N.m (4.5 lb-in) (tighten using screwdriver diam. 3.5 mm) Stripping length: 6 mm |

Processing characteristics

| | |
|---------------------------------------------|------------------------------------------------------------------------------------------------------------------------------------------------------------------------------------------------|
| LCD display | Display with 4 lines of 18 characters |
| Programming method | FBD (Function Block Diagram), including SFC (Sequential Function Chart, Grafset) |
| Program size | Function blocks: typically 1000 blocks Macro blocks: 64 max. (256 blocks per macro) |
| Program memory | Flash |
| Removable memory | N.A |
| Data memory | 2 k octets |
| Backup time (in the event of power failure) | Program and settings in the controller: 10 years Data memory: 10 years |
| Data backup | Data backup in the flash memory is guaranteed if the product is powered on more than 10 seconds |
| Cycle time | From 2 ms to 90 ms, default value: 10 ms |
| Clock data retention | 10 years (lithium battery) at 25°C (77°F) |
| Clock drift | Drift < 12 min/year (at 25°C (77°F)) 6 s / month (at 25°C (77°F) with user-definable correction of drift). Synchronizable by network |
| Timer block accuracy | 0.5 % +/- 2 cycle time |
| Start up time on power up | < 3 s base alone, < 1.5 s base + 2 expansions + accessory interface (USB or Modbus RS485) |
| Self test | Test firmware integrity (checksum memory) Stability of the internal power supply Check the conformity of the em4 device configuration with the configuration in the application program. |

Supply

| | |
|----------------------------------------|----------------------------------------------------|
| Nominal voltage | 24 VDC (-15% / +20%) |
| Operating limits | 20.4 - 28.8 VDC |
| Immunity from micro power cuts | ≤ 1 ms (repetition 20 times) |
| Max. absorbed power | 4W @ 24 VDC, 5.3 W @ 28.8 V, - 0.3 W backlight OFF |
| Protection against polarity inversions | Yes |

Inputs

Digital and high speed digital inputs 24 VDC - 4 inputs from I1 to I4

Input used as digital input

| | |
|----------------------------------|-----------------------------------------------------|
| Input voltage | 24 VDC (-15% / +20%) |
| Input current | 1.8 mA @ 20.4 V 2.1 mA @ 24 V 2.5 mA @ 28.8 V |
| Input impedance | 11.6 kΩ |
| Logic 1 voltage threshold | ≥ 15 VDC |
| Making current at logic state 1 | ≥ 1.3 mA |
| Logic 0 voltage threshold | ≤ 10 VDC |
| Release current at logic state 1 | ≤ 0.8 mA |
| Response time | 1 to 2 cycle times |
| Sensor type | Contact or 3-wire PNP |
| Conforming to IEC/EN 61131-2 | Type 1 |

| | |
|---------------------------------------------------------------------------------------------------|----------------------------------------------------------------------------------------------------------------------------------------------------------------------------------------------------------------------------------------------------------------------------------------------------------------------------------------------------------------------------------------------------------------------------------------------------------|
| Input type | Resistive |
| Isolation between power supply and inputs | None |
| Isolation between inputs | None |
| Protection against polarity inversions | Yes |
| Status indicator | On LCD screen |
| Cable length | ≤ 100 m |
| Input used as high speed digital input | |
| Maximum counting frequency | 3 channels encoder (I1, I2, I3): 20 kHz* 2 independent counters (I1, I2) (I3, I4) (Cumul, IND, DIR): 2 channels: 40 kHz*, 4 channels: 20 kHz*, 2 independent counters (I1, I2) (I3, I4) (PH, PH2): 2/4 channels: 20 kHz* 4 independent counters (I1, I2, I3, I4) (Up/Down): 1 channel: 60 kHz*, 2 channels: 40 kHz*, > 2 channels: 20 kHz* * with a time cycle ≤ 10 ms and a ton / toff = 50% +/- 5%, level 0 < 2V and level 1 > 20,4V |
| Other functions | 4 chronometers (I1, I2, I3, I4) 4 tachometers (I1, I2, I3, I4) |
| Cable length | ≤ 3 m with shielded twisted cable |
| Digital 24 VDC and analog inputs 12 bits / 28.8 V - potentiometer - 8 inputs from I5 to IC | |
| Input used as digital input | |
| Input voltage | 24 VDC (-15% / +20%) |
| Input current | 1.8 mA @ 20.4 V 2.1 mA @ 24 V 2.5 mA @ 28.8 V |
| Input impedance | 11.6 kΩ |
| Logic 1 voltage threshold | ≥ 11 VDC |
| Making current at logic state 1 | ≥ 1 mA |
| Logic 0 voltage threshold | ≤ 9 VDC |
| Release current at logic state 1 | ≤ 0.7 mA |
| Response time | 1 to 2 cycle times |
| Sensor type | Contact or 3-wire PNP |
| Conforming to IEC/EN 61131-2 | Type 1 |
| Input type | Resistive |
| Isolation between power supply and inputs | None |
| Isolation between inputs | None |
| Protection against polarity inversions | Yes |
| Status indicator | On LCD screen |
| Cable length | ≤ 100 m |
| Input used as analog input | |
| Measuring range | 0 → 10 V or 0 → V power supply |
| Input impedance | 11.6 kΩ |
| Maximum value without destruction | 28.8 VDC max |
| Input type | Common mode |
| Resolution | 12 bit at maximum input voltage (10.5 bit at 10V) |
| Value of LSB | 7.03 mV |
| Conversion time | Controller cycle time |
| Maximum error in 0-10V mode | +/- 1.1 % of full scale at 25°C (77°F) +/- 1.6 % of full scale at 55°C (131°F) |
| Maximum error in 0-V power supply mode | +/- 2 % of full scale at 25°C (77°F) +/- 3 % of full scale at 55°C (131°F) |
| Repeat accuracy at 55°C (131°F) | +/- 0.5 % |
| Isolation between analog channel and power supply | None |
| Protection against polarity inversions | Yes |
| Potentiometer control | 2.2 kΩ / 0.5 W (recommended), 10 KΩ max. |
| Cable length | ≤ 10 m with shielded twisted cable (sensor not isolated) |

Digital 24 VDC and analog inputs 12 bits / 10 V & 11 bits / 0-20 mA- potentiometer - 4 inputs from ID to IG

| Input used as digital input (power off state) | |
|---------------------------------------------------|-----------------------------------------------------------------------------------------------|
| Input voltage | 24 VDC (-15% / +20%) |
| Input current | 1.5 mA @ 20.4 V 1.7 mA @ 24 V 2.1 mA @ 28.8 V |
| Input impedance | 13.9 kΩ |
| Logic 1 voltage threshold | ≥ 11 VDC |
| Making current at logic state 1 | ≥ 0.8 mA |
| Logic 0 voltage threshold | ≤ 8 VDC |
| Release current at logic state 1 | ≤ 0.5 mA |
| Response time | 1 to 2 cycle times |
| Sensor type | Contact or 3-wire PNP |
| Conforming to IEC/EN 61131-2 | Type 1 |
| Input type | Resistive |
| Isolation between power supply and inputs | None |
| Isolation between inputs | None |
| Protection against polarity inversions | No |
| Status indicator | On LCD screen |
| Cable length | ≤ 100 m |
| Input used as 0-10 V analog input | |
| Measuring range | 0 → 10 V |
| Input impedance | 13.9 kΩ |
| Maximum value without destruction | 28.8 VDC max |
| Input type | Common mode |
| Resolution | 12 bit / 10V |
| Value of LSB | 2.45 mV |
| Conversion time | Controller cycle time |
| Maximum error at 25°C (77°F) | +/- 0.8 % of full scale |
| Maximum error at 55°C (131°F) | +/- 1.2 % of full scale |
| Repeat accuracy at 55°C (131°F) | +/- 0.5 % |
| Isolation between analog channel and power supply | None |
| Protection against polarity inversions | Yes for voltage ≤ 10 V |
| Potentiometer control | 2.2 kΩ / 0.5 W (recommended), 10 KΩ max. |
| Cable length | ≤ 10 m with shielded twisted cable (sensor not isolated) |
| Input used as 0-20 mA analog input | |
| Measuring range | 0 → 20 mA (4 → 20 mA by the application) |
| Input impedance | 245 Ω |
| Maximum value without destruction | 30 mA max |
| Input type | Common mode |
| Resolution | 11 bit (normalized at 0 - 2000) / 20 mA |
| Value of LSB | 10 μA |
| Conversion time | Controller cycle time |
| Maximum error at 25°C (77°F) | +/- 1.2 % of full scale |
| Maximum error at 55°C (131°F) | +/- 1.7 % of full scale |
| Repeat accuracy at 55°C (131°F) | +/- 0.5 % |
| Isolation between analog channel and power supply | None |
| Protection against polarity inversions | Yes |
| Overvoltage protection | Yes If the input voltage is > 7 V, this one is automatically switched on 0-10V configuration. |
| Cable length | ≤ 30 m with shielded twisted cable (sensor not isolated) |

| Outputs | | | | |
|------------------------------------------------------------------------|-----------------------------------------------------------------------------------------------------------------------------------------------------------------------------------------------------------------------------------------------------------------------------------------------------------------------|---------|--------|-------|
| Digital / PWM solid state output - 2 solid state outputs from O1 to O2 | | | | |
| Output used as digital output | | | | |
| Breaking voltage | 10 → 28.8 VDC | | | |
| Nominal voltage | 12 / 24 VDC | | | |
| Nominal current | 0.5 A on resistive load @ 25°C (77°F) | | | |
| Max. breaking current | 0.625 A | | | |
| Non repetitive overload current | 1 A | | | |
| Maximum breaking current in the common | 1 A | | | |
| Voltage drop | < 1 V for I = 0.5 A | | | |
| Response time | Make = 1 cycle time + 30 μs typical Release = 1 cycle time + 40 μs typical | | | |
| Built-in protections | Against overloads and short-circuits: Yes Against over voltages (*): Yes Against inversions of power supply: Yes (* In the absence of a potential free contact between the output of the programmable logic controller and the load | | | |
| Min. load | 1 mA | | | |
| Galvanic isolation | No | | | |
| Cable length | ≤ 10 m | | | |
| Truth table of the default | | Command | Output | Fault |
| | Normal condition | 0 | 0 | No |
| | | 1 | 1 | No |
| | Overheating | 0 | 0 | No |
| | | 1 | 0 | Yes |
| | Underpowered | 0 | 0 | X |
| | | 1 | 0 | X |
| | Short circuit (current limit) | 0 | 0 | No |
| | | 1 | 0 | Yes |
| Output used as PWM output | | | | |
| PWM frequency | 14.11 Hz ; 56.45 Hz ; 112.90 Hz ; 225.80 Hz ; 451.59 Hz ; 1758.24 Hz | | | |
| PWM cyclic ratio | 0 → 100 % 100 steps | | | |
| PWM Max. error | ≤ 2 % (from 10 % → 90 %) | | | |
| Status indicator | On LCD screen | | | |
| Cable length | ≤ 10 m with shielded twisted cable | | | |
| Distance between the power source and the static outputs | ≤ 30 m | | | |
| 6 A relay output - 2 outputs from O3 to O4 | | | | |
| Breaking voltage | 250 VAC max | | | |
| Breaking current | 6 A | | | |
| Maximum breaking current in the common | IEC @ 25°C (77°F): 12 A IEC @ 60°C (140°F) or UL: 10 A | | | |
| Mechanical life | 5 000 000 operations (cycles) | | | |
| Electrical durability for 50 000 operating cycles | 24 VDC tau = 0 ms: 6 A, tau = 7 ms: 3 A, tau = 15 ms: 1.8 A Usage category DC-12: 24 V, 6 A Usage category DC-14: 24 V, 1.8 A 250 VAC cos phi = 1: 6 A, cos phi = 0.7: 5 A, cos phi = 0.4: 2.5 A Usage category AC-12: 250 V, 6 A Usage category AC-13: 250 V, 5 A Usage category AC-15: 250 V, 2 A | | | |
| Minimum switching capacity | 100 mA (at minimum voltage of 12V) | | | |
| Maximum operating rate | Off load: 10 Hz At operating current: 0.1 Hz | | | |
| Voltage for withstanding shocks | In accordance with IEC/EN 60947-1 and IEC/EN 60664-1: 4 kV | | | |
| Response time | Make = 1 cycle time + 8 ms typical Release = 1 cycle time + 4 ms typical | | | |
| Built-in protections | Against short-circuits: None Against over voltages and overload: None | | | |
| Status indicator | On LCD screen | | | |
| Cable length | ≤ 30 m | | | |

8 A relay output - 6 outputs from O5 to OA

| | |
|---------------------------------------------------|----------------------------------------------------------------------------------------------------------------------------------------------------------------------------------------------------------------------------------------------------------------------------------------------------------------------------------------------------|
| Breaking voltage | 250 VAC max |
| Breaking current | 8 A, $\geq 55^{\circ}\text{C}$: 6 A |
| Maximum breaking current in the common | IEC @ 25°C (77°F): C3, C6: 8 A ; C4, C5: 16 A IEC @ 60°C (140°F) or UL: C3, C6: 8 A ; C4, C5: 10 A |
| Mechanical life | 20 000 000 operations (cycles) |
| Electrical durability for 50 000 operating cycles | 24 VDC $\tau = 0$ ms: 8 A, $\tau = 7$ ms: 3 A, $\tau = 15$ ms: 1.5 A Usage category DC-12: 24 V, 8 A Usage category DC-14: 24 V, 1.5 A 250 VAC $\cos \phi = 1$: 8 A, $\cos \phi = 0.7$: 4.75 A, $\cos \phi = 0.4$: 3 A Usage category AC-12: 250 V, 8 A Usage category AC-13: 250 V, 4.3 A Usage category AC-15: 250 V, 1.5 A |
| Minimum switching capacity | 100 mA (at minimum voltage of 12V) |
| Maximum operating rate | Off load: 10 Hz At operating current: 0.1 Hz |
| Voltage for withstanding shocks | In accordance with IEC/EN 60947-1 and IEC/EN 60664-1: 4 kV |
| Response time | Make = 1 cycle time + 10 ms typical Release = 1 cycle time + 5 ms typical |
| Built-in protections | Against short-circuits: None Against over voltages and overload: None |
| Status indicator | On LCD screen |
| Cable length | ≤ 30 m |

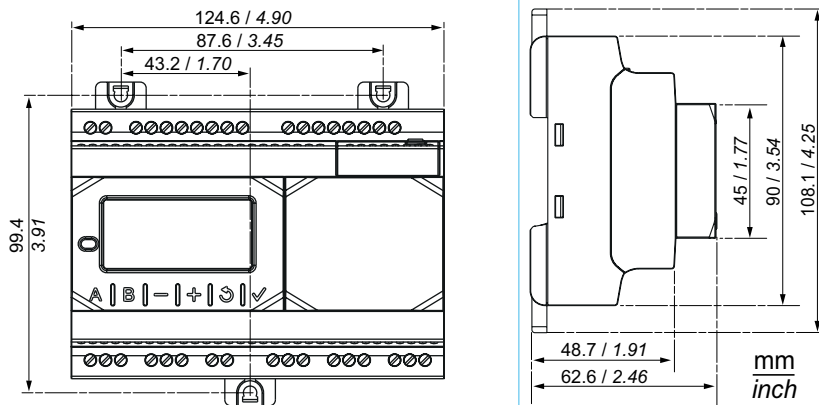
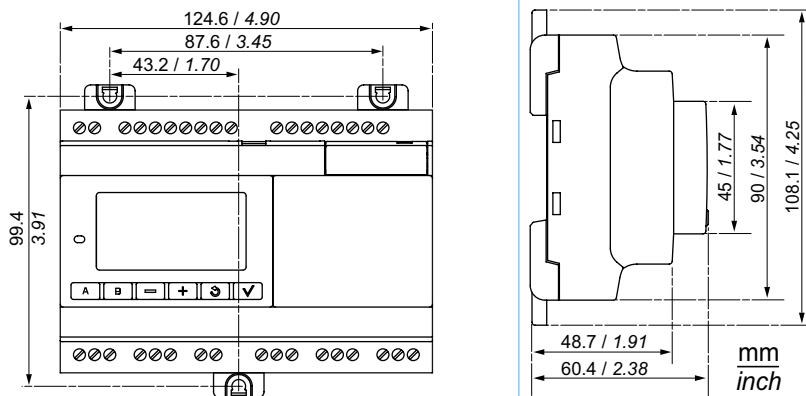
Schemes**Dimensions****B26 Robust****B26 Glossy**

Connections

Inputs

I1 ... IG 0/1

+ 24 VDC

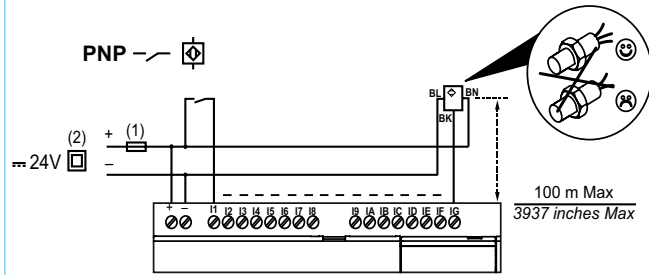
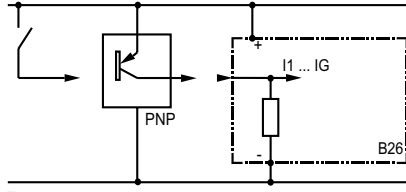

I5 ... IC U

+ 24 VDC

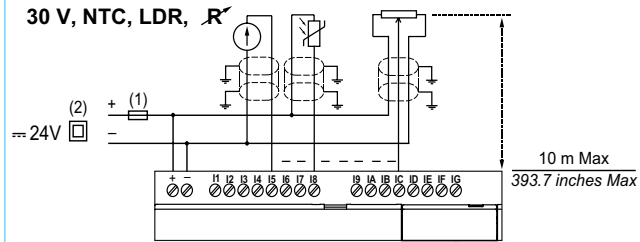
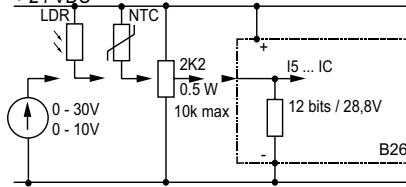

ID ... IG U / I

+ 24 VDC

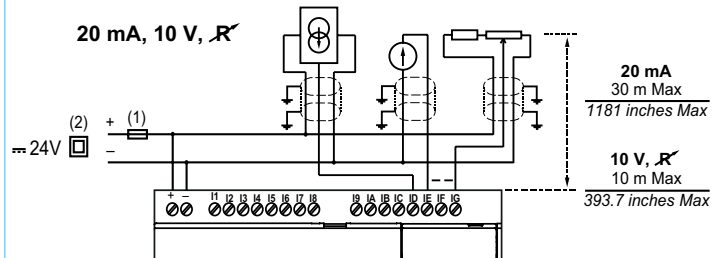
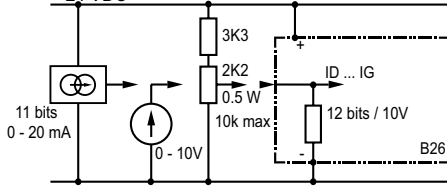

I1 ... I4 2604

+ 24 VDC

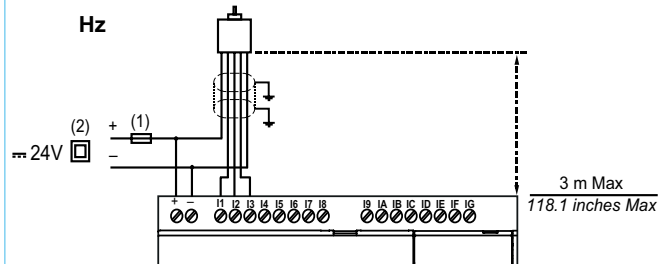
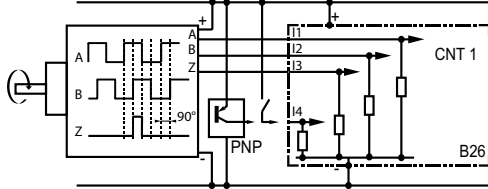

I1 ... I4 2604

+ 24 VDC

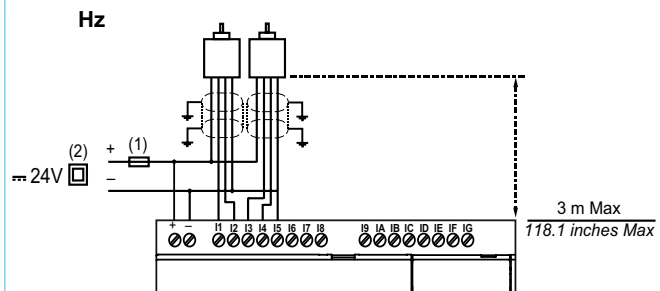
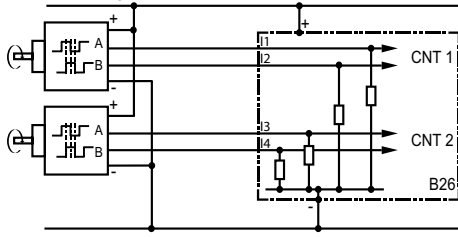

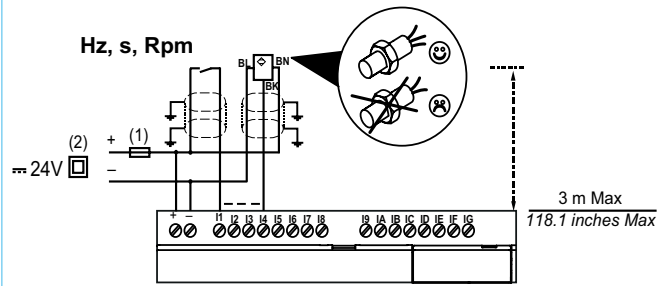
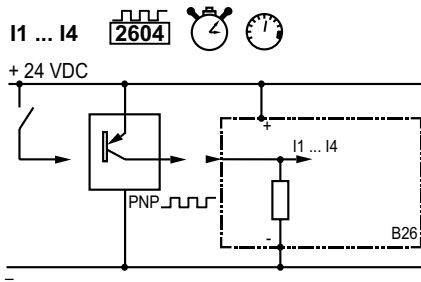

- (1) 1 A (UL248) quick-blowing fuse, circuit-breaker or circuit protector (US)
- (2) Isolating source

Outputs

O1 & O2

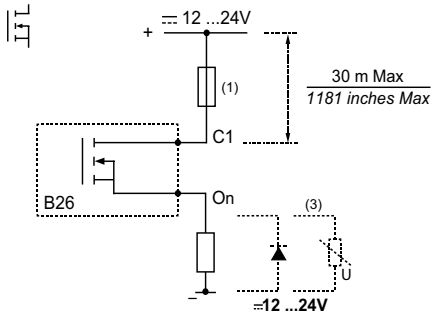

0,5 A

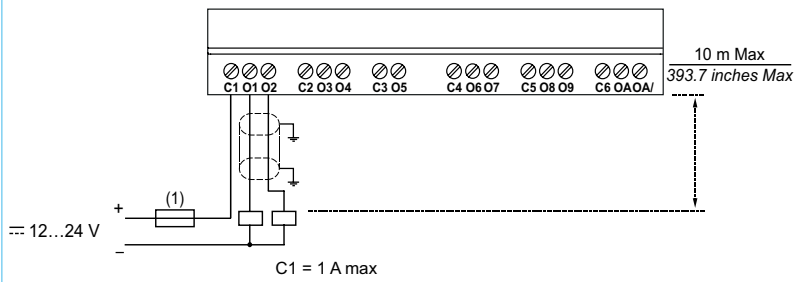

O3 ... OA

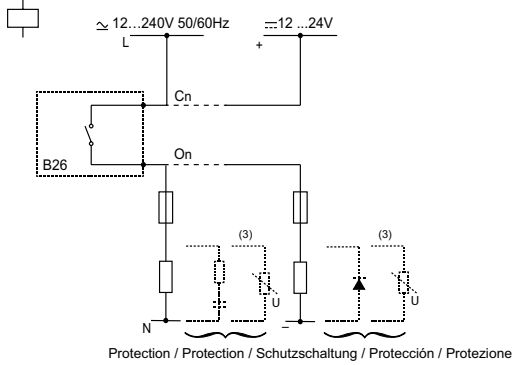

6 A, 8 A

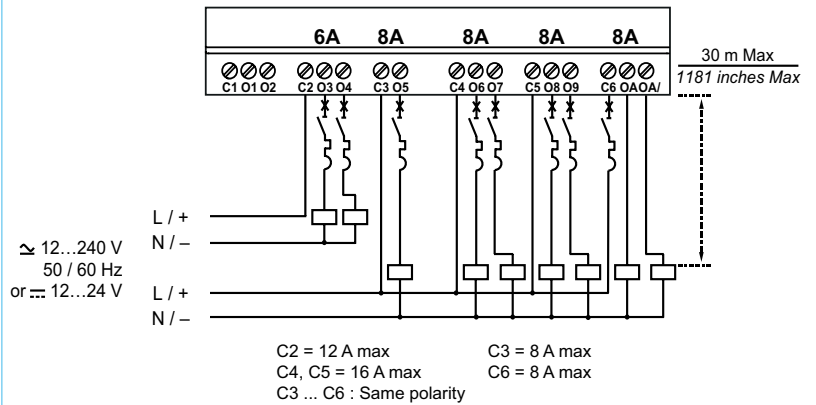

(3) Inductive load

I/O installations

