

THIS DRAWING IS UNPUBLISHED.		RELEASED FOR PUBLICATION		19			
© COPYRIGHT 1970 BY AMP INCORPORATED, HARRISBURG, PA. ALL INTERNATIONAL RIGHTS RESERVED. AMP PRODUCTS MAY BE COVERED BY U.S. AND FOREIGN PATENTS AND/OR PATENTS PENDING.							
PART NUMBER	NO. OF POS.	A	B	F	G	FINISH	
583679	1	26	.125	3.125	3.375	3.759	3
	2	3		.250	.500	.884	
	3	4		.375	.625	1.009	
	4	5		.500	.750	1.134	
	5	6		.625	.875	1.259	
	6	7		.750	1.000	1.384	
	7	8		.875	1.125	1.509	
	8	9		1.000	1.250	1.634	
	9	10		1.125	1.375	1.759	
583679	0	11		1.250	1.500	1.884	
	1	12		1.375	1.625	2.009	
	2	13		1.500	1.750	2.134	
	3	14		1.625	1.875	2.259	
	4	15		1.750	2.000	2.384	
	5	16		1.875	2.125	2.509	
	6	17		2.000	2.250	2.634	
	7	18		2.125	2.375	2.759	
	8	19		2.250	2.500	2.884	
	9	20		2.375	2.625	3.009	
2-583679	0	21		2.500	2.750	3.134	
	2	22		2.625	2.875	3.259	
	2	23		2.750	3.000	3.384	
	2	3	24	2.875	3.125	3.509	
	2	4	25	3.000	3.250	3.634	
	2	5	27	3.250	3.500	3.884	
	2	6	28	3.375	3.625	4.009	
	2	7	29	3.500	3.750	4.134	
	2	8	30	3.625	3.875	4.259	
	2	9	31	3.750	4.000	4.384	
3-583679	0	32		3.875	4.125	4.509	
	3	1	33	4.000	4.250	4.634	
	3	2	34	4.125	4.375	4.759	
	3	3	35	4.250	4.500	4.884	
	3	4	36	4.375	4.625	5.009	
	3	5	37	4.500	4.750	5.134	
	3	6	38	4.625	4.875	5.259	
	3	7	39	4.750	5.000	5.384	
	3	8	40	4.875	5.125	5.509	
	3	9	41	5.000	5.250	5.634	
4-583679	0	42		5.125	5.375	5.759	
	4	1	43	5.250	5.500	5.884	
	4	2	44	5.375	5.625	6.009	
	4	3	45	5.500	5.750	6.134	
	4	4	46	5.625	5.875	6.259	
	4	5	47	5.750	6.000	6.384	
	4	6	48	5.875	6.125	6.509	
	4	7	49	6.000	6.250	6.634	
	4	8	50	6.125	6.375	6.759	
	4	9	51	6.250	6.500	6.884	
5-583679	0	52		6.375	6.625	7.009	
5-583679	1	48		5.875	6.125	6.509	3
5-583679	2	57	.125	7.000	7.250	7.634	4

OBSOLETE 5

OBSOLETE 5

OBSOLETE 5

OBSOLETE

OBSOLETE 5

OBSOLETE 5

REVISIONS					
P	F	ZONE/LTR	DESCRIPTION	DATE	APPROVED
		J	REV PER AD1583	2/12/87	CP
		K	REV PER AD 1633	6-23-87	LB
		L	REV PER AD 1698	8-5-87	LB
		M	REV PER AD 1868	2/2/88	
		N	REV PER AD 2110	3/1/88	LB
		P	REV PER AD 2949	1/1/88	LB/HWR
		R	REV PER AD 3150	2/1/88	LB/HWR
		S	REV PER AD4165	12/89	CP
		T	REV PER AD 3493	3/90	LB DWR
		U	REV 0010-0252-93	3-8-93	LB DAM
		V	OBS PER ECN 0619-93	7-93	RAC D
		W	REV PER 0010-1602-95	1-96	P.B./
		Y	REV PER EC 0320-209-97	7-97	NS
		Y1	REVISED PER - ECO-09-026444	27NOV09	KK AEG

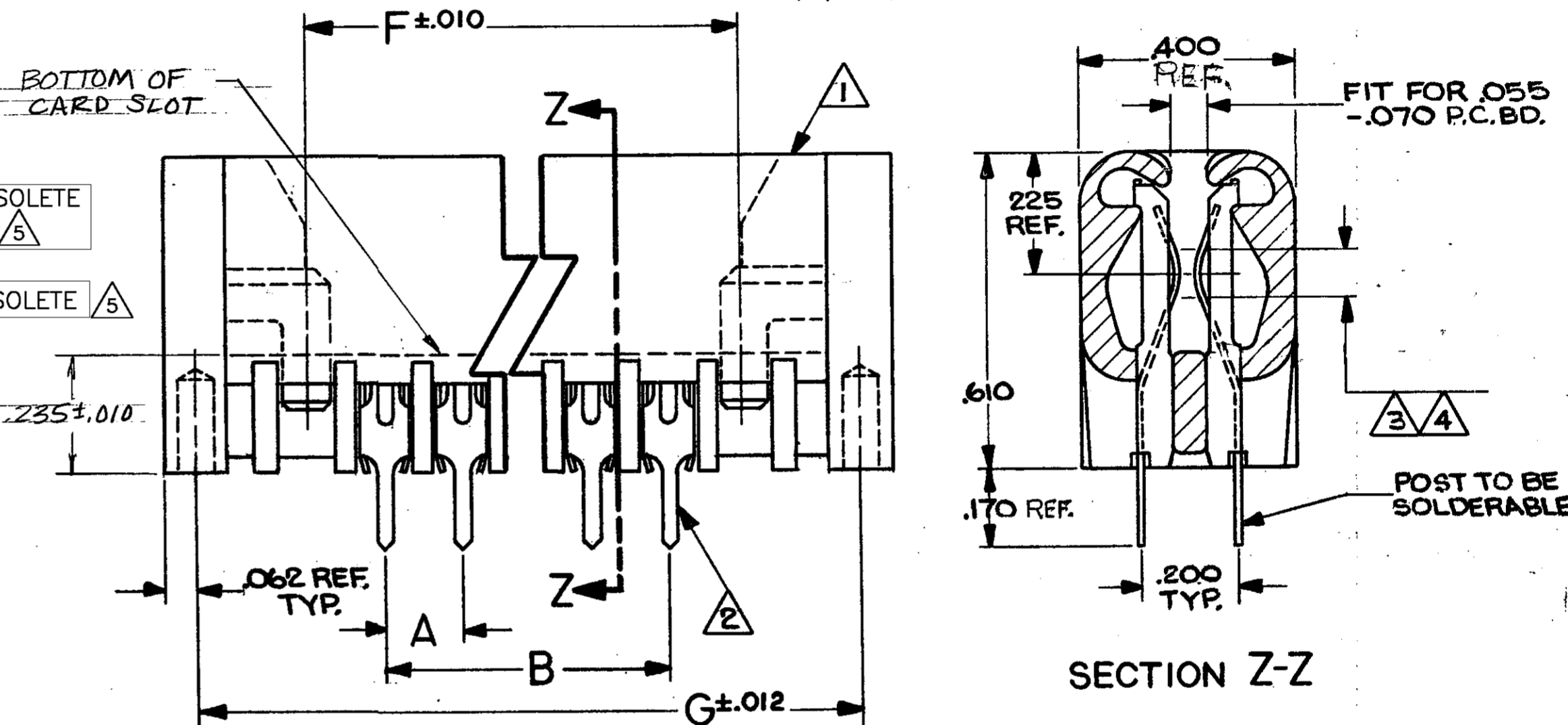

- 1 HOUSING MATERIAL : GLASS-FILLED PLYESTER, COLOR-BLACK.
- 2 CONTACT MATERIAL : PHOSPHOR BRONZE
- 3 FINISH : .000015 GOLD, SELECTIVE
- 4 FINISH : .000030 GOLD, SELECTIVE
- 5 OBSOLETE PARTS: OBSOLETE CIS STREAMLINING PER D.RENAUD/D.SINISI

UNLESS OTHERWISE SPECIFIED DIMENSIONS ARE IN INCHES. TOLERANCES ON: DECIMALS ±.005 ANGLES		CONTRACT NO DR <i>A.M. SHARPE</i> 9-9-82 CHK <i>Rayl</i> 10-11-82 APPD <i>Ray Johnston</i> 10-11-82 APPD <i>M.R. Johnson</i> 10-11-82		PART NO	
MATERIAL	FINISH	NAME ASSEMBLY, TWIN LEAF, .125¢ .010x.024 SOLDER TYPE POST, END CAP VERSION		AMP INCORPORATED Harrisburg, Pa. 17105	
1/2	3/4	SIZE C	FSCM NO 00779	DRAWING NO 583679	
OTHER APPD		SCALE 4:1	SHEET 1 OF 2		

© COPYRIGHT 1970 BY AMP INCORPORATED, HARRISBURG, PA. ALL INTERNATIONAL RIGHTS RESERVED. AMP INCORPORATED PRODUCTS COVERED BY U. S. AND FOREIGN PATENTS AND/OR PATENTS PENDING.

REVISIONS					
P/ F	ZONE	LTR	DESCRIPTION	DATE	APPROVED
			SEE SHEET 1		

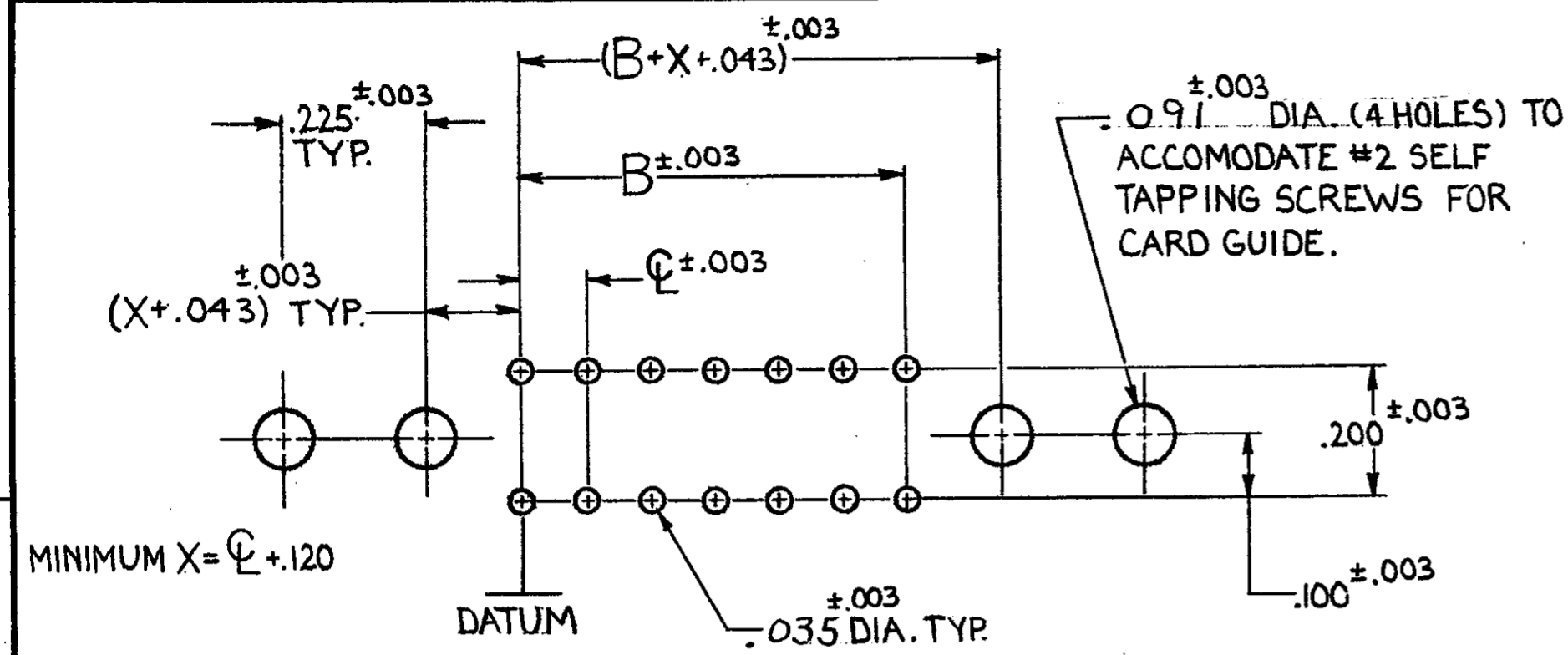

BOARD LAYOUT FOR USE WITH AMP CARD GUIDE PART NO. 583671

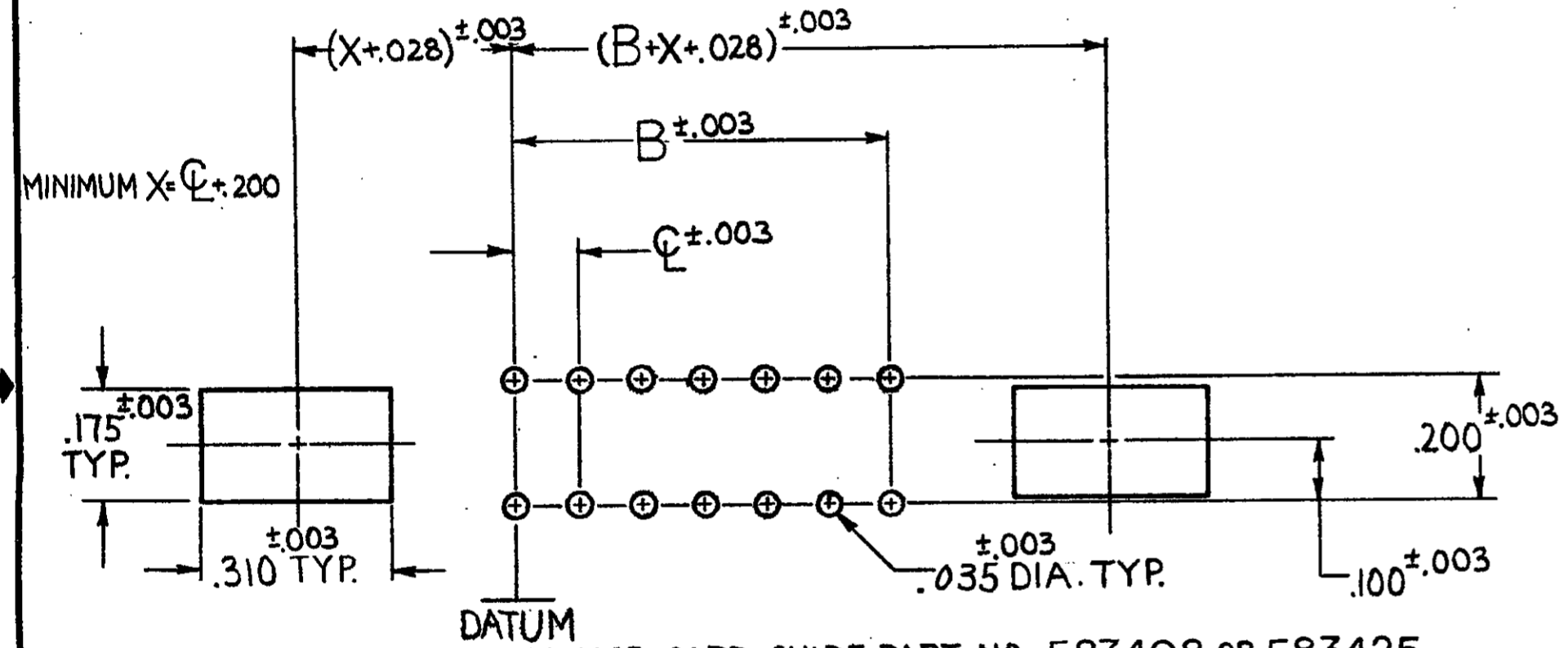

BOARD LAYOUT FOR USE WITH AMP CARD GUIDE PART NO. 583408 OR 583425

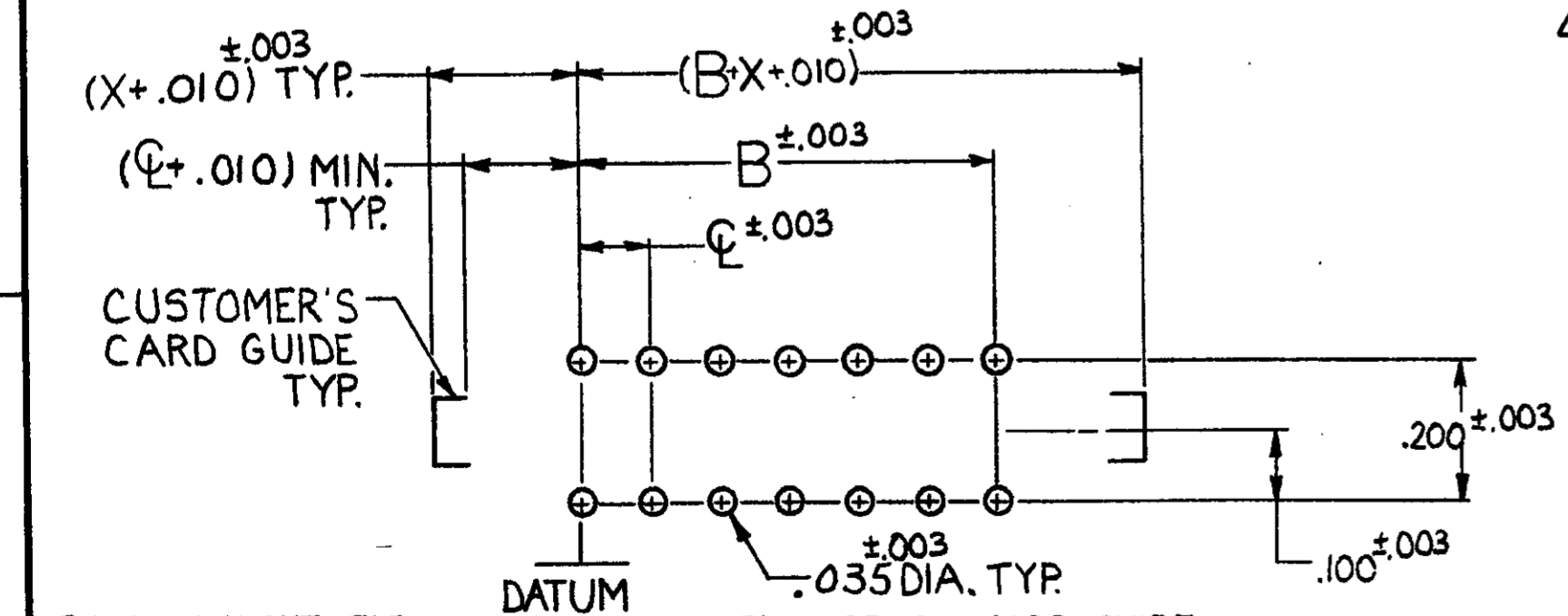

BOARD LAYOUT FOR USE WITH CUSTOMER SUPPLIED CARD GUIDE.

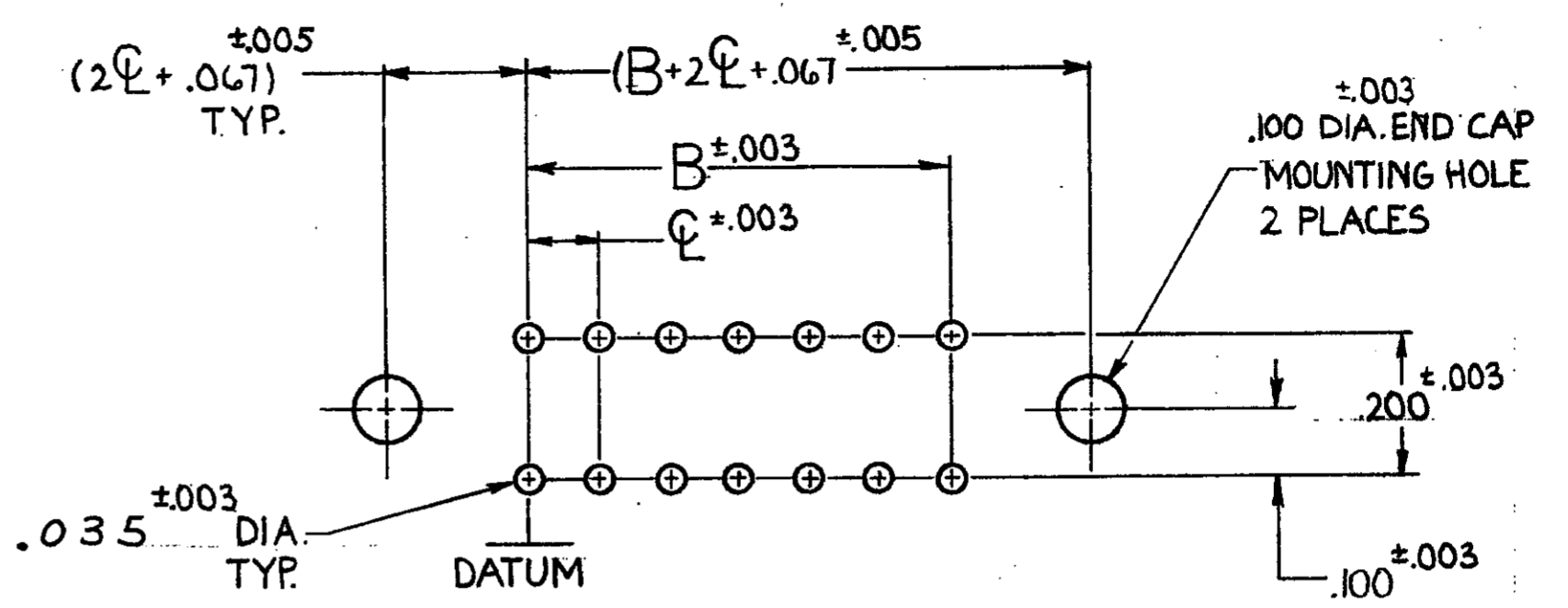

BOARD LAYOUT FOR USE WITH END CAP

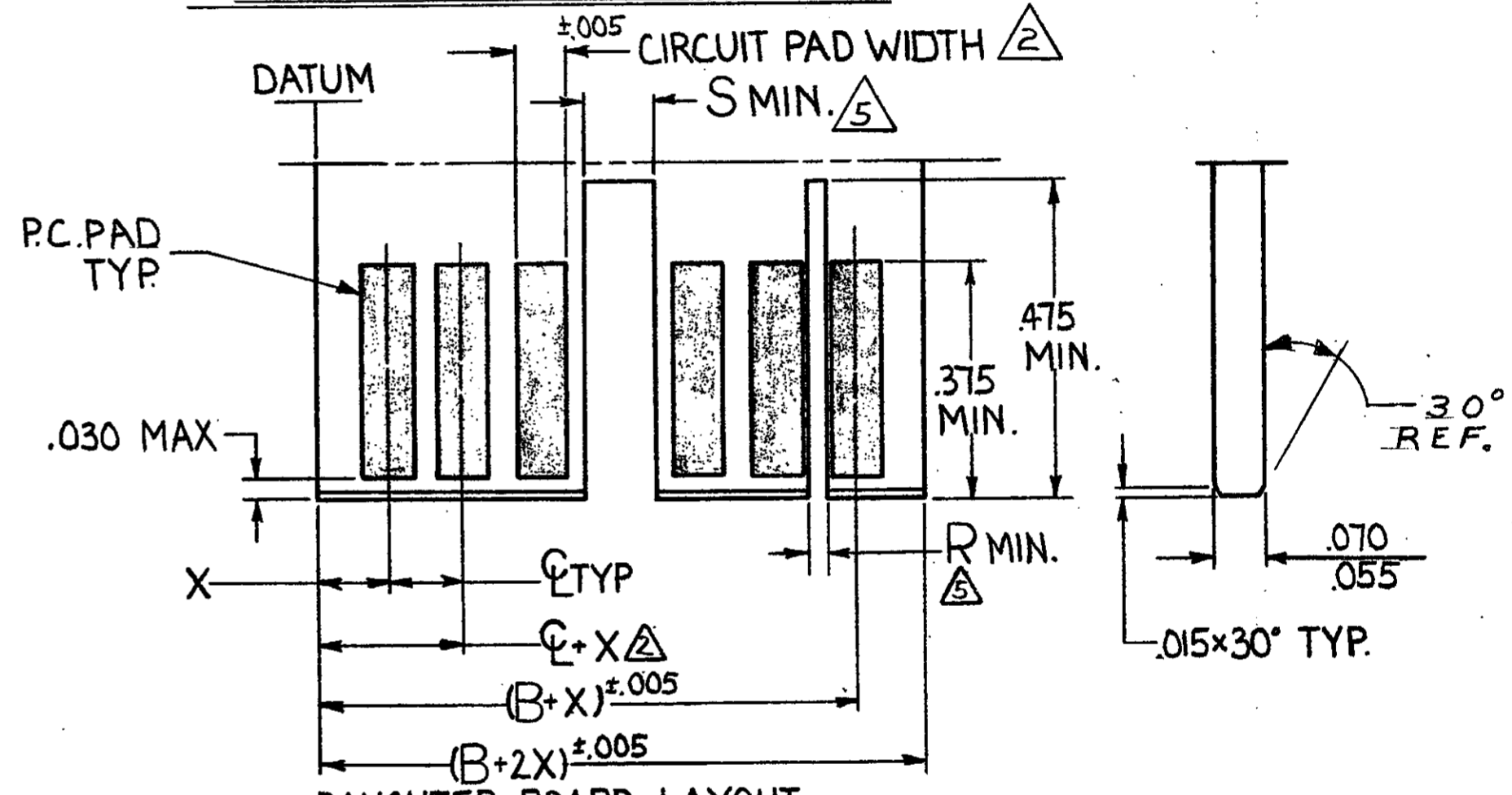

DAUGHTER BOARD LAYOUT

- MAX. ALLOWABLE WARPAGE OF MOTHER BOARD NOT TO EXCEED .005/INCH. MAX. ALLOWABLE BOW OF DAUGHTER BOARD NOT TO EXCEED .010/INCH. THICKNESS OF MOTHER BOARD IS .062 FOR DOUBLE SLOTTED CARD GUIDES AND .104 MAX. FOR ALL OTHER MOUNTING CONDITIONS.
- EACH PAD LOCATION INCREASES BY  $C \pm .005$  WITH A NON-CUMULATIVE TOLERANCE OF  $\pm .005$ .  
CIRCUIT PAD WIDTH - .045 FOR .100C, .072 FOR .150C, .072 FOR .125C, .080 FOR .156C
- C INCREMENTS ON MOTHER BOARD HAVE  $\pm .003$  NON-CUMULATIVE TOLERANCE.
- X IS A CUSTOMER CONTROLLED DIMENSION EXCEPT FOR END CAP ASSEMBLIES WHERE  $X = C - .008$
- THE SLOT FOR INTER-CONTACT KEYING PLUGS MUST BE CENTERED BETWEEN THE PRINTED CIRCUIT PADS, WHILE THE SLOT FOR ON-CONTACT KEYING PLUGS MUST BE CENTERED ON THE AREA OF A PRINTED CIRCUIT PAD.

INTER-CONTACT KEYING PLUG	R	FOR CENTER LINE SPACING	ON-CONTACT KEYING PLUG	S	FOR CENTER LINE SPACING
530030-1	.050	.125-.150-.156	583714-1	.129	.100-.125
530030-2	.090	.100	583714-2	.160	.150-.156

UNLESS OTHERWISE SPECIFIED DIMENSIONS ARE IN INCHES. TOLERANCES ON: DECIMALS ± ANGLES ±		CONTRACT NO 10-6-82	AMP INCORPORATED Harrisburg, Pa.
MATERIAL	DR M. Smith	NAME HOUSING ASSEMBLY TWIN LEAF CONNECTOR .125 CENTERS	
FINISH	CHK Ray Johnston	DATE 10-11-82	SIZE CODE IDENT NO DRAWING NO C 00779 583679
	APPD Ray Johnston	DATE 10-11-82	SCALE # SHEET 2 OF 2
	APPD MRT	DATE 10-12-82	