

Control board for automotive motor control applications based on SPC58NN84E7



Features

- Control board with SPC58NN84E7 microcontroller in eLQFP176 package (AEC-Q100 qualified and ASIL-D of ISO 26262)
- SPC5 studio Motor Control software tool support
- MC connector compatible with all ST motor control power boards for
- CAN-FD and UART interfaces
- HALL, Encoder and Resolver sensor inputs
- Suitable for applications implementing field oriented control (FOC)
- Analog input/output with active filters and compatible with a dedicated daughter board for resolver reading

Description

This control board is designed for high voltage motor control applications like traction inverters. The board hosts several connectors offering a wide range of external connection options for digital and analog inputs and outputs with optimized filters for signal conditioning.

The control board can be powered independently via its power supply connector or it can be supplied by any power board through the MC connector. The board includes a potentiometer and a user button for further evaluation and application development support.

Product summary	
Control board for automotive motor control applications based on SPC58NN84E7	STEVAL-TTM004V1
32-bit Power Architecture MCU for High Performance Applications	SP58NN84E7

Figure 1. STEVAL-TTM004V1 - board schematics (1 of 4)

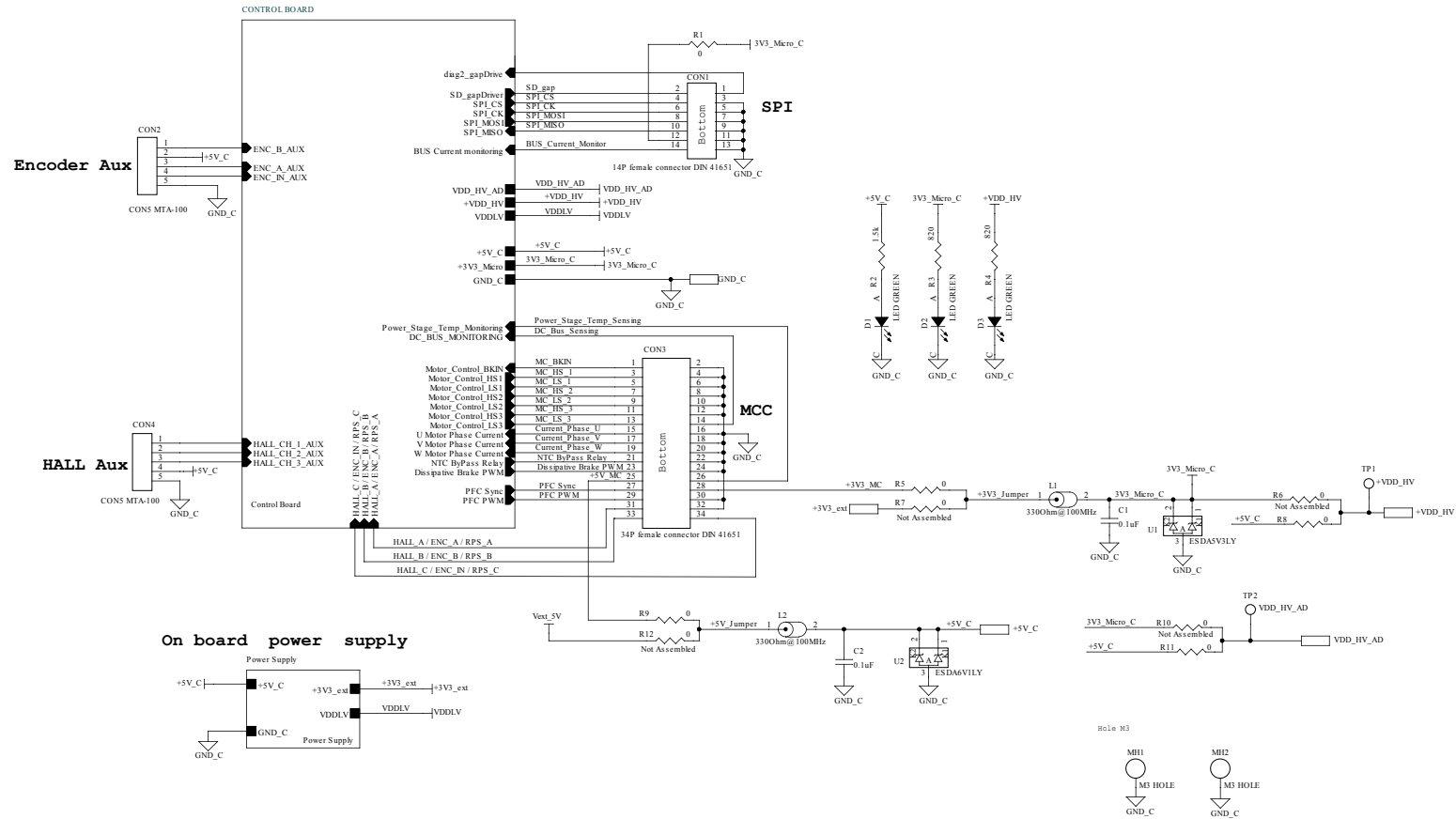

Figure 2. STEVAL-TTM004V1 - board schematics (2 of 4)

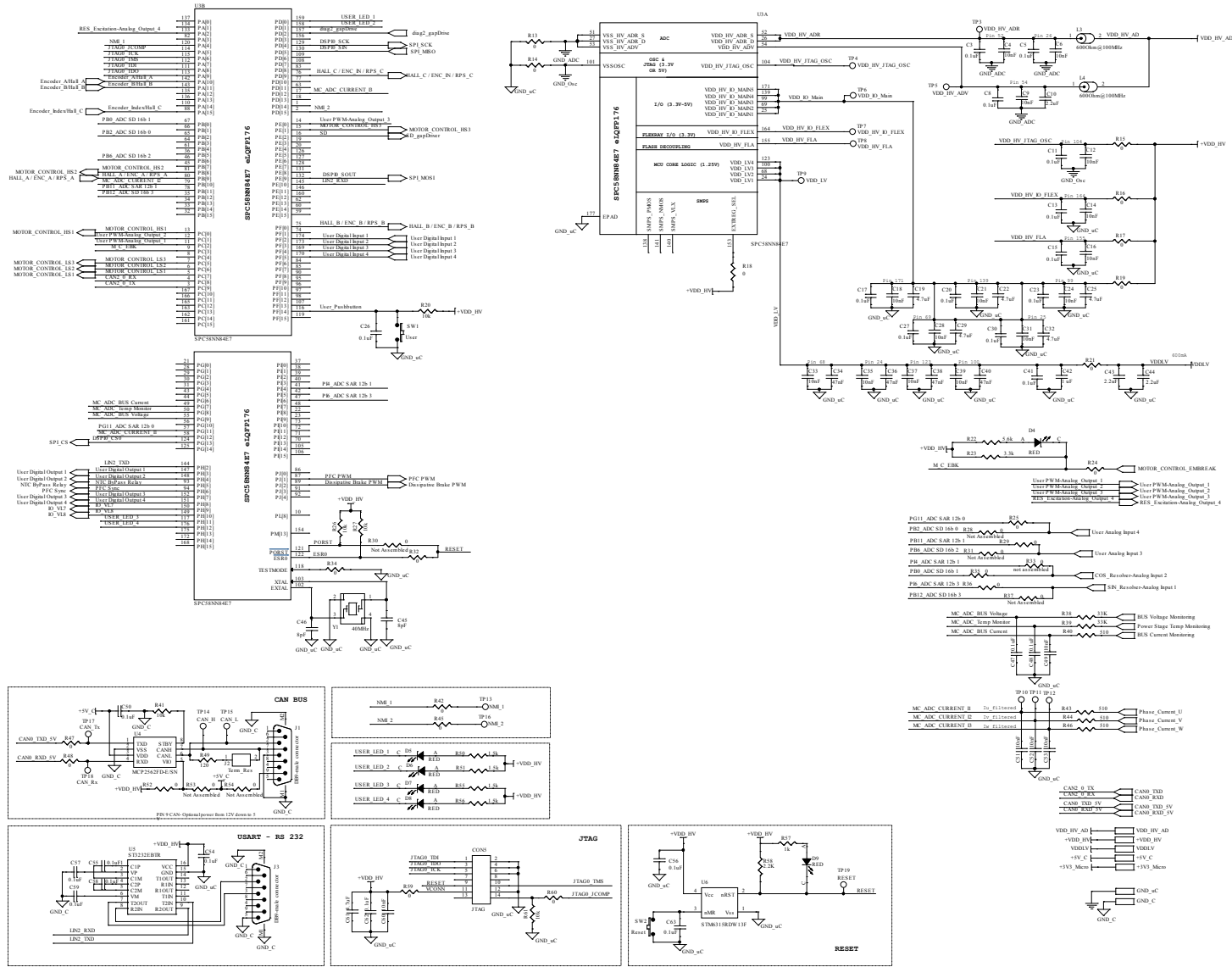

Figure 3. STEVAL-TTM004V1 - board schematics (3 of 4)

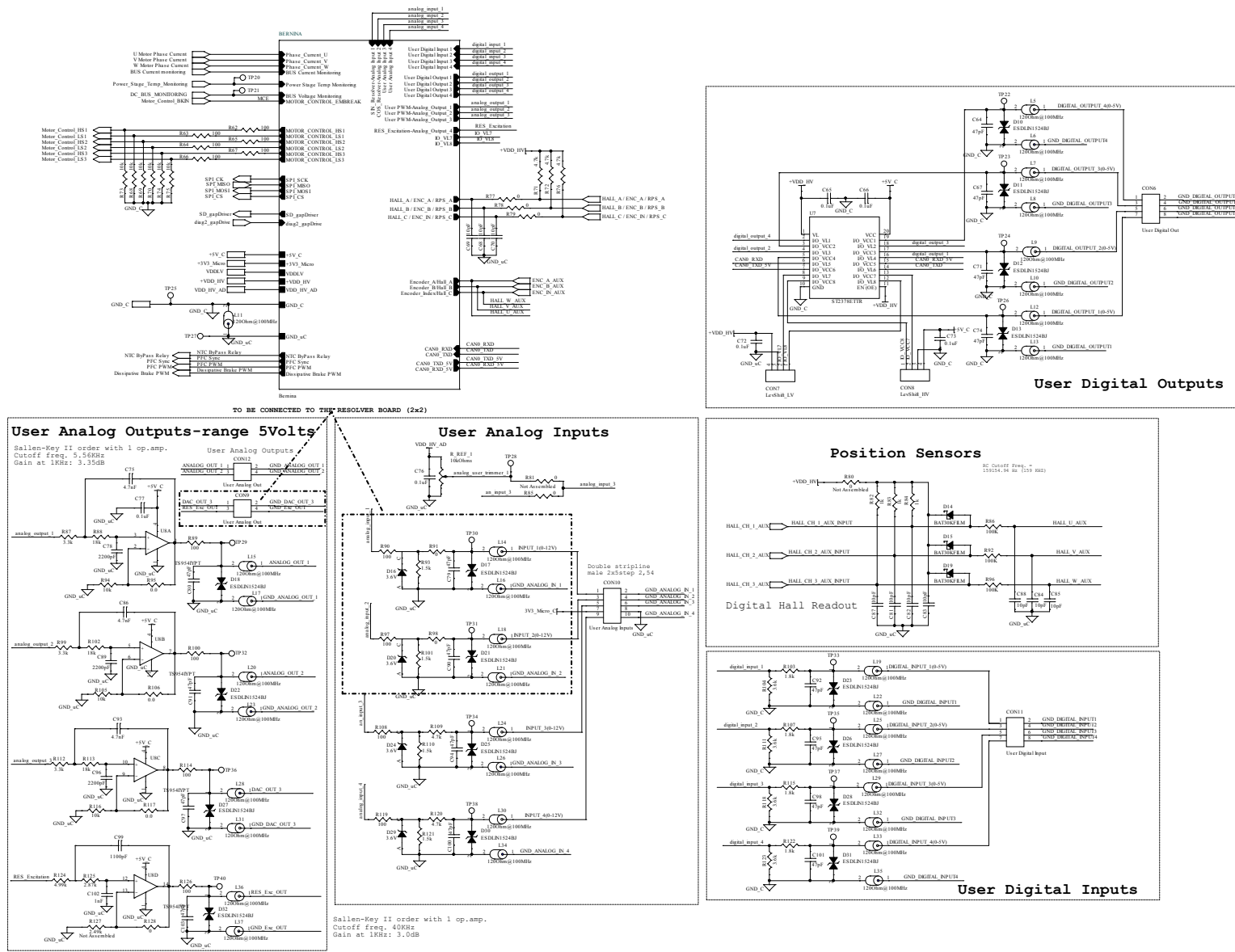
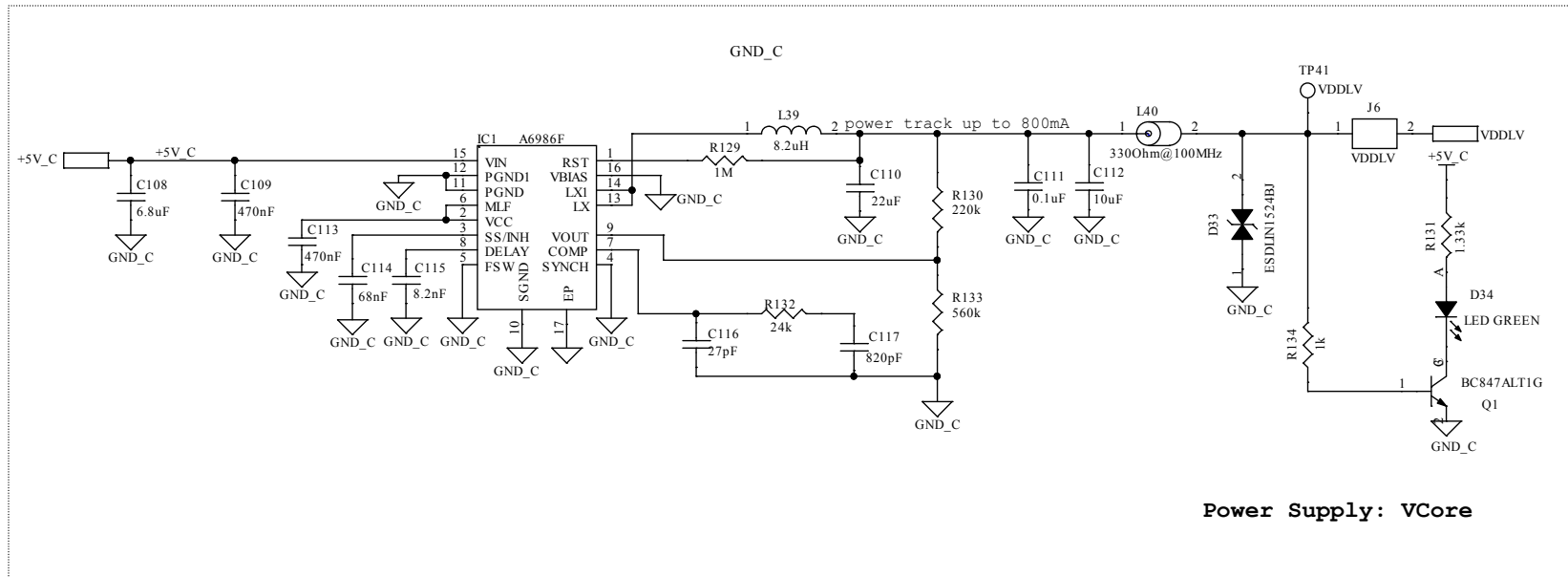
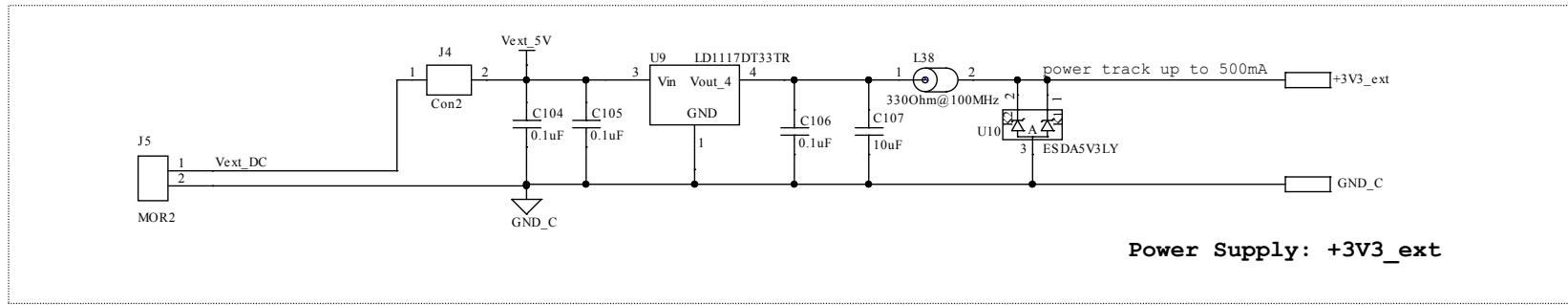

Figure 4. STEVAL-TTM004V1 - board schematics (4 of 4)



Revision history

Table 1. Document revision history

Date	Version	Changes
23-Jun-2020	1	Initial release.

IMPORTANT NOTICE – PLEASE READ CAREFULLY

STMicroelectronics NV and its subsidiaries (“ST”) reserve the right to make changes, corrections, enhancements, modifications, and improvements to ST products and/or to this document at any time without notice. Purchasers should obtain the latest relevant information on ST products before placing orders. ST products are sold pursuant to ST’s terms and conditions of sale in place at the time of order acknowledgement.

Purchasers are solely responsible for the choice, selection, and use of ST products and ST assumes no liability for application assistance or the design of Purchasers’ products.

No license, express or implied, to any intellectual property right is granted by ST herein.

Resale of ST products with provisions different from the information set forth herein shall void any warranty granted by ST for such product.

ST and the ST logo are trademarks of ST. For additional information about ST trademarks, please refer to www.st.com/trademarks. All other product or service names are the property of their respective owners.

Information in this document supersedes and replaces information previously supplied in any prior versions of this document.

© 2020 STMicroelectronics – All rights reserved