

FCM8201

3-Phase Sinusoidal Brushless DC Motor Controller

Features

- Supports Space Vector Modulation (SVM)
- Supports Sine-Wave & Square-Wave Solutions
- Built-in Clock Generator
- Built-in Error Amplifier for Torque Loop Control
- Direct Duty Control
- Square-Wave 120°, Sine-Wave 180° Turn-on
- PLL Angle Detection (Hall Sensors)
- Programmable Current Leading Phase
- Serial Interface (SPI)
- Two Operation Modes (Stand-Alone Operation or Controlled through SPI)
- Programmable Soft-Switching (Dead-Time)
- Synchronous Rectifying
- Over-Voltage and Under-Voltage Protections
- Motor & Power Transistor Over-Voltage Protections
- Three Levels of Over-Current Protection (OCP)
- Programmable OC Timer
- Over-Temperature Protection (OTP)

Description

FCM8201 is a three-phase sinusoidal Brushless DC (BLDC) motor or Permanent Magnet Synchronous Motor (PMSM) controller. It comes with the advanced Hall sensor design. Using the Hall sensor signals, the control system is able to execute the PWM commutation by switching the three-phase inverter. There are two PWM modes for selection: Sine-Wave Mode and the Square-Wave Mode. Square-Wave Mode includes PWM-PWM and PWM-ON approaches to improve the efficiency of the motor drive. Protection functions including over-voltage, over-current, over-temperature, and short circuit prevent the control circuits and the motor from being damaged, particularly under stressed applications and demanding environments. Information about voltage, current, and temperature is accessible through the SPI interface.

FCM8201 can be operated stand-alone or worked with microcontrollers for advanced BLDC motor control.

Applications

- BLDC Motor or PMSM Control
- Low-Noise Motor Applications
- Fan, Pump, Tools, etc.

Ordering Information

Part Number	Operating Temperature Range	Package	Packing Method
FCM8201QY	-40°C to 125°C	32-Lead, LQFP, JEDEC MS-026, Variation BBA, 7 mm Square	Tray

Typical Application Circuits

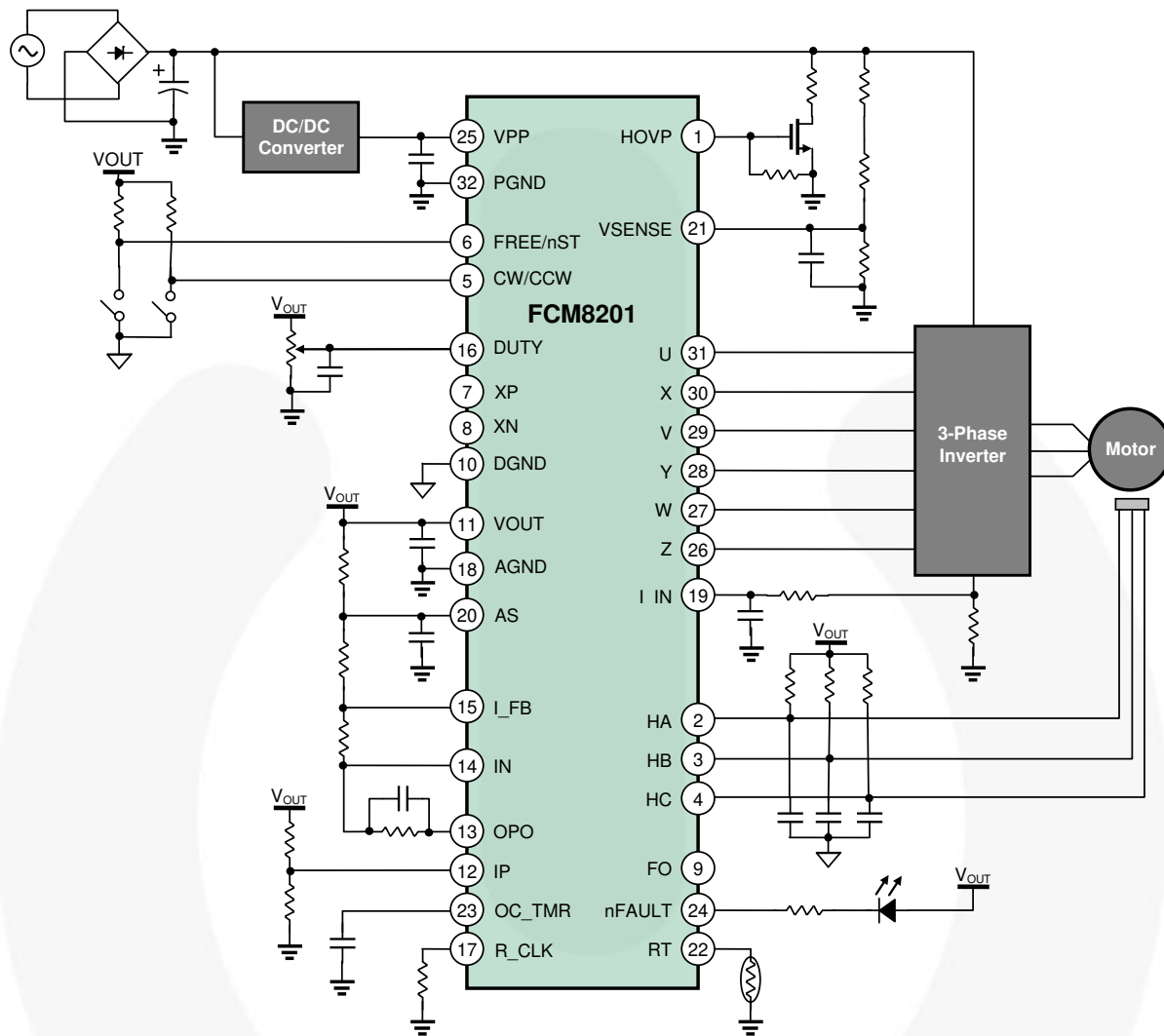

Figure 1. Stand-Alone Application

Typical Application Circuits (Continued)

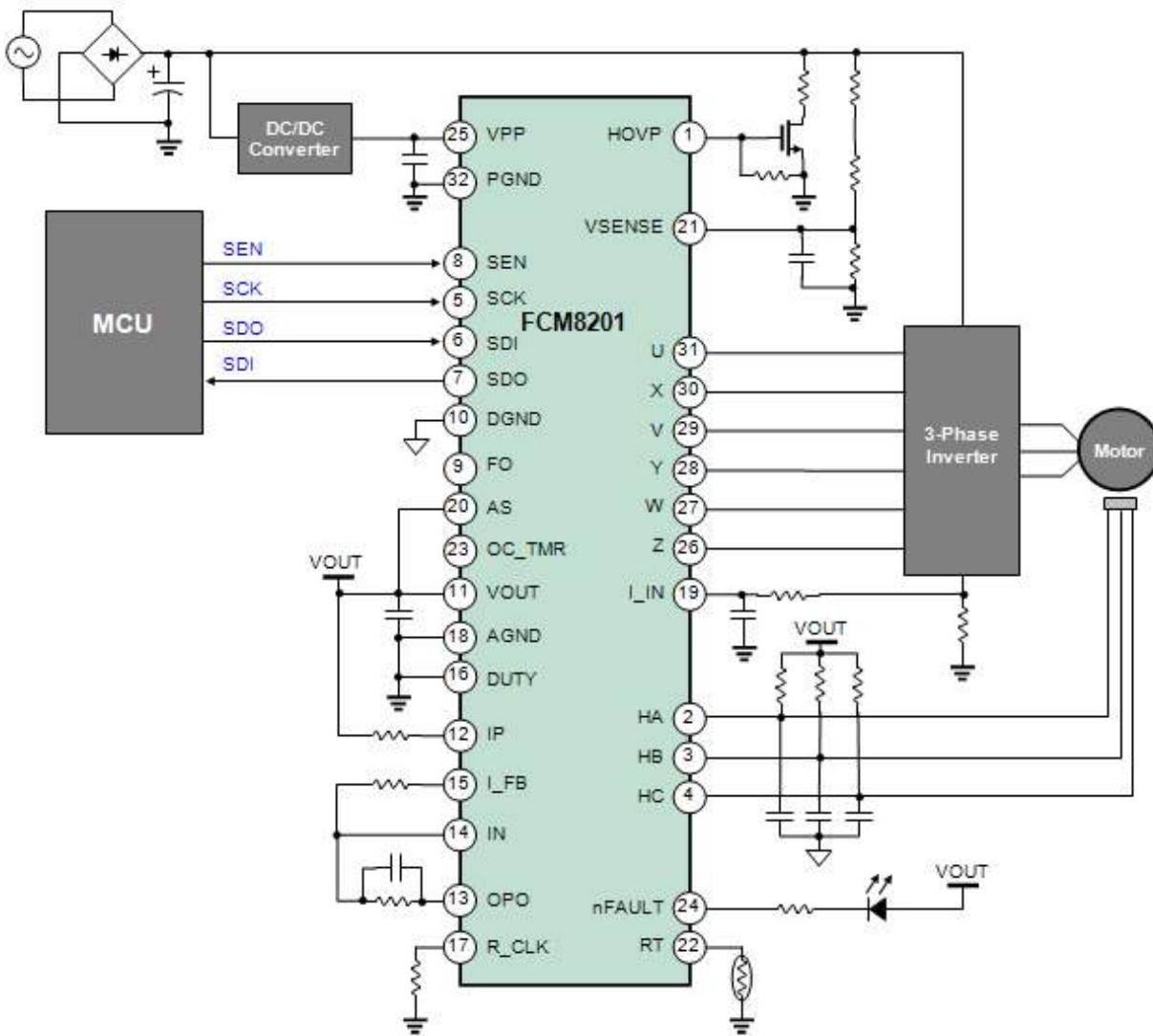

Figure 2. SPI Application

Block Diagram

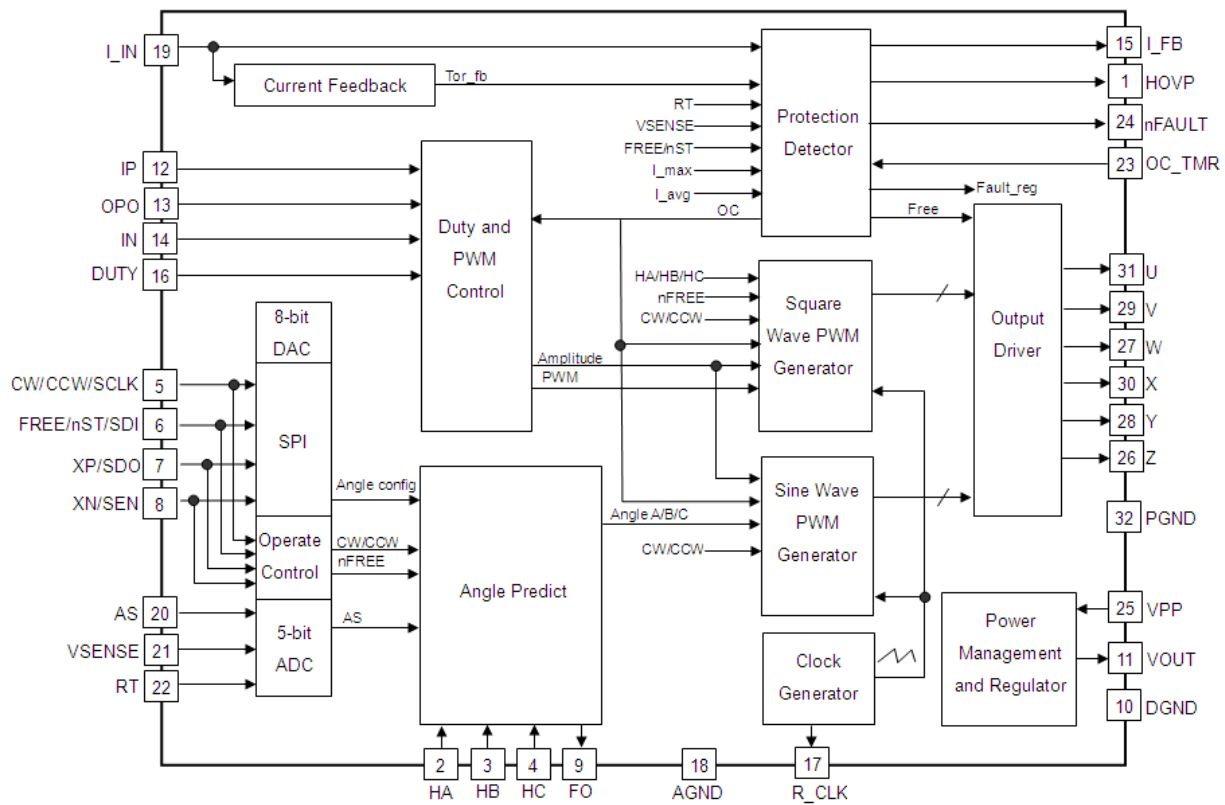
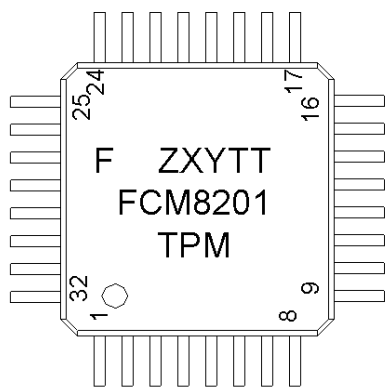

Figure 3. System Block Diagram

Marking Information



- F- Fairchild Logo
- Z- Plant Code
- X- 1-Digit Year Code
- Y- 1-Digit Week Code
- TT- 2-Digit Die Run Code
- T- Package Type (Q=LQFP)
- P- Y=Green Package
- M- Die Run Code

Figure 4. Top Mark

Pin Configuration

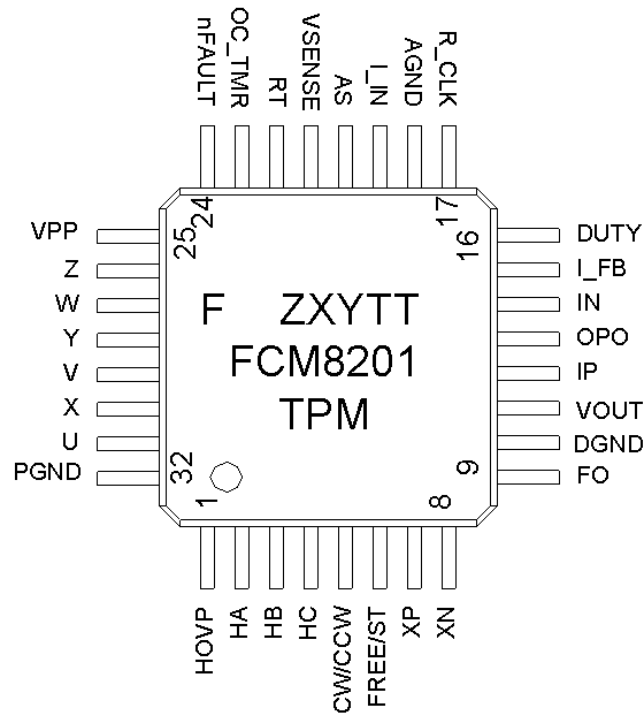

Figure 5. Pin Configuration

Pin Definitions

Pin #	Name	Description
1	HOVP	Motor Drive Over-Voltage Protection Output. It can be connected to an external power transistor for discharging the back EMF.
2	HA	Hall A Sensor Input. Phase-U magnetic field detection.
3	HB	Hall B Sensor Input. Phase-V magnetic field detection.
4	HC	Hall C Sensor Input. Phase-W magnetic field detection.
5	CW/CCW	Direction Control Input. Designed for stand-alone operation. HIGH: CW, LOW: CCW.
	SCLK	Serial Clock Input. Designed for SPI operation.
6	FREE/ST	Free and Start Control Input. Designed for stand-alone operation. HIGH: Free, LOW: Start.
	SDI	Serial Data Input. Designed for SPI operation.
7	XP	Interface Selection P (Open-Drain). Designed to configure the pin #5~8 work on stand-alone or SPI operation.
	SDO	Serial Data Output, (Open-Drain). Designed for SPI operation.
8	XN	Interface Selection N (Open-Drain). Designed to configure the pin #5~8 work on stand-alone or SPI operation.
	SEN	SPI Enable (Open-Drain). Designed for SPI operation. HIGH: SPI disable, LOW: SPI enable.

Continued on the following page...

Pin Definitions (Continued)

Pin #	Name	Description
9	FO	Revolution Pulse Output. Pulses per revolution= motor poles \div 2 \times 3.
10	DGND	Digital Ground
11	VOUT	Voltage Regulator Output. A 0.1 μ F (minimum) capacitor should be connected between this pin and ground.
12	IP	Positive Input of Torque Error Amplifier
13	OPO	Output of Torque Error Amplifier
14	IN	Negative Input of Torque Error Amplifier
15	I_FB	Current Feedback Output
16	DUTY	PWM Duty Control Input. Designed to directly control the PWM duty cycle in stand-alone operation.
17	R_CLK	External Resistor of Clock Generator. Designed for determining the frequency of the internal clock generator.
18	AGND	Analog Ground
19	I_IN	Current Feedback Input
20	AS	Angle Shift Input. Designed for correcting the lead angle of PWM output signals. The range is from 0° to 60° related to the induced magnetic voltage.
21	VSENSE	Motor Drive Voltage-Sensing Resistor. Designed for determining the voltage level of over-voltage protections.
22	RT	Thermistor Voltage Input. Connect to a NTC (Negative Temperature Coefficient) thermistor for the over-temperature protection.
23	OC_TMR	Overload Time-Out Programmable Input. Connect to a capacitor for determining the time delay of overload protection.
24	nFAULT	Fault Flag. Open-drain output, LOW: system failure.
25	VPP	Supply Voltage Input
26	Z	PWM Output of W-Phase Low Side
27	W	PWM Output of W-Phase High Side
28	Y	PWM Output of V-Phase Low Side
29	V	PWM Output of V-Phase High Side
30	X	PWM Output of U-Phase Low Side
31	U	PWM Output of U-Phase High Side
32	PGND	High-Voltage Ground

Absolute Maximum Ratings

Stresses exceeding the absolute maximum ratings may damage the device. The device may not function or be operable above the recommended operating conditions and stressing the parts to these levels is not recommended. In addition, extended exposure to stresses above the recommended operating conditions may affect device reliability. The absolute maximum ratings are stress ratings only.

Symbol	Parameter	Min.	Max.	Unit
V_{VPP}	Supply Voltage	0	30	V
θ_{JA}	Thermal Resistance, Junction-to-ambient		82	°C/W
θ_{JC}	Thermal Resistance, Junction-to-case		29	°C/W
T_J	Junction Temperature		+150	°C
ESD	Human Body Model, JESD22-A114		2	kV
	Charged Device Model, JESD22-C101		1	

Recommended Operating Conditions

The Recommended Operating Conditions table defines the conditions for actual device operation. Recommended operating conditions are specified to ensure optimal performance to the datasheet specifications. Fairchild does not recommend exceeding them or designing to Absolute Maximum Ratings.

Symbol	Parameter	Conditions	Min.	Typ.	Max.	Unit
T_A	Operating Ambient Temperature		-40		+125	°C
V_{PP}	Supply Voltage		10.0	12.0	17.0	V
f_{SYS}	System Clock		0.96	1.28	1.92	MHz
R_{CLK}	Clock Generator External Resistor			12		k Ω
R_{I_IN}	I_IN Bias Resistor			10		k Ω

Electrical Characteristics

$V_{PP} = 12\text{ V}$ and $T_A = 25^\circ\text{C}$ unless otherwise noted.

Symbol	Parameter	Conditions	Min.	Typ.	Max.	Units
V_{PP} Section						
V _{VPP_ON}	Turn-On Threshold Voltage		8.5	9.0	9.5	V
V _{VPP_OFF}	Turn-Off Threshold Voltage		7.5	8.0	8.5	V
I _{DD_OP}	Operating Supply Current	V _{PP} = 12 V, f _{SYS} = 1.28 MHz	4.0	5.0	6.5	mA
Voltage Regulator Section						
V _{VOUT}	Regulator Output Voltage	Output Current 5 mA	4.9	5.2	5.5	V
I _{VOUT}	Regulator Output Current	V _{VOUT} = 5.2 V			10	mA
C _{VOUT}	Regulator External Capacitor		0.1			μF
Digital I/O Section						
V _{IH_HALL}	Hall Signals Input High Level		4.0			V
V _{IL_HALL}	Hall Signals Input Low Level				1.0	V
V _{HYS_HALL}	Hall Signals Hysteresis Voltage		2.0	2.5	3.0	V
T _{DEB_HALL}	Hall Signals Debounce Time			5		μs
V _{IH_SPI}	SPI Signals Input High Level		2.0		5.3	V
V _{IL_SPI}	SPI Signals Input Low Level		-0.3	0.8	1.2	V
V _{OH_SPI}	SPI Signals Output High Level	I _O = 4 mA	4			V
V _{OL_SPI}	SPI Signals Output Low Level	I _O = 4 mA			1	V
R _{DIO_UP}	Digital I/O Internal Pull High Resistor		150	200	250	kΩ
High-Voltage I/O Section						
V _{OH_PWM}	PWM Signals Output High Level (U/V/W/X/Y/Z)	V _{PP} = 12 V, I _O = 4 mA	10			V
V _{OL_PWM}	PWM Signals Output Low Level (U/V/W/X/Y/Z)	V _{PP} = 12 V, I _O = 4 mA			1	V
V _{OH_HOVP}	HOVP Output High Level	V _{PP} = 12 V, I _O = 1 mA	9.0	9.7	10.0	V
V _{OL_HOVP}	HOVP Output Low Level	V _{PP} = 12 V, I _O = 1 mA			1	V
PWM Control Section						
V _{fd}	Full Duty Voltage of DUTY Pin		4.0	4.3	4.6	V
V _{zd}	Zero Duty Voltage of DUTY Pin			0.7		V
t _{PWM_MIN}	PWM Minimum On Time	R_CLK = 12 kΩ		1		μs
t _{DEAD0}	PWM Dead Time 0	DT[1:0] / PWM_REG = 00 (Default Value)	2.15	2.72	3.45	μs
t _{DEAD1}	PWM Dead Time 1	DT[1:0] / PWM_REG = 01	1.45	1.95	2.45	μs
t _{DEAD2}	PWM Dead Time 2	DT[1:0] / PWM_REG = 10	3.35	3.96	4.65	μs
t _{DEAD3}	PWM Dead Time 3	DT[1:0] / PWM_REG = 11	2.75	3.34	4.05	μs
REG _{zd}	Zero Duty Value of DUTY_REG and IP_REG		0x00		0x07	
f _{PWM_20K}	PWM Frequency 20 kHz	R_CLK = 12 kΩ	18.5	20.0	21.5	kHz
I _{SOURCE_OPO}	Current Source Capability of OPO Pin	IP = 5 V, IN = 0 V, OPO = 0 V	4.0	5.0	6.0	mA
I _{SINK_OPO}	Current Sink Capability of OPO Pin	IP = 0 V, IN = 5 V, OPO = 5 V	-4.0	-5.0	-6.0	mA
A _{VERR}	Gain of Torque Error Amplifier			60		dB
GBW _{ERR}	Unit-Gain Bandwidth of Torque Error Amplifier			10		MHz

Continued on the following page...

Electrical Characteristics (Continued)V_{PP} = 12 V and T_A = 25°C unless otherwise noted.

Symbol	Parameter	Conditions	Min.	Typ.	Max.	Units
Sine Wave PWM Generator						
V _{SIN_ENA}	Sine Wave Enable Threshold of DUTY Pin			0.75		V
V _{SIN_DIS}	Sine Wave Disable Threshold of DUTY Pin			0.65		V
t _{SIN_ENA}	Sine Wave Enable Debounce Time			1		ms
t _{SIN_DIS}	Sine Wave Disable Debounce Time			100		ms
Over-Current Protections Section						
V _{OCP_SH}	Short-Circuit Current Protection Threshold Voltage			2.5		V
V _{OCP_CYC}	Cycle-by-Cycle Current Protection Threshold Voltage			1.5		V
V _{OCP_OL}	Overload Current Protection Threshold Voltage			1.4		V
V _{OC_TMR}	OC_TMR Threshold Voltage			2.5		V
I _{TMR_CHG}	OC_TMR Charge Current	OC_TMR = 0 V	30	40	50	μA
I _{TMR_DIS}	OC_TMR Discharge Current	OC_TMR = 5 V	5	10	15	μA
I _{BIAS_I_IN}	Bias Current of I_IN	R _{I_IN} = 10 kΩ	40	50	60	μA
I _{O_I_FB}	I_FB Output Current			0.5		mA
G _{I_FB}	I_FB Output Gain			8		
Over/Under-Voltage Protections (OVP/UVP) Section						
V _{OV_VPP}	System OVP Threshold Voltage			18		V
V _{OV_VPP_RLS}	System OVP Release Voltage			17		V
t _{OV_VPP}	System OVP Debounce Time			100		μs
V _{UV_VPP}	System UVP Threshold Voltage		7.5	8.0	8.5	V
V _{UV_VPP_RLS}	System UVP Release Voltage		8.5	9.0	9.5	V
V _{UV_VOUT}	V _{OUT} UVP Threshold Voltage			4		V
V _{UV_VOUT_RLS}	V _{OUT} UVP Release Voltage			4.5		V
V _{OV_MOTOR}	Motor Drive Voltage OVP Threshold Voltage		4.3	4.5	4.8	V
V _{RL_MOTOR}	Motor Drive Voltage OVP Release Voltage			4.0		V
Over-Temperature Protection (OTP) Section						
V _{RT}	OTP Threshold Voltage		0.9	1.0	1.1	V
V _{RT_RLS}	OTP Release Voltage		1.15	1.20	1.25	V
I _{RT}	RT Pin Source Current		40	50	60	μA
Pins Open/Short Protection Section						
V _{SHORT}	Pins Short Protection Level	R_CLK Pin		0.2		V
V _{OPEN}	Pins Open Protection Level	R_CLK and RT Pins	4.6	4.8	5.2	V

Typical Performance Characteristics

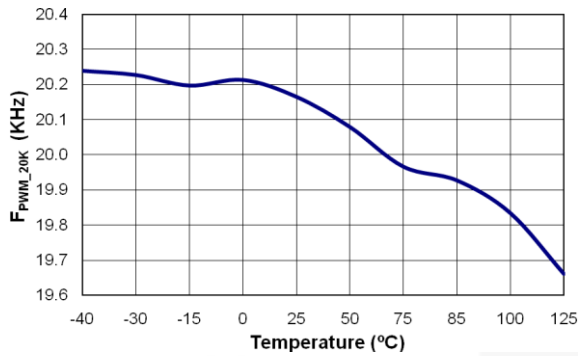

Figure 6. PWM Frequency 20 kHz (f_{PWM_20K}) vs. Temperature

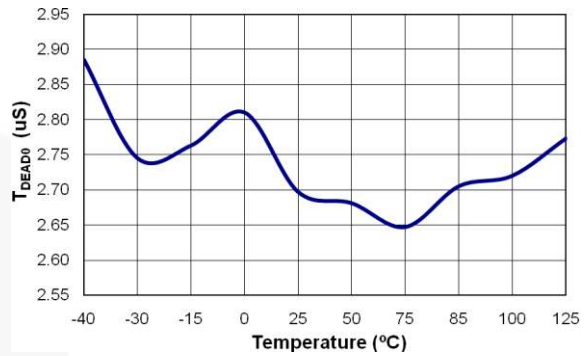

Figure 7. PWM Dead Time 2 μ s (t_{DEAD0}) vs. Temperature

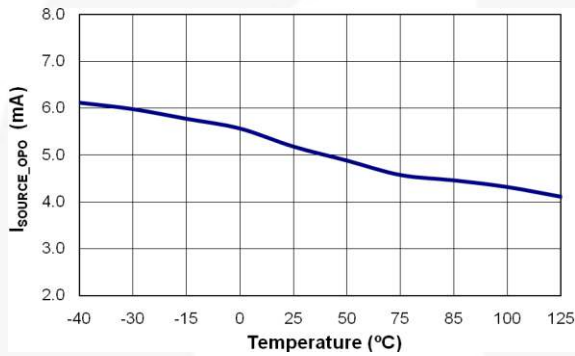

Figure 8. OPO Current Source (I_{SOURCE_OPO}) vs. Temperature

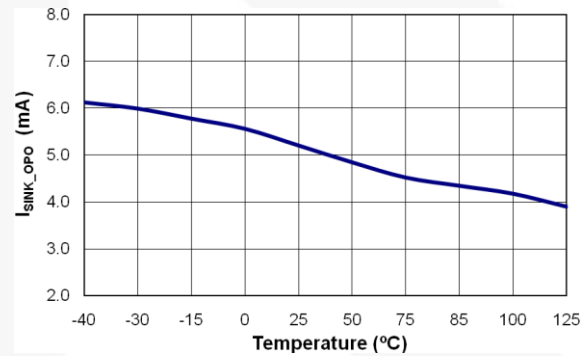

Figure 9. OPO Current Sink (I_{SINK_OPO}) vs. Temperature

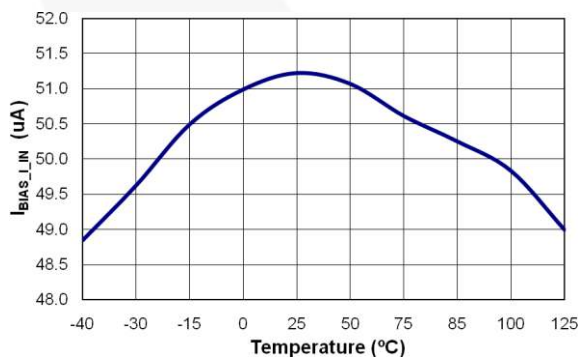

Figure 10. I_{IN} Bias Current ($I_{BIAS_I_IN}$) vs. Temperature

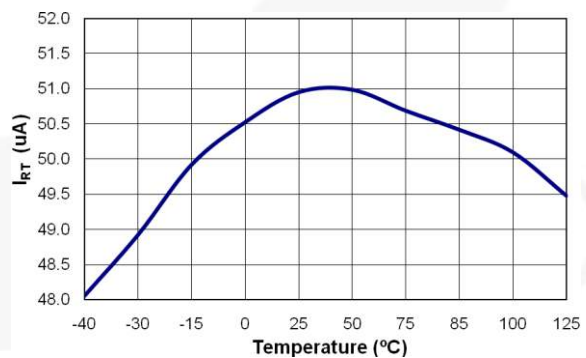

Figure 11. RT Current Source (I_{RT}) vs. Temperature

Typical Performance Characteristics (Continued)

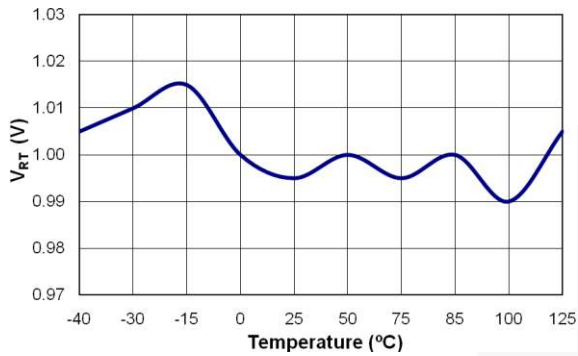

Figure 12. OTP Threshold Voltage (V_{RT}) vs. Temperature

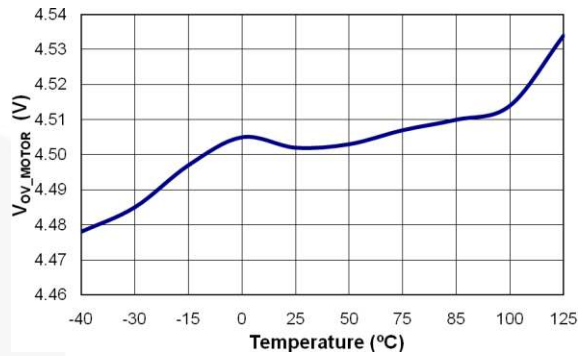

Figure 13. Motor OVP Threshold Voltage (V_{OV_MOTOR}) vs. Temperature

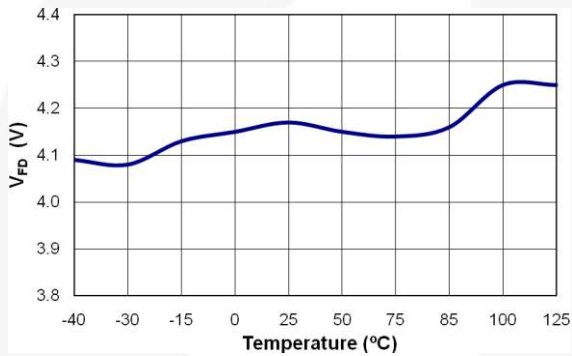

Figure 14. PWM Full Duty Voltage (V_{FD}) vs. Temperature

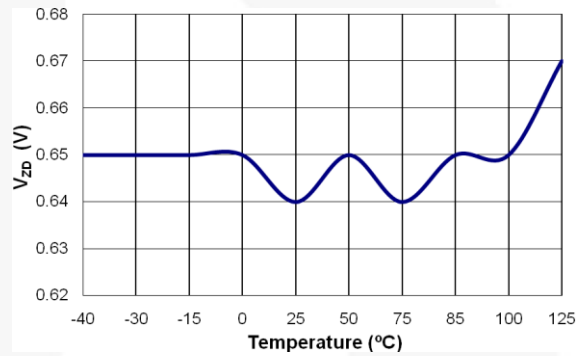

Figure 15. PWM Zero Duty Voltage (V_{ZD}) vs. Temperature

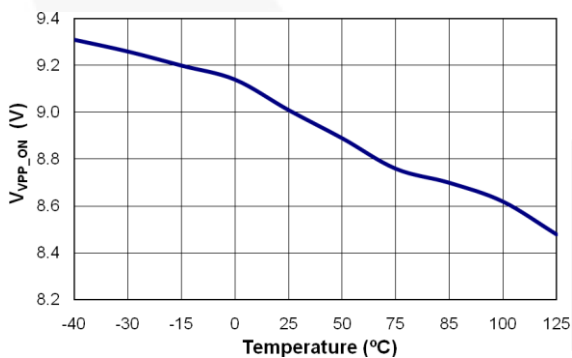

Figure 16. V_{PP} Turn-On Threshold Voltage (V_{VPP_ON}) vs. Temperature

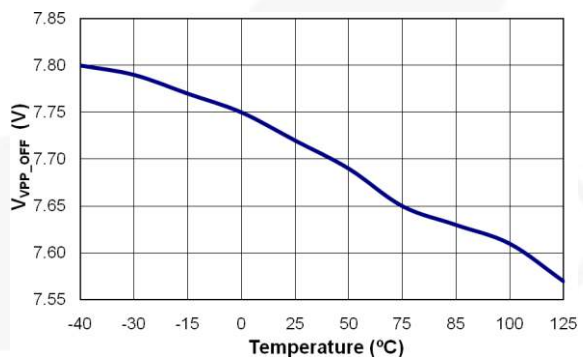

Figure 17. V_{PP} Turn-Off Threshold Voltage (V_{VPP_OFF}) vs. Temperature

Functional Description

Power Management and Regulator

FCM8201 can be operated in a wide input voltage (V_{PP}) range from 10 V to 15 V. The VOUT pin is the output terminal of an internal voltage regulator. The typical output voltage ranges is between 5.0 V and 5.2 V. To stabilize the V_{OUT} circuit, add an external capacitor connected closely between this terminal and the ground. If the V_{PP} voltage is lower than the 8 V threshold, FCM8201 shuts down and all the internal registers are reset.

Clock Generator

FCM8201 comes with a programmable oscillator. By determining an externally added resistor R_{CLK} , the system clock can be programmed from 960 kHz to 1920 kHz. The switching frequency of the PWM signal is equal to $1/64$ (divided by $\div 64$) of the system clock. Therefore, when the system clock is configured as 960 kHz, PWM is $960 \text{ kHz} / 64 = 15 \text{ kHz}$. Similarly, if a 20 kHz PWM is intended, the system clock has to be set as 1.28 MHz.

PWM Commutation

FCM8201 supports both square-wave and sine-wave PWM for the BLDC motor control. The controller comes with the hall-sensor design used to align the rotor position of the motor. For the Square-Wave PWM Mode, the PWM output commutation (PWM-PWM and PWM-ON) is shown at Table 1 and Table 2. The Square-Wave PWM Modes can be selected by setting an internal control register through the SPI interface. The default value of PWM-PWM commutation is shown in Table 1.

Table 1. Square Wave PWM-PWM Commutation

CW	Hall	Hall	U-V-W	X-Y-Z
X	000	0	0-0-0	0-0-0
X	111	7	0-0-0	0-0-0
1	001	1	P-0-0	Pb-1-0
1	011	3	0-0-P	0-1-Pb
1	010	2	0-0-P	1-0-Pb
1	110	6	0-P-0	1-Pb-0
1	100	4	0-P-0	0-Pb-1
1	101	5	P-0-0	Pb-0-1
0	101	5	0-0-P	1-0-Pb
0	100	4	0-0-P	0-1-Pb
0	110	6	P-0-0	Pb-1-0
0	010	2	P-0-0	Pb-0-1
0	011	3	0-P-0	0-Pb-1
0	001	1	0-P-0	1-Pb-0

Table 2. Square Wave PWM-ON Commutation

CW	Hall	Hall	U-V-W	X-Y-Z
X	000	0	0-0-0	0-0-0
x	111	7	0-0-0	0-0-0
1	001	1	1-Pb-0	0-P-0
1	011	3	0-0-P	0-1-Pb
1	010	2	Pb-0-1	P-0-0
1	110	6	0-P-0	1-Pb-0
1	100	4	0-1-Pb	0-0-P
1	101	5	P-0-0	Pb-0-1
0	101	5	0-0-P	1-0-Pb
0	100	4	0-Pb-1	0-P-0
0	110	6	P-0-0	Pb-1-0
0	010	2	1-0-Pb	0-0-P
0	011	3	0-P-0	0-Pb-1
0	001	1	Pb-1-0	P-0-0

Note:

1. P = PWM, Pb = PWM inverse.

HALL Signals Input

FCM8201 provides a 3~6 μs debounce time for each Hall signal input to reduce the glitch of the Hall signals. When the transition of the Hall signal is slow, a glitch might be produced and an error follow. Through a built-in Hall signal regulation circuit, FCM8201 minimizes the risks of glitches and related errors. This function can be enabled or disabled through a control register via the SPI interface.

The Hall signal's polarity can be configured by setting the levels of HA_INV, HB_INV, and HC_INV. For example, if HA_INV = 1, an internal Hall-a signal is the inverse of the HA pin. Otherwise, the internal Hall-a signal is the same as the signal on the HA pin.

PWM Duty Cycle and Operation

The PWM duty is proportional to the voltage levels on the OPO pin and DUTY pin. A FREE/nST pin is utilized to enable the PWM signals. When FREE/nST pin is set as logic HIGH, the PWM state is in free mode and all PWM outputs (U, V, W, X, Y, Z pins) are logic LOW. Once the FREE/nST pin goes logic LOW, the FCM8201 starts operating the PWM. FCM8201 supports various PWM operation modes to fit different application needs. The detailed description is shown in the Table 6 SPI Register Table.

Sine Wave Generator

FCM8201 includes space vector modulation (SVM) for the sine-wave PWM. An angle-detect circuit phase-locks the rotor position by using the Hall signals of the motor. The resolution is 32 steps per 60 degrees. Through the PWM operation, the motor current of each phase is sine-wave. The angle shift between phases is 120°.

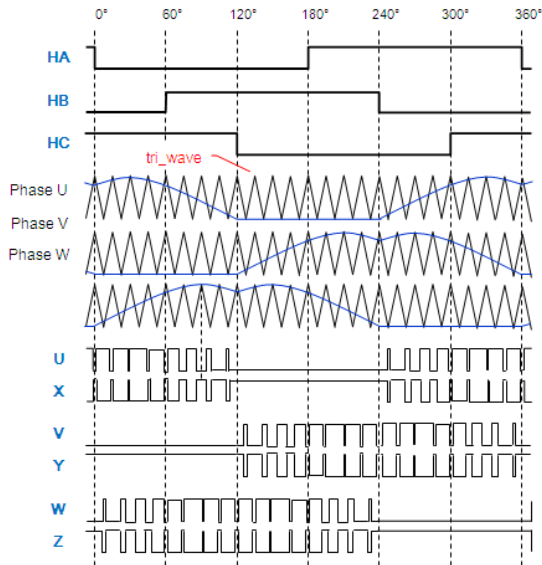

Figure 18. Sine Wave Output at CW = 1

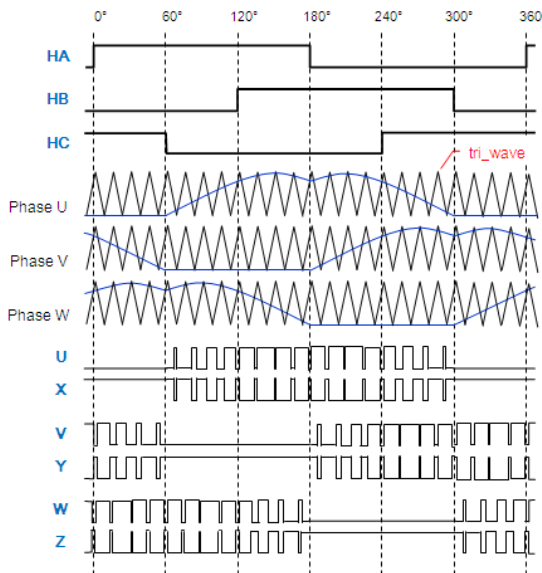

Figure 19. Sine Wave Output at CW = 0

Current Feedback and Protections

The current feedback circuit provides two major functions: generating a current feedback signal for the motor control and supporting over-current protections. The I_IN pin outputs 50 μA current to provide a DC bias on the I_IN terminal to prevent a negative voltage, shown in Equation (1) for the I_FB and the I_IN. A 0.5 V DC bias on I_IN is recommended. The maximum average current signal is 1 V. Using these parameters, the maximum I_FB signal swing is 0.5 V ~ 4.5 V.

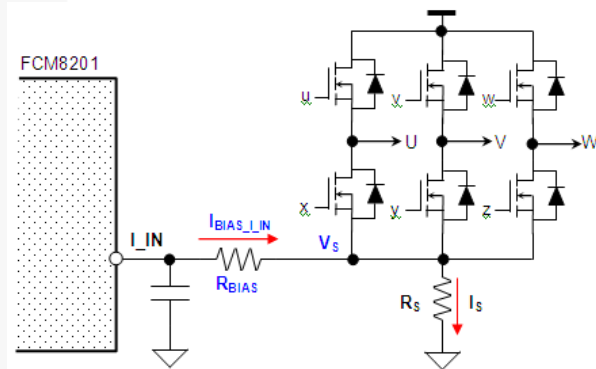

Figure 20. Current Feedback Flow

$$V_{I_FB} = (V_S \times 8) + (I_{BIAS_I_IN} \times R_{BIAS}) \quad (1)$$

FCM8201 provides three different levels of over-current (OC) protections. The first level is 1.4 V, used for over-load current protection with OC timer delay. If the I_IN is higher than 1.4 V, the OC timer is triggered. The OC_Latch is enabled once the timer exceeds its time-out limit. The second level is 1.5 V, used for the cycle-by-cycle current limit. The PWM signal is turned off immediately when the I_IN is > 1.5 V. The third level is 2.5 V, designed for the short-circuit protection. If the I_IN is > 2.5 V for over three PWM pulses, all PWM outputs (U, V, W, X, Y, Z pins) are turned off.

Protections and Faults

Table 3. Faults Table

Type	State	Trigger	Release
V _{PP} OV	Free	V _{PP} > 18 V	
V _{PP} UV	Free, Reset	V _{PP} < 8 V	
V _{OUT} UV	Free	V _{OUT} < 4 V	
R _T	Free	R _T < 1.0 V	R _T > 1.2 V
OS	Free	Open & Short	↑Run
Hall Error	Free	Hall = 000 or 111	
HOVP	Free	V _{SENSE} > 4.5 V	
OC_Latch	Free	I_IN > 1.4 V	↑Run
Watch Dog	Free	WDT Time Out	Register
SHORT	Free	I_IN > 2.5 V	↑Run

Digital-to-Analog Converter

FCM8201 has an 8-bit digital-to-analog converter (DAC) to control the DUTY and IP through the SPI interface.

Analog to Digital Converter

FCM8201 has a 5-bit analog-to-digital converter (ADC) for the signal on AS, VSENSE, I_FB, and RT pins. Its voltage can be read through the SPI interface.

I/O Optional Function

The pins 5~8 of FCM8201 are two types of I/O for both stand-alone and microcontroller (SPI mode) applications. FCM8201 uses stand-alone mode by default. The microcontroller should use pin 7 (XP) and pin 8 (XN) to complete the signal toggle procedure

shown in Figure 21. In the way, FCM8201 activates SPI operation mode. Afterwards, The pins 5~8 change to SPI function.

To return from SPI mode to stand-alone mode, the microcontroller has to complete the signal toggle procedure shown in Figure 22.

SPI Interface

The microcontroller can access FCM8201 through the SPI interface. In SPI operation mode, FCM8201 provides more motor control function than in stand-alone operation mode. *Please refer to the Table 6 and Table 7 for the details.*

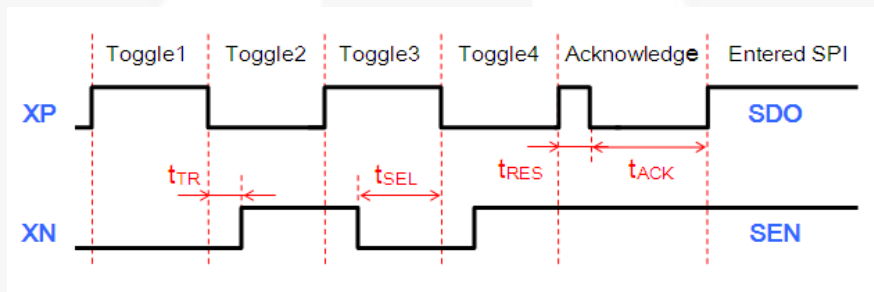

Figure 21. I/O Select Timing of Entering SPI Mode

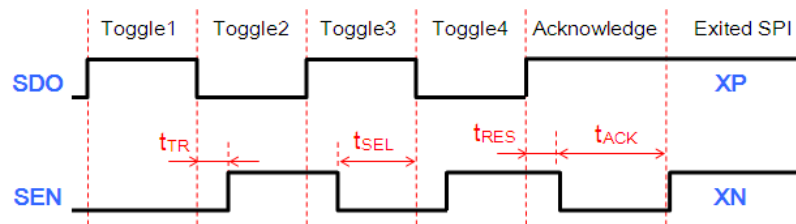

Figure 22. I/O Select Timing of Exiting SPI Mode

Table 4. Timing Specification of I/O Function Selection

Symbol	Parameter	Conditions	Min.	Typ.	Max.	Unit
t_{SEL}	Select-Bit Stable Time	$f_{SYS} = 1.28 \text{ MHz}$	12		100	μs
t_{TR}	Select-Bit Transient Time	$f_{SYS} = 1.28 \text{ MHz}$	0		12	μs
t_{ACT}	Acknowledge Bit Pull LOW Time	$f_{SYS} = 1.28 \text{ MHz}$		1		ms
t_{RES}	FCM8201 Response Time	$f_{SYS} = 1.28 \text{ MHz}$		4		μs

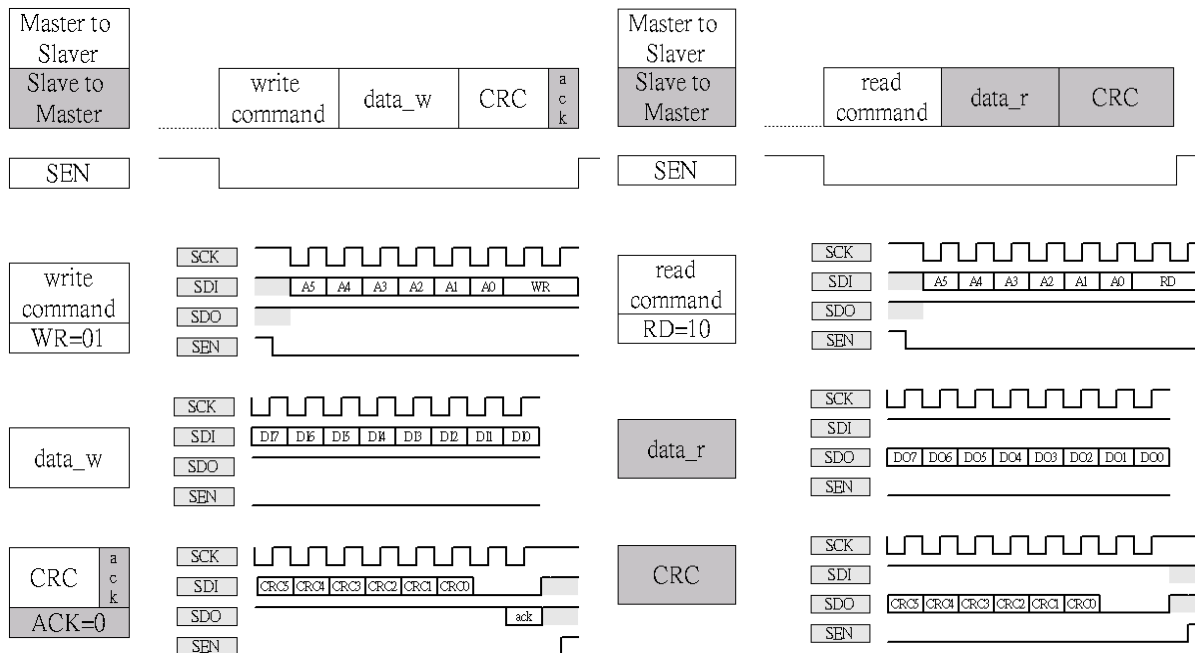

Figure 23. SPI Bit Definition

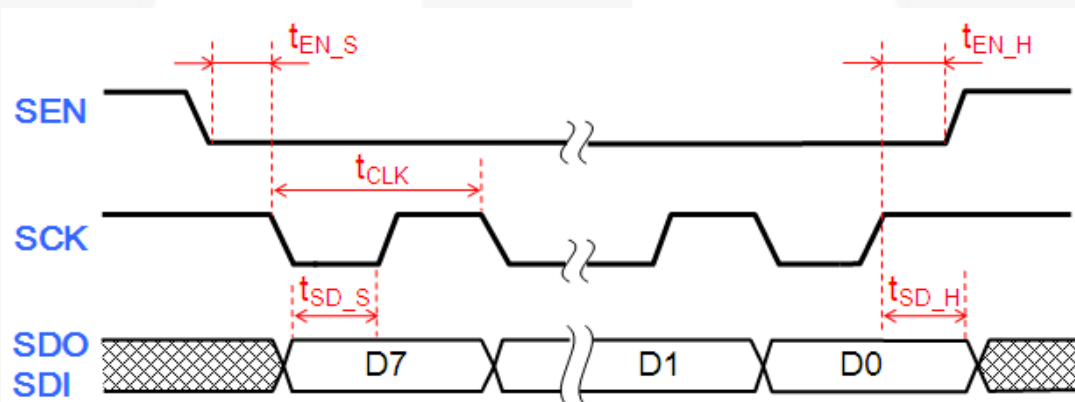

Figure 24. SPI Timing Specification

Table 5. Timing Specification of SPI

Symbol	Parameter	Conditions	Min.	Typ.	Max.	Unit
t_{EN_S}	Setup Time of SEN	$f_{SYS} = 1.28 \text{ MHz}$		2		μs
t_{EN_H}	Hold Time of SEN	$f_{SYS} = 1.28 \text{ MHz}$		2		μs
t_{SD_S}	Setup Time of SDO/SDI	$f_{SYS} = 1.28 \text{ MHz}$		0		μs
t_{SD_H}	Hold Time of SDO/SDI	$f_{SYS} = 1.28 \text{ MHz}$		2		μs
t_{CLK}	Maximum Clock Rate of SPI	$f_{SYS} = 1.28 \text{ MHz}$	12.5			μs
t_{TMR_OUT}	SCK Time-Out	$f_{SYS} = 1.28 \text{ MHz}$	90	100		ms

Table 6. SPI Register Table (Read/Write)

CNTL_REG: System Control Register										
Addr.	Name	Type	B7	B6	B5	B4	B3	B2	B1	B0
0x00	CNTL	W/R	TMR_CLR	OC_TMR2	OC_TMR1	OC_TMR0	IP_EA	DT_EA	CW	FREE/nST
		Reset	0	0	0	0	0	0	1	1
		b7	TMR_CLR	OC Timer Clear 1 = OC timer clear, 0 = OC time is normal function						
		b[6:4]	OC_TMR[2:0]	Overload Current Protection Timer Configuration 000 = OC timer configure by OC_TMR pin 001 = OC timer configure to $2^{18} \div f_{SYS}$ 010 = OC timer configure to $2^{19} \div f_{SYS}$ 011 = OC timer configure to $2^{20} \div f_{SYS}$ 100 = OC timer configure to $2^{21} \div f_{SYS}$ 101 = OC timer configure to $2^{22} \div f_{SYS}$ 110 = OC timer configure to $2^{23} \div f_{SYS}$ 111 = OC timer configure to $2^{24} \div f_{SYS}$						
		b3	IP_EA	IP_REG Enable 1 = duty control by IP_REG, 0 = duty control by IP pin						
		b2	DT_EA	DUTY_REG Enable 1 = duty control by DUTY_REG, 0 = duty control by DUTY pin						
		b1	CW	Output Driving Current Direction 1 = CW, 0 = CCW						
		b0	FREE/nST	FREE or START 1 = FREE (PWM outputs disable), 0 = START (PWM outputs enable)						
PWM_REG: PWM Control Register										
Addr.	Name	Type	B7	B6	B5	B4	B3	B2	B1	B0
0x01	PWM	W/R	PMOD	n/a	DT1	DT0	SEQ_TBL	SYNCOFF	EXT_SYN	LPWM
		Reset	0	0	0	0	0	0	0	0
		b7	PMOD	PWM Mode Select 0 = sine wave PWM drive after angle detector locked 1 = square wave PWM drive after angle detector locked						
		b[5:4]	DT[1:0]	Soft Switching Dead Time Setting 00 = 2.5 μ s, 01 = 2.0 μ s, 10 = 4.0 μ s, 11 = 3.5 μ s						
		b3	SEQ_TBL	Square Wave Sequencer Table Select 0 = "PWM-PWM" commutation, 1 = "PWM-ON" commutation						
		b2	SYNCOFF	Synchronous Rectifier (SR) Disable 0 = SR Enable, 1 = SR Disable						
		b1	EXT_SYN	External Synchronous Rectifier Configure 0 = SR function control by SYNCOFF bit 1 = SR function control by OC_TMR pin In this selection, the OC_TMR[2:0] bits of CNTL_REG can't be set to 0, too OC_TMR pin: HIGH = SR enable, LOW = SR disable						
		b0	LPWM	Low-Side Minimum PWM Output Enable. This function is working only on square wave PWM driving 0 = Low side minimum PWM duty output disable 1 = Low side minimum PWM duty output enable						

Continued on the following page...

ANG_REG: Angle Shift Control Register										
Addr.	Name	Type	B7	B6	B5	B4	B3	B2	B1	B0
0x02	ANG	W/R	ANG_SEL	ARNG1	ARNG0	ANG4	ANG3	ANG2	ANG1	ANG0
		Reset	0	0	0	0	0	0	0	0
	b7	ANG_SEL	Angle Shift Control Input Select 0 = Set by AS pin, 1 = Set by ANG[4:0]							
	b[6:5]	ARNG[1:0]	Angle Predictor Working Range Select 00 = Work in 0.8 ~ 80 Hz Hall frequency, 48 ~ 4800 rpm at 2-pole motor 01 = Work in 0.4 ~ 40 Hz Hall frequency, 24 ~ 2400 rpm at 2-pole motor 1x = Work in 3.2 ~ 320 Hz Hall frequency, 192 ~ 19200 rpm at 2-pole motor							
	b[4:0]	ANG[4:0]	Angle Setting of Angle Shift Function 0~31 = 0 ~ 60 degrees							
SVM_REG: Sine Wave Generator Control Register										
Addr.	Name	Type	B7	B6	B5	B4	B3	B2	B1	B0
0x03	SVM	W/R	SIN_MAU	SIN_EA	n/a	n/a	n/a	n/a	n/a	n/a
		Reset	0	0	0	0	0	0	0	0
	b7	SIN_MAU	Sine Wave Driving Force Active 0 = Sine wave automatic active 1 = Sine wave active by SIN_EA bit and ignore AS < 0.2 V							
	b6	SIN_EA	Sine Wave Enable (This function only active on while SIN_MAU = 1) 0 = Sine wave disable, 1 = Sine wave enable							
HALL_REG: Hall Signals Control Register										
Addr.	Name	Type	B7	B6	B5	B4	B3	B2	B1	B0
0x04	HALL	W/R	n/a	n/a	n/a	n/a	HREG	HC_INV	HB_INV	HA_INV
		Reset	0	0	0	0	0	0	0	0
	b3	HREG	Hall Signals Regulation Enable 0 = disable, 1 = enable							
	b2	HC_INV	Hall C Input Invert 0 = non-invert, 1 = invert							
	b1	HB_INV	Hall B Input Invert 0 = non-invert, 1 = invert							
	b0	HA_INV	Hall A Input Invert 0 = non-invert, 1 = invert							

Continued on the following page...

WDT_REG: Watch Dog Timer Control Register

Addr.	Name	Type	B7	B6	B5	B4	B3	B2	B1	B0
0x06	WDT	W/R	OSL_DIS	OTL_DIS	n/a	CRC_ON	WDT_EN	CLR	W_TMR1	W_TMR0
		Reset	0	0	0	0	0	0	0	0
		b7	OSL_DIS	Open Short (OS) Fault Latch Disable 0 = OS protect does not latch 1 = OS protect does latch and clear by FREE/nST pin rising edge or FREE/nST bit = 1						
		b6	OTL_DIS	Over Temperature Fault Latch Disable 0 = OTP protect does not latch 1 = OTP protect will latch, and clear by FREE/nST pin rising edge or FREE/nST bit = 1						
		b4	CRC_ON	SPI CRC Check Enable 0 = SPI CRC check disable 1 = SPI CRC check enable						
		b3	WDT_EN	Watch Dog Timer Enable 0 = watch dog timer disable 1 = watch dog timer enable and outputs a faulty when the counter reaches time-out						
		b2	CLR	Watch Dog Timer Clear (This bit is effective only when WDT_EN=1) 1 = WDT counter reset, after counter is cleared to zero, this bit auto-resets to 0						
		b[1:0]	W_TMR[1:0]	Watch Dog Timer Counter Select 00 = 0.25 s at $f_{SYS}=1.28$ MHz 01 = 0.5 s at $f_{SYS}=1.28$ MHz 10 = 1 s at $f_{SYS}=1.28$ MHz 11 = 2 s at $f_{SYS}=1.28$ MHz						

DUTY_REG: Duty Control Register

Addr.	Name	Type	B7	B6	B5	B4	B3	B2	B1	B0
0x08	DUTY	W/R	DUTY7	DUTY6	DUTY5	DUTY4	DUTY3	DUTY2	DUTY1	DUTY0
		Reset	0	0	0	0	0	0	0	0
		b[7:0]	DUTY[7:0]	DUTY Level Configure 0 ~ 255 = 0.5 ~ 4.5 V						

IP_REG: Error Amplifier IP Pin Control Register

Addr.	Name	Type	B7	B6	B5	B4	B3	B2	B1	B0
0x09	IP	W/R	IP7	IP6	IP5	IP4	IP3	IP2	IP1	IP0
		Reset	0	0	0	0	0	0	0	0
		b[7:0]	IP[7:0]	IP Pin Level of Error Amplifier Configure 0 ~ 255 = 0.5 ~ 4.5 V						

Table 7. SPI Registers Table (Read Only)

AS_REG: AS Pin Voltage Level Read Register										
Addr.	Name	Type	B7	B6	B5	B4	B3	B2	B1	B0
0x20	AS	R	n/a	n/a	n/a	AS4	AS3	AS2	AS1	AS0
b[4:0]		AS[4:0]	AS voltage = (AS[4:0] × 0.125) + 0.5 V							
VSENSE_REG: VSENSE Pin Voltage Level Read Register										
Addr.	Name	Type	B7	B6	B5	B4	B3	B2	B1	B0
0x21	VSENSE	R	n/a	n/a	n/a	VS4	VS3	VS2	VS1	VS0
b[4:0]		VS[4:0]	VSENSE voltage = (VS[4:0] × 0.125) + 0.5 V							
I_FB_REG: I_FB Pin Voltage Level Read Register										
Addr.	Name	Type	B7	B6	B5	B4	B3	B2	B1	B0
0x22	I_FB	R	n/a	n/a	n/a	IFB4	IFB3	IFB2	IFB1	IFB0
b[4:0]		IFB[4:0]	I_FB voltage = (IFB[4:0] × 0.125) + 0.5 V							
RT_REG: RT Pin Voltage Level Read Register										
Addr.	Name	Type	B7	B6	B5	B4	B3	B2	B1	B0
0x23	RT	R	n/a	n/a	n/a	RT4	RT3	RT2	RT1	RT0
b[4:0]		RT[4:0]	RT voltage = (RT[4:0] × 0.125) + 0.5 V							
HPERH_REG: Hall Period Counter HIGH Byte										
Addr.	Name	Type	B7	B6	B5	B4	B3	B2	B1	B0
0x26	HPERH	R	HP15	HP14	HP13	HP12	HP11	HP10	HP9	HP8
b[7:0]		HP[15:8]	Hall period count HIGH byte, bit [15:8]							
HPERL_REG: Hall Period Counter LOW Byte										
Addr.	Name	Type	B7	B6	B5	B4	B3	B2	B1	B0
0x27	HPERL	R	HP7	HP6	HP5	HP4	HP3	HP2	HP1	HP0
b[7:0]		HP[7:0]	Hall period count LOW byte, bit [7:0]							
STATUS_REG: System Status Register										
Addr.	Name	Type	B7	B6	B5	B4	B3	B2	B1	B0
0x28	STATUS	R	OT	OC	OS	OV	H_ERR	DIR	WDT	SHORT
b7		OT	1 = Over-temperature protection triggered (RT pin voltage < V _{RT})							
b6		OC	1 = Overload current protection triggered							
b5		OS	1 = Open/Short protection triggered							
b4		OV	1 = Motor drive over-voltage protection triggered (VSENSE pin voltage > V _{OV_MOTOR})							
b3		H_ERR	1 = Hall signals error (HA/B/C=1/1/1 or 0/0/0)							
b2		DIR	1 = Hall direction different from that on the PWM sequencer table							
b1		WDT	1 = Watch dog time-out triggered							
b0		SHORT	1 = Short-circuit current protection triggered							

Physical Dimensions

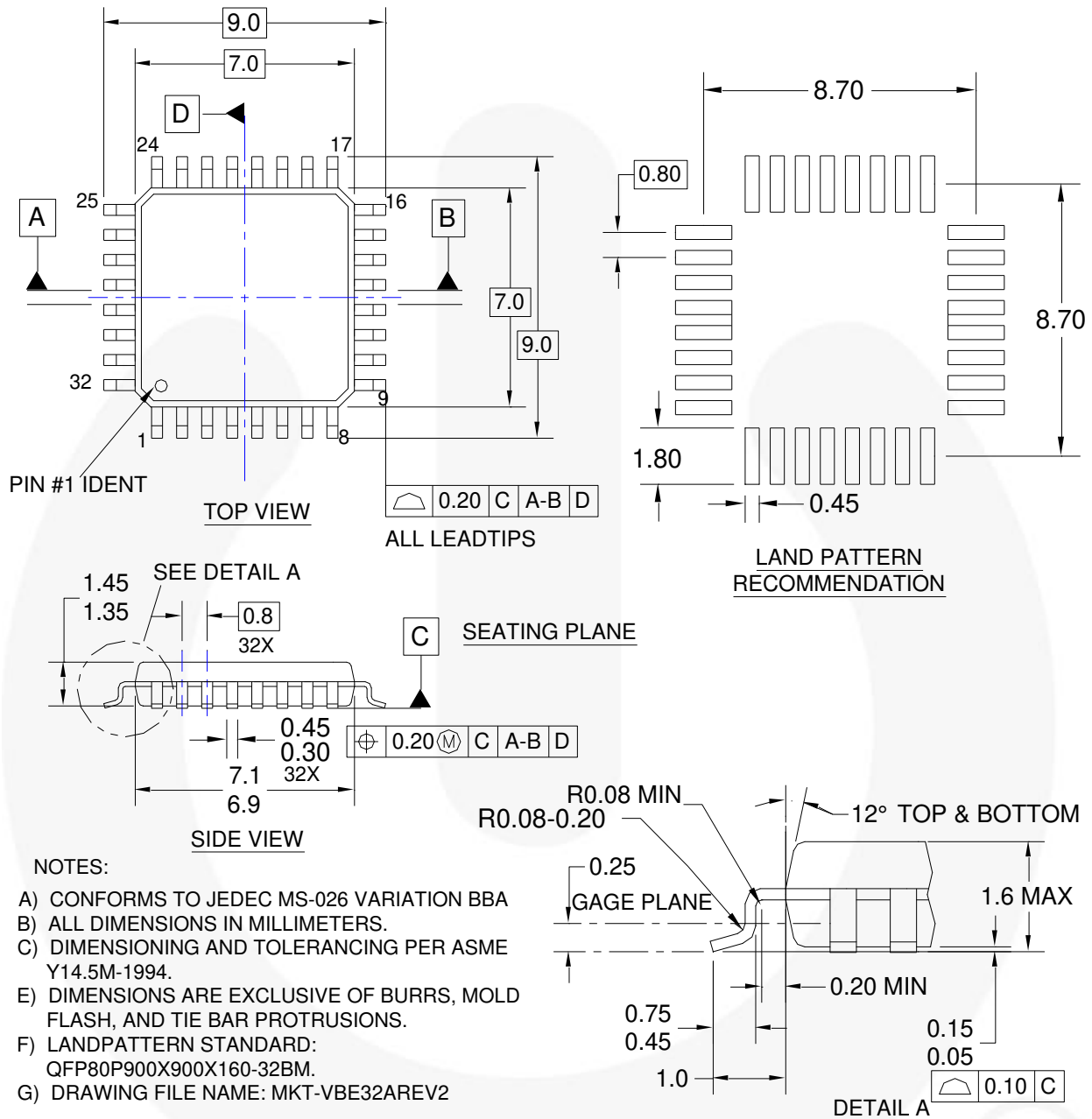

Figure 25. 32-Lead, Low-Profile, Quad Flat Pack Package (LQFP)

Package drawings are provided as a service to customers considering Fairchild components. Drawings may change in any manner without notice. Please note the revision and/or date on the drawing and contact a Fairchild Semiconductor representative to verify or obtain the most recent revision. Package specifications do not expand the terms of Fairchild's worldwide terms and conditions, specifically the warranty therein, which covers Fairchild products.





Always visit Fairchild Semiconductor's online packaging area for the most recent package drawings:

<http://www.fairchildsemi.com/dwg/VB/VBE32A.pdf>



TRADEMARKS

The following includes registered and unregistered trademarks and service marks, owned by Fairchild Semiconductor and/or its global subsidiaries, and is not intended to be an exhaustive list of all such trademarks.

- | | | | |
|---|--|---|---|
| AccuPower™ | F-PFS™ |  | Sync-Lock™ |
| AX-CAP®* | FRFET® | PowerXS™ |  |
| BitSiC™ | Global Power Resource™ | Programmable Active Droop™ | TinyBoost® |
| Build it Now™ | GreenBridge™ | QFET® | TinyBuck® |
| CorePLUS™ | Green FPS™ | QS™ | TinyCalc™ |
| CorePOWER™ | Green FPS™ e-Series™ | Quiet Series™ | TinyLogic® |
| CROSSVOLT™ | Gmax™ | RapidConfigure™ | TINYOPTO™ |
| CTL™ | GTO™ |  | TinyPower™ |
| Current Transfer Logic™ | IntelliMAX™ | Saving our world, 1mW/W/kW at a time™ | TinyPWM™ |
| DEUXPEED® | ISOPLANAR™ | SignalWise™ | TinyWire™ |
| Dual Cool™ | Making Small Speakers Sound Louder and Better™ | SmartMax™ | TranSiC™ |
| EcoSPARK® | MegaBuck™ | SMART START™ | TriFault Detect™ |
| EfficientMax™ | MICROCOUPLER™ | Solutions for Your Success™ | TRUECURRENT®* |
| ESBC™ | MicroFET™ | SPM® | µSerDes™ |
|  | MicroPak™ | STEALTH™ |  |
| Fairchild® | MicroPak2™ | SuperFET® | UHC® |
| Fairchild Semiconductor® | MillerDrive™ | SuperSOT™-3 | Ultra FRFET™ |
| FACT Quiet Series™ | MotionMax™ | SuperSOT™-6 | UniFET™ |
| FACT® | mWSaver® | SuperSOT™-8 | VCX™ |
| FAST® | OptoHiT™ | SupreMOS® | VisualMax™ |
| FastvCore™ | OPTOLOGIC® | SyncFET™ | VoltagePlus™ |
| FETBench™ | OPTOPLANAR® | | XS™ |
| FPS™ | | | |

* Trademarks of System General Corporation, used under license by Fairchild Semiconductor.

DISCLAIMER

FAIRCHILD SEMICONDUCTOR RESERVES THE RIGHT TO MAKE CHANGES WITHOUT FURTHER NOTICE TO ANY PRODUCTS HEREIN TO IMPROVE RELIABILITY, FUNCTION, OR DESIGN. FAIRCHILD DOES NOT ASSUME ANY LIABILITY ARISING OUT OF THE APPLICATION OR USE OF ANY PRODUCT OR CIRCUIT DESCRIBED HEREIN; NEITHER DOES IT CONVEY ANY LICENSE UNDER ITS PATENT RIGHTS, NOR THE RIGHTS OF OTHERS. THESE SPECIFICATIONS DO NOT EXPAND THE TERMS OF FAIRCHILD'S WORLDWIDE TERMS AND CONDITIONS, SPECIFICALLY THE WARRANTY THEREIN, WHICH COVERS THESE PRODUCTS.

LIFE SUPPORT POLICY

FAIRCHILD'S PRODUCTS ARE NOT AUTHORIZED FOR USE AS CRITICAL COMPONENTS IN LIFE SUPPORT DEVICES OR SYSTEMS WITHOUT THE EXPRESS WRITTEN APPROVAL OF FAIRCHILD SEMICONDUCTOR CORPORATION.

As used herein:

1. Life support devices or systems are devices or systems which, (a) are intended for surgical implant into the body or (b) support or sustain life, and (c) whose failure to perform when properly used in accordance with instructions for use provided in the labeling, can be reasonably expected to result in a significant injury of the user.
2. A critical component in any component of a life support, device, or system whose failure to perform can be reasonably expected to cause the failure of the life support device or system, or to affect its safety or effectiveness.

ANTI-COUNTERFEITING POLICY

Fairchild Semiconductor Corporation's Anti-Counterfeiting Policy. Fairchild's Anti-Counterfeiting Policy is also stated on our external website, www.fairchildsemi.com, under Sales Support.

Counterfeiting of semiconductor parts is a growing problem in the industry. All manufacturers of semiconductor products are experiencing counterfeiting of their parts. Customers who inadvertently purchase counterfeit parts experience many problems such as loss of brand reputation, substandard performance, failed applications, and increased cost of production and manufacturing delays. Fairchild is taking strong measures to protect ourselves and our customers from the proliferation of counterfeit parts. Fairchild strongly encourages customers to purchase Fairchild parts either directly from Fairchild or from Authorized Fairchild Distributors who are listed by country on our web page cited above. Products customers buy either from Fairchild directly or from Authorized Fairchild Distributors are genuine parts, have full traceability, meet Fairchild's quality standards for handling and storage and provide access to Fairchild's full range of up-to-date technical and product information. Fairchild and our Authorized Distributors will stand behind all warranties and will appropriately address any warranty issues that may arise. Fairchild will not provide any warranty coverage or other assistance for parts bought from Unauthorized Sources. Fairchild is committed to combat this global problem and encourage our customers to do their part in stopping this practice by buying direct or from authorized distributors.

PRODUCT STATUS DEFINITIONS

Definition of Terms

Datasheet Identification	Product Status	Definition
Advance Information	Formative / In Design	Datasheet contains the design specifications for product development. Specifications may change in any manner without notice.
Preliminary	First Production	Datasheet contains preliminary data; supplementary data will be published at a later date. Fairchild Semiconductor reserves the right to make changes at any time without notice to improve design.
No Identification Needed	Full Production	Datasheet contains final specifications. Fairchild Semiconductor reserves the right to make changes at any time without notice to improve the design.
Obsolete	Not In Production	Datasheet contains specifications on a product that is discontinued by Fairchild Semiconductor. The datasheet is for reference information only.

Rev. I66