

RECOMMENDED P.C.B. LAYOUT

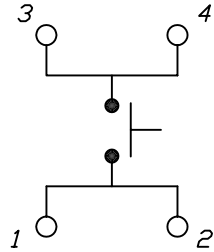

CIRCUIT: SPST  
CONTACT CONFIGURATION

NOTES:

1. ALL DIMENSIONS IN MM [INCH]
2. GENERAL TOLERANCE: X.X=±0.4  
X.XX=±0.25
3. TERM. NOS. FOR REF. ONLY
4. RATING: 50mA, @12V DC
5. TRAVEL: 0.25 +0.2/-0.1mm
6. CONTACT RESISTANCE: 20 MILLIOHMS INITIAL.
7. ELECTRICAL LIFE: 100,000 CYCLES
- ▲ 8. PACKAGING: TAPE AND REEL.
9. ▲ DENOTES CRITICAL PARAMETER.

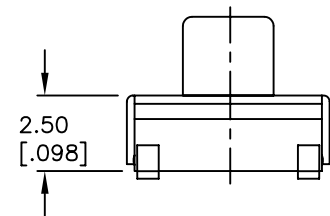
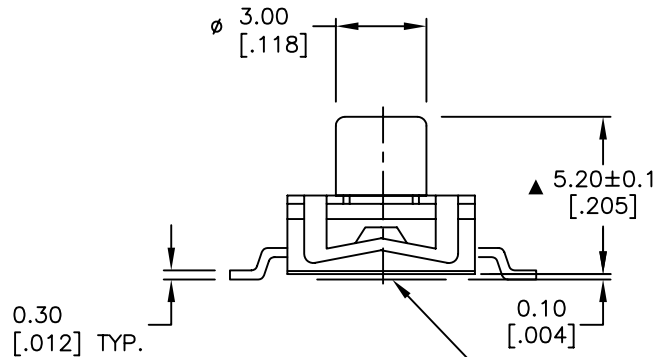
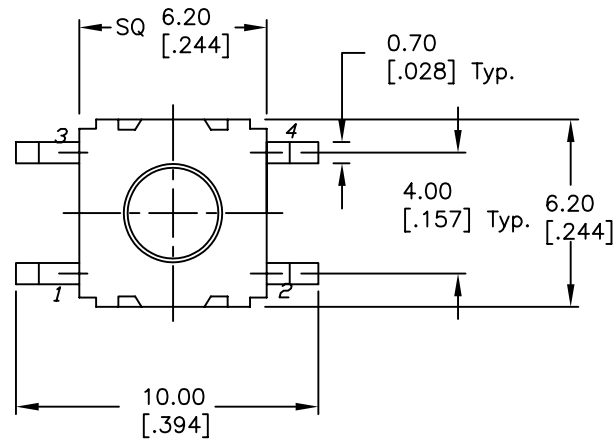

ALL TERMINALS MUST BE CO-PLANAR  
w/in 0.10 [.004] TOTAL.

F	14917	REMOVE EPOXY ON TERMINALS	5/20/05	BK
E	14843	REMOVE NOTE 9	4/8/05	AR
D	14482	ADD EPOXY NOTE AND NOTE 9	11/10/04	AR
C	13959	CHANGE DESCRIPTION	4/27/04	AR
B	13623	DIM 0.30 WAS 0.25	11/25/03	AR
A	12603	RELEASED	12/2/02	CB
REV.	ECN No.	DESCRIPTION	DATE	CHKD

THE INFORMATION CONTAINED IN THIS DOCUMENT  
IS PROPRIETARY TO E-SWITCH AND IS  
NOT TO BE COPIED OR TRANSFERRED

**E-SWITCH®**

TITLE

TL6304BF160QG

SCALE

4:1

DATE

12/02/02

DR

CB

DWG

D310738

REV

F