

Quartz Crystal

Product Catalogue





Contents

Quartz Crystal Products	6		
Ceramic package		Cylinder	
SC-12S	7	VT-200-F	19
SC-16S	8	VT-200-FL(Cylinder type low CL resonator for low-power microcontrollers)	20
SC-20S	9		
SC-20P	10	Oscillator	
SC-20T	11	Crystal Oscillator 32.768kHz SN-20S	21
SC-20A (For automotive use)	12	High accuracy Crystal Oscillator 32.768kHz SH-32R ...	22
SC-32S	13		
SC-32A (For automotive use)	14	Check sheet for crystal products selection	23
SC-32P (R1=50k Ω max.) Low ESR Series	15	Environmental Activites	24
SC-32L (R1=40k Ω max.) Low ESR Series	16	Quartz Crystal Unit Handling Precautions	25
		Oscillation Circuit Design Precautions	28
Plastic mold		Packing	30
SSP-T7-F	17		
SSP-T7-FL (SMD type low CL resonator for low-power microcontrollers)	18		

Creating Time - Optimizing Time - Enriching Time

Seiko Instruments Inc. (SII), founded in 1937 as a member of the Seiko Group specializing in the manufacture of watches, has leveraged its core competency in high precision watches to create a wide range of new products and technologies.

Over the years SII has developed high-precision processed parts and machine tools that pride themselves on their sub-micron processing capability, quartz crystals that came about as a result of our quartz watch R&D, and electronic components such as micro batteries.

Optimizing our extensive experience and expertise, we have since diversified into such new fields as compact, lightweight, exceedingly quiet thermal printers, and inkjet printheads, a key component in wide format inkjet printers for corporate use.

SII, in the years to come, will maintain an uncompromised dedication to its time-honored technologies and innovations of craftsmanship, miniaturization, and efficiency that meet the needs of our changing society and enrich the lives of those around us.

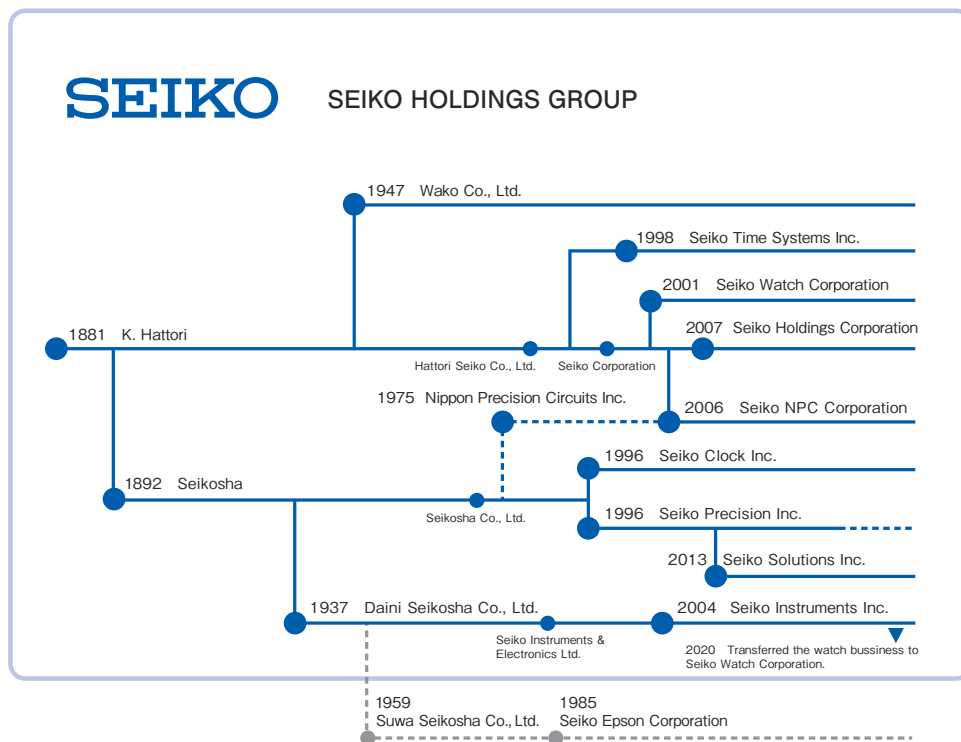

PRECISION, CRAFTSMANSHIP and MINIATURIZATION

Leveraging Watch Making Technology

🕒 With Precision, we apply our Craftsmanship to provide Miniaturization advantages to customers' product development around the world.

Stable and reliable
Rechargeable Battery & Capacitor

For the IoT product

No corrosion, strong, ultra high elasticity and no magnetization
Superior material
"SPRON"

For material used in harsh environments

For magnetic applied sensor components

For wearable devices

Excellent heat and corrosion resistance
Samarium-cobalt Magnet
"DIANET"

Precise Timing with
Lowest Power consumption

Small and powerful
Silver Oxide Battery
Silver Oxide Battery
"SEIZAIKEN"

Precise Timing for Electronic Devices

Tuning Fork Quartz Crystal Resonator

Electronic Components and High-performance Materials

SII's electronic components were originally derived from the development and manufacturing of quartz watches.



Since 1953

**No corrosion, strong,
ultra high elasticity
Co-Ni alloy product**

"SPRON"

The sophisticated metal product, "SPRON", was born as a material to be used in a "mainspring", which is a drive source of mechanical watches. "SPRON" has been used for over 50 years as a drive source of watches by utilizing its high elasticity, high strength, and high heat resistance. Evaluated highly for its corrosion resistance and durable quality, "SPRON" is used for key devices in various fields.



Since 1975

**Small and powerful
Silver Oxide Battery**
"SEIZAIKEN"

A small-sized primary battery that features a large electrical capacity and almost no voltage drop until the last stage of electrical discharge even though its minimum diameter is 4 mm. Since the birth of quartz watches, we have developed batteries to increase their electrical capacity. We have also pursued better leakage resistance and long term reliability characteristics. It is expected to be used as a power supply for disposable, wearable, IoT, and the low energy Bluetooth products.



Since 1976

**Precise Timing for
Electronic Devices**
**Tuning Fork Quartz
Crystal Resonator**

Tuning Fork Quartz Crystal Resonators were developed as the basis for accuracy in the Quartz Watch. Our high quality and reliability was prioritized to meet the stringent requirements for watches. Recent demand in IoT developments where devices are required to operate with low power consumption and accurate communication protocol timing have increased the demand for smaller components with the same rugged reliability as is required in watches. For applications which require absolute lowest power consumption, our Timing Crystals are available in our Low CL specifications.



Since 1979

**Excellent heat and
corrosion resistance**
**Samarium-cobalt
Magnet**
"DIANET"

"DIANET", which has its origin in rotor magnets of quartz watches, has superior heat resistance and strong magnetic force even though its outside diameter is only 1 mm or less. The Sendai Unit acquired IATF 16949 Quality Management System for the automotive production industry. "DIANET" is used for a wide range of automotive products, and its advanced quality and performance are highly recognized. In addition, "DIANET" is also used in actuators of cameras for smart phones and medical devices.



Since 1988

Stable and reliable
**Rechargeable Battery
and Capacitor**

The rechargeable batteries supporting a wide temperature range of -40°C to 85°C are available in our lineup. They are suitable for operating very low power consumption devices, for backup power supply of clock and memory functions of a wide range of products. The capacitor will correspond to the new needs of energy harvesting devices. Capacitors are extremely useful in various applications.



Quartz Crystal Products

With Precision, we apply our Craftsmanship to provide Miniaturization advantages to customers' developed products around the world.

Features

- Mirror finishing wafer processing technology
- Manufacturing capacity for expanded wafer processing
- Largest Quartz wafer in the industry
- Extensive experience and manufacturing knowledge for Quartz tuning fork crystals

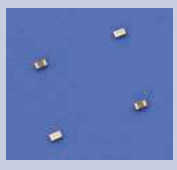
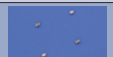
SMD type Quartz Crystal Resonator (Ceramic package)

Line up		Size (mm)	Frequency Tolerance (ppm) (*)	Parabolic Coefficient (10 ⁻⁹ /°C ²)	Load Capacitance (pF)	Motional Resistance (kΩ)	Operating Temp. (°C)	Storage Temp. (°C)	Remarks
SC-32S		3.2x1.5x0.85	±20	(-0.030±10%)	6, 7, 9, 12.5	70	-40 to +85	-55 to +125	
SC-32P		3.2x1.5x0.85	±20	(-0.033±10%)	6, 7, 9, 12.5	50	-40 to +85	-55 to +125	Low ESR type
SC-32L		3.2x1.5x0.85	±20	(-0.033±10%)	6, 7, 9, 12.5	40	-40 to +85	-55 to +125	Low ESR type
SC-32A		3.2x1.5x0.85	±20	(-0.030±10%)	6, 7, 9, 12.5	70	-55 to +125	-55 to +125	For automotive use
SC-20S		2.0x1.2x0.60	±20	(-0.030±10%)	6, 7, 9, 12.5	70	-40 to +85	-55 to +125	
SC-20P		2.0x1.2x0.60	±20	(-0.030±10%)	6, 7, 9, 12.5	50	-40 to +85	-55 to +125	Low ESR type
SC-20T		2.0x1.2x0.35	±20	(-0.033±10%)	6, 7, 9, 12.5	75	-40 to +85	-55 to +125	Low height
SC-20A		2.0x1.2x0.60	±20	(-0.028±10%)	6, 7, 9, 12.5	90	-55 to +125	-55 to +125	For automotive use
SC-16S		1.6x1.0x0.5	±20	(-0.036±10%)	6, 7, 9, 12.5	90	-40 to +85	-55 to +125	
SC-12S		1.2x1.0x0.50	±20	(-0.036±10%)	6, 7, 9, 12.5	90	-40 to +85	-55 to +125	2 terminals / 4 terminals

* Please contact us and specify your requirements.

SMD type Quartz Crystal Resonator (Plastic mold)



SSP-T7-F
SSP-T7-FL

Cylinder type Quartz Crystal Resonator

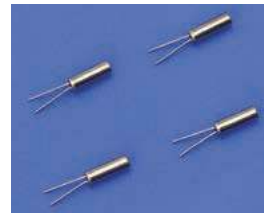

VT-200-F
VT-200-FL

SMD type Crystal Oscillator (Ceramic package)

Line up		Size (mm)	Frequency tolerance (ppm)	Frequency temperature coefficient -40 to +85°C (ppm)	Current consumption Typ. (μA)	Supply voltage (V)	Temperature Compensated voltage (V)	Operating Temp. (°C)
SH-32R		3.2x1.5x0.9	±3	±50	1.3	1.3 to 3.63	1.5 to 3.63	-40 to +85
SN-20S		2.05x1.2x0.85	+5±23	+10/-120	0.35	1.2 to 5.5		-40 to +105

Application



SC-12S

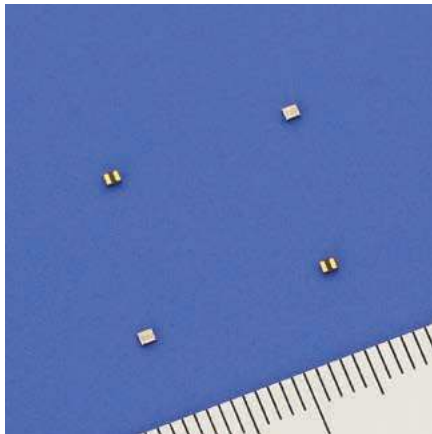

FEATURES

- Ultra small size package (1.2 × 1.0 × 0.5mm max.).
- SMD type suitable for high density surface mounting.
- Excellent shock and heat resistance.
- Pb-free.
- Complies with EU RoHS directive.
- Built-in crystal resonator processed by high reliable photo-lithographic technology.

APPLICATIONS

Mobile Phone, Wearable, Module, Sub-clock function for a variety of Microcontroller, etc.

STANDARD SPECIFICATIONS

Conditions where not specified (Temperature: 25±2°C, DL: 0.1μW)

Item	Symbol	Specifications		Conditions / Notes
		2 terminals	4 terminals	
Nominal Frequency	f_nom	32.768kHz		
Frequency Tolerance	f_tol	±20×10 ⁻⁶		* Please contact us about available tolerance.
Turnover Temperature	Ti	+25±5°C		
Parabolic Coefficient	β	(-0.036±10%) × 10 ⁻⁶ /°C ²		
Load Capacitance	C _L	6.0pF, 7.0pF, 9.0pF, 12.5pF		* Please contact us about available CL.
Motional Resistance (ESR)	R ₁	90kΩ max.		
Absolute Maximum Drive Level	DLmax.	0.3μW max.		
Level of Drive	DL	0.1μW typ.		
Shunt Capacitance	C ₀	1.4pF typ.		
Frequency Ageing	f_age	±5×10 ⁻⁶		+25±3°C, First Year
Operating Temperature	T_use	-40°C to +85°C		
Storage Temperature	T_stg	-55°C to +125°C		Storage as single product

DIMENSIONS

2 terminals

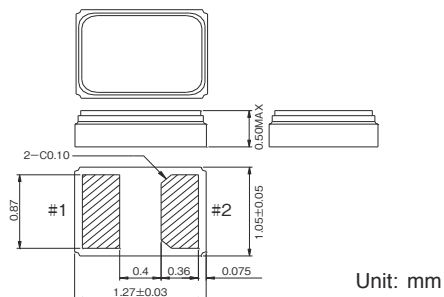

4 terminals

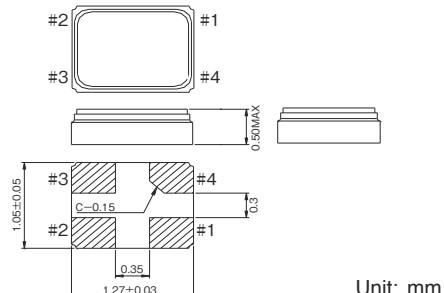

INTERNAL LEAD CONNECTION

2 terminals

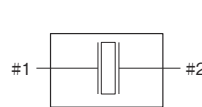

4 terminals

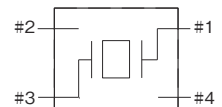

RECOMMENDED SOLDERING PATTERN

2 terminals



4 terminals

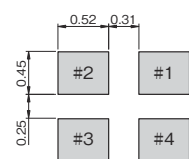

Remark Please make sure there is no pattern under SC-12S on the circuit board.

SC-16S

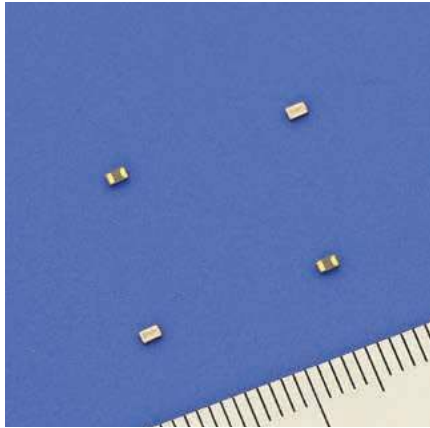

FEATURES

- SMD type suitable for high density surface mounting.
- Thin type with height 0.5mm max.
- Excellent shock and heat resistance.
- Pb-free.
- Complies with EU RoHS directive.
- Built-in crystal resonator processed by high reliable photo-lithographic technology.

APPLICATIONS

Mobile Phone, Wearable, Module, Sub-clock function for a variety of Microcontroller, etc.

STANDARD SPECIFICATIONS

Conditions where not specified (Temperature: 25±2°C, DL: 0.1μW)

Item	Symbol	Specifications	Conditions / Notes
Nominal Frequency	f_nom	32.768kHz	
Frequency Tolerance	f_tol	±20×10 ⁻⁶	* Please contact us about available tolerance.
Turnover Temperature	Ti	+25±5°C	
Parabolic Coefficient	β	(-0.036±10%)×10 ⁻⁶ /°C ²	
Load Capacitance	C _L	6.0pF, 7.0pF, 9.0pF, 12.5pF	* Please contact us about available CL.
Motional Resistance (ESR)	R ₁	90kΩ max.	
Absolute Maximum Drive Level	DLmax.	0.5μW max.	
Level of Drive	DL	0.1μW typ.	
Shunt Capacitance	C ₀	1.2pF typ.	
Frequency Ageing	f_age	±3×10 ⁻⁶	+25±3°C, First Year
Operating Temperature	T_use	-40°C to +85°C	
Storage Temperature	T_stg	-55°C to +125°C	Storage as single product

DIMENSIONS

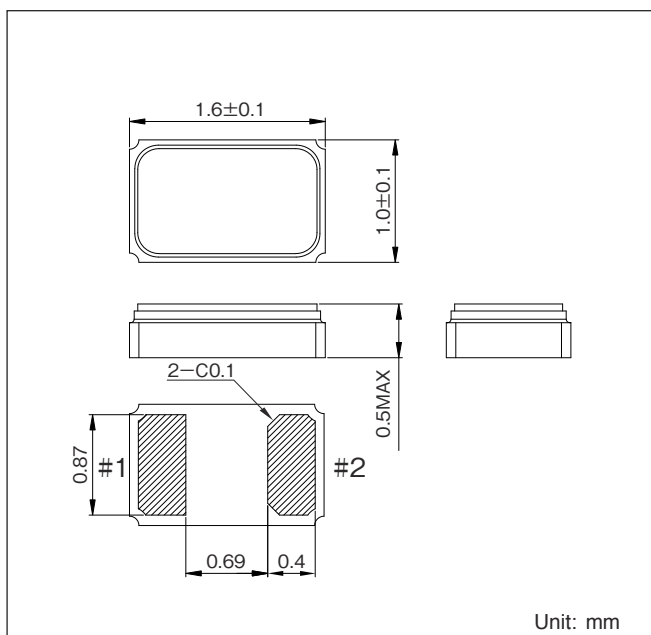

INTERNAL LEAD CONNECTION

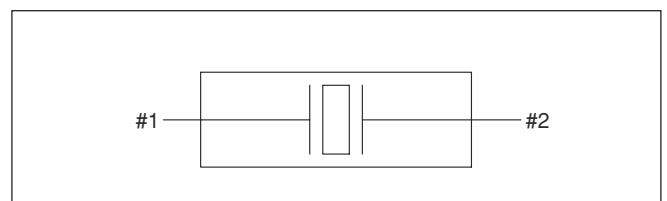

RECOMMENDED SOLDERING PATTERN

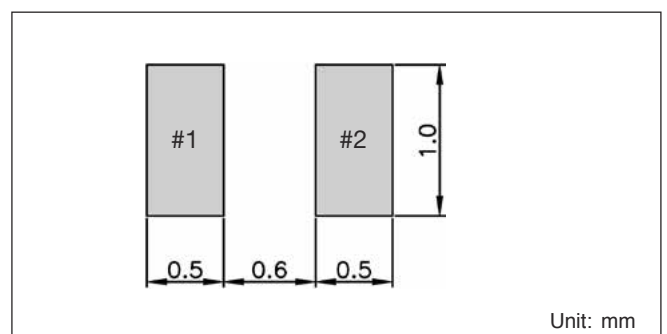

Remark Please make sure there is no pattern under SC-16S on the circuit board.

SC-20S

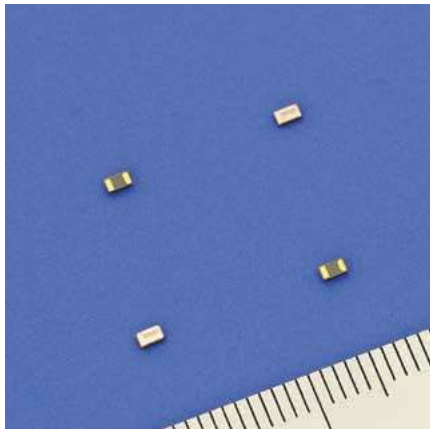

FEATURES

- Thin type with height 0.6mm max.
- SMD type suitable for high density surface mounting.
- Excellent shock and heat resistance.
- Pb-free.
- Complies with EU RoHS directive.
- Built-in crystal resonator processed by high reliable photo-lithographic technology.

APPLICATIONS

Mobile Phone, Wearable, Module, Sub-clock function for a variety of Microcontroller, etc.

STANDARD SPECIFICATIONS

Conditions where not specified (Temperature: 25±2°C, DL: 0.1μW)

Item	Symbol	Specifications	Conditions / Notes
Nominal Frequency	f_nom	32.768kHz	
Frequency Tolerance	f_tol	±20×10 ⁻⁶	* Please contact us about available tolerance.
Turnover Temperature	Ti	+25±5°C	
Parabolic Coefficient	β	(-0.030±10%)×10 ⁻⁶ /°C ²	
Load Capacitance	C _L	6.0pF, 7.0pF, 9.0pF, 12.5pF	* Please contact us about available CL.
Motional Resistance (ESR)	R ₁	70kΩ max.	
Absolute Maximum Drive Level	DLmax.	1.0μW max.	
Level of Drive	DL	0.1μW typ.	
Shunt Capacitance	C ₀	1.3pF typ.	
Frequency Ageing	f_age	±3×10 ⁻⁶	+25±3°C, First Year
Operating Temperature	T_use	-40°C to +85°C	
Storage Temperature	T_stg	-55°C to +125°C	Storage as single product

DIMENSIONS

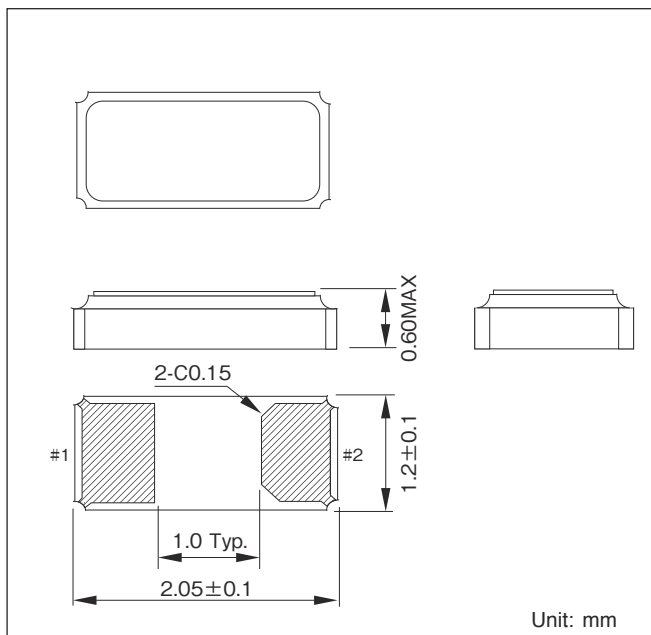

INTERNAL LEAD CONNECTION

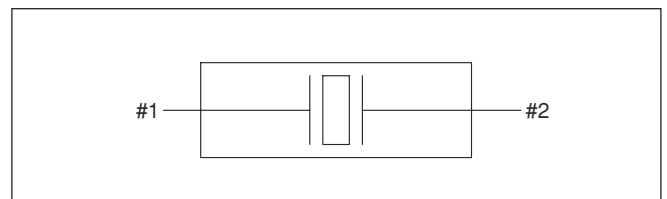

RECOMMENDED SOLDERING PATTERN

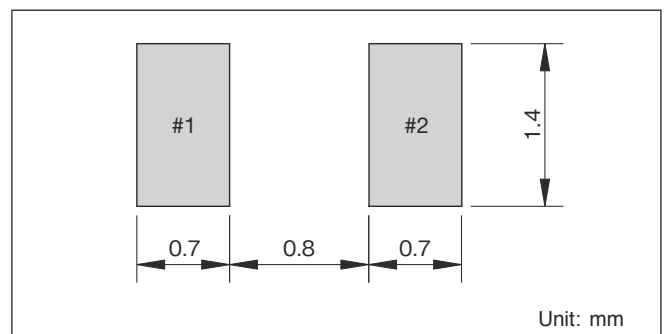

Remark Please make sure there is no pattern under SC-20S on the circuit board.

SC-20P (R1=50kΩ max.) Low ESR Series

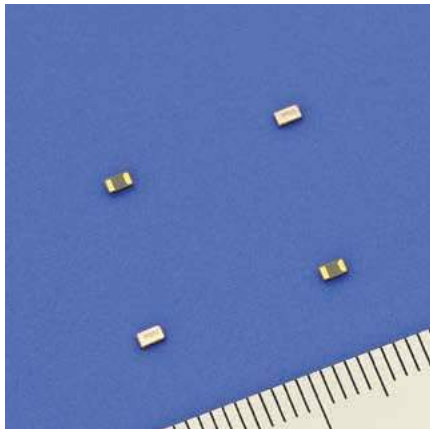

FEATURES

- Suitable for Microcontroller with Low ESR (R1=50kΩ max.).
- SMD type suitable for high density surface mounting.
- Excellent shock and heat resistance.
- Pb-free.
- Complies with EU RoHS directive.
- Built-in crystal resonator processed by high reliable photo-lithographic technology.

APPLICATIONS

PC, Tablet, Module, Wearable, Sub-clock function for a variety of Microcontroller, etc.

STANDARD SPECIFICATIONS

Conditions where not specified (Temperature: 25±2°C, DL: 0.1μW)

Item	Symbol	Specifications	Conditions / Notes
Nominal Frequency	f_nom	32.768kHz	
Frequency Tolerance	f_tol	±20×10 ⁻⁶	* Please contact us about available tolerance.
Turnover Temperature	Ti	+25±5°C	
Parabolic Coefficient	β	(-0.030±10%)×10 ⁻⁶ /°C ²	
Load Capacitance	C _L	6.0pF, 7.0pF, 9.0pF, 12.5pF	* Please contact us about available C _L .
Motional Resistance (ESR)	R ₁	50kΩ max.	-40°C to +85°C
Absolute Maximum Drive Level	DLmax.	1.0μW max.	
Level of Drive	DL	0.1μW typ.	
Shunt Capacitance	C ₀	1.5pF typ.	
Frequency Ageing	f_age	±3×10 ⁻⁶	+25±3°C, First Year
Operating Temperature	T_use	-40°C to +85°C	
Storage Temperature	T_stg	-55°C to +125°C	Storage as single product

DIMENSIONS

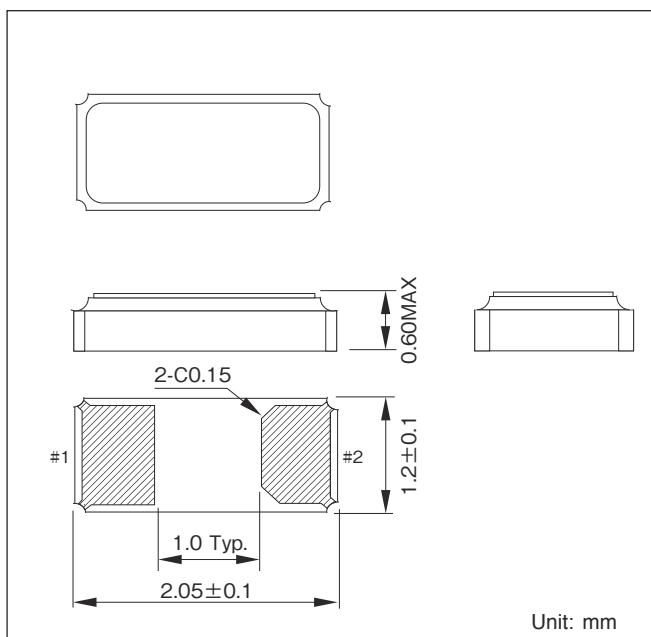

INTERNAL LEAD CONNECTION

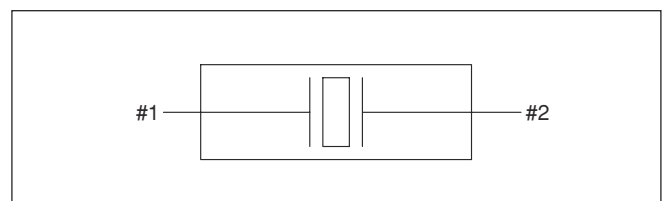

RECOMMENDED SOLDERING PATTERN

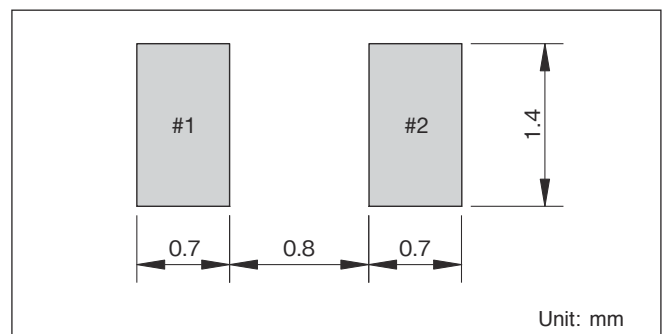

Remark Please make sure there is no pattern under SC-20P on the circuit board.

SC-20T $t=0.35\text{mm} / 0.33\text{mm}$

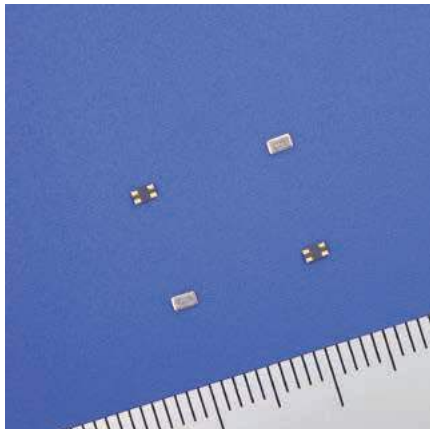

FEATURES

- Ultra thin type with height 0.35mm max.
- SMD type suitable for high density surface mounting.
- Excellent shock and heat resistance.
- Pb-free.
- Complies with EU RoHS directive.
- Built-in crystal resonator processed by high reliable photo-lithographic technology.

APPLICATIONS

Smart card, Wearable, Module, Sub-clock function for a variety of Microcontroller, etc.

STANDARD SPECIFICATIONS

Conditions where not specified (Temperature: $25\pm 2^\circ\text{C}$, DL: $0.1\mu\text{W}$)

Item	Symbol	Specifications		Conditions / Notes
		0.35mm	0.33mm	
Nominal Frequency	f_{nom}	32.768kHz		
Frequency Tolerance	f_{tol}	$\pm 20 \times 10^{-6}$		* Please contact us about available tolerance.
Turnover Temperature	T_i	$+25 \pm 5^\circ\text{C}$		
Parabolic Coefficient	β	$(-0.033 \pm 10\%) \times 10^{-6}/^\circ\text{C}^2$		
Load Capacitance	C_L	6.0pF, 7.0pF, 9.0pF, 12.5pF		* Please contact us about available CL.
Motional Resistance (ESR)	R_1	75k Ω max.	80k Ω max.	
Absolute Maximum Drive Level	DLmax.	1.0 μW max.		
Level of Drive	DL	0.1 μW typ.		
Shunt Capacitance	C_0	0.8pF typ.		
Frequency Ageing	f_{age}	$\pm 3 \times 10^{-6}$		$+25 \pm 3^\circ\text{C}$, First Year
Operating Temperature	T_{use}	-40°C to $+85^\circ\text{C}$		
Storage Temperature	T_{stg}	-55°C to $+125^\circ\text{C}$		Storage as single product

DIMENSIONS

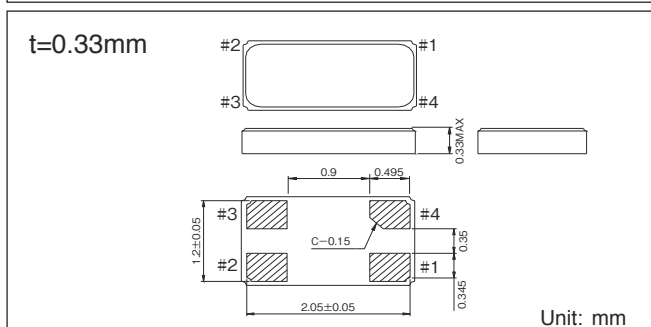
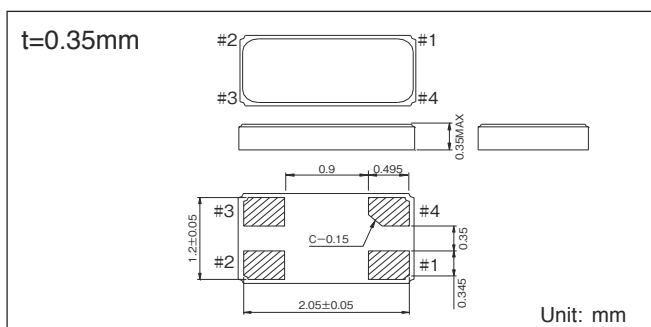

INTERNAL LEAD CONNECTION

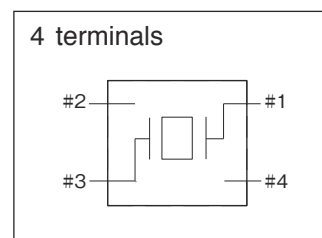

RECOMMENDED SOLDERING PATTERN

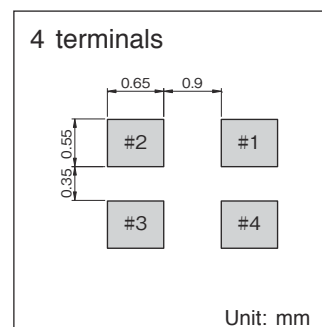

Remark Please make sure there is no pattern under SC-20T on the circuit board.

SC-20A (For automotive use)

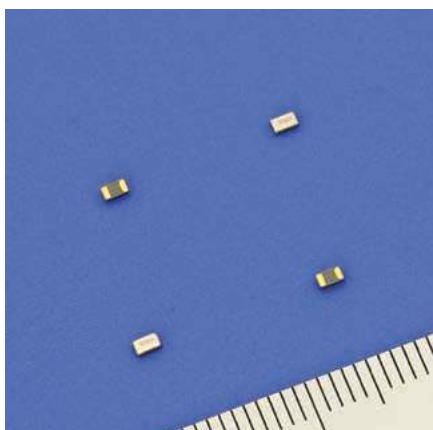

FEATURES

- Conforms to "AEC-Q200".
- Thin type with height 0.6mm max.
- SMD type suitable for high density surface mounting.
- Excellent shock and heat resistance.
- Pb-free.
- Complies with EU RoHS directive.
- Built-in crystal resonator processed by high reliable photo-lithographic technology.

APPLICATIONS

Car Audio, Car Navigation, ECU sub-clock, In-vehicle clock etc.

STANDARD SPECIFICATIONS

Conditions where not specified (Temperature: 25±2°C, DL: 0.1μW)

Item	Symbol	Specifications	Conditions / Notes
Nominal Frequency	f_nom	32.768kHz	
Frequency Tolerance	f_tol	±20×10 ⁻⁶	* Please contact us about available tolerance.
Turnover Temperature	Ti	+25±5°C	
Parabolic Coefficient	β	(-0.028±10%)×10 ⁻⁶ /°C ²	
Load Capacitance	C _L	6.0pF, 7.0pF, 9.0pF, 12.5pF	* Please contact us about available CL.
Motional Resistance (ESR)	R ₁	90kΩ max.	
Absolute Maximum Drive Level	DLmax.	1.0μW max.	
Level of Drive	DL	0.1μW typ.	
Shunt Capacitance	C ₀	1.3pF typ.	
Frequency Ageing	f_age	±3×10 ⁻⁶	+25±3°C, First Year
Operating Temperature	T_use	-55°C to +125°C	
Storage Temperature	T_stg	-55°C to +125°C	Storage as single product

DIMENSIONS

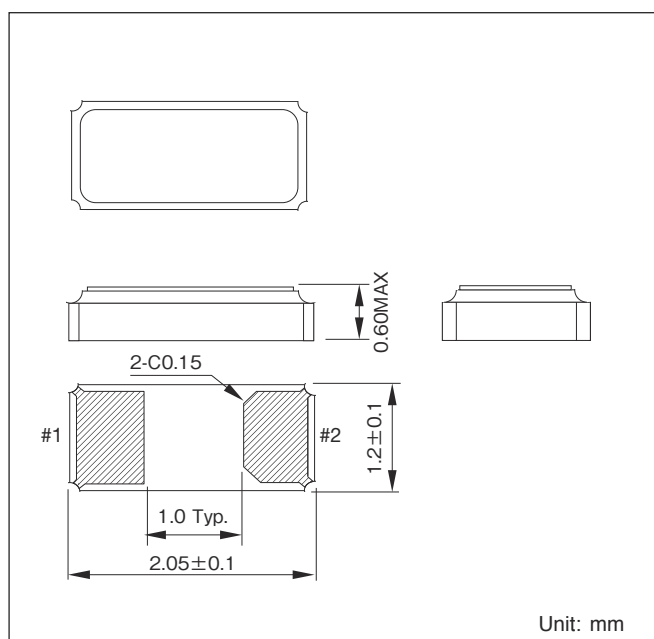

INTERNAL LEAD CONNECTION

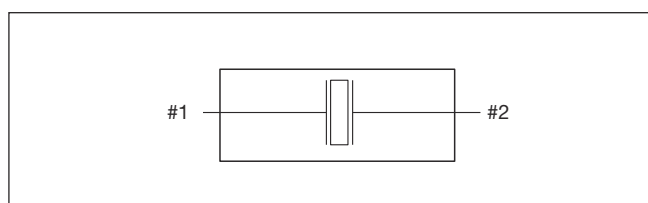

RECOMMENDED SOLDERING PATTERN

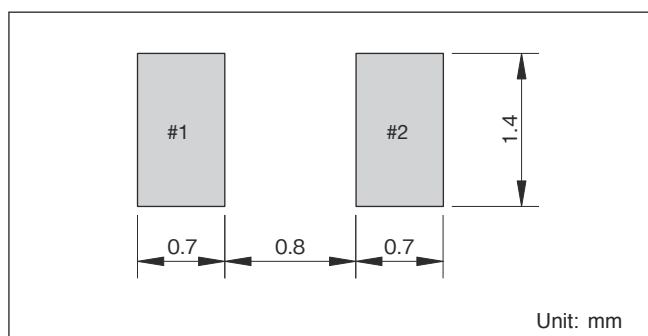

Remark Please make sure there is no pattern under SC-20A on the circuit board.

SC-32S

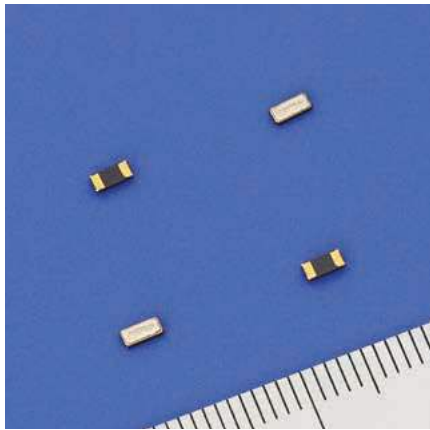

FEATURES

- Thin type with height 0.85mm max.
- SMD type suitable for high density surface mounting.
- Excellent shock and heat resistance.
- Pb-free.
- Complies with EU RoHS directive.
- Built-in crystal resonator processed by high reliable photo-lithographic technology.

APPLICATIONS

Mobile Phone, Wearable, Module, Sub-clock function for a variety of Microcontroller, etc.

STANDARD SPECIFICATIONS

Conditions where not specified (Temperature: 25±2°C, DL: 0.1μW)

Item	Symbol	Specifications		Conditions / Notes
Nominal Frequency	f _{nom}	32.768kHz	38.4kHz	
Frequency Tolerance	f _{tol}	±20×10 ⁻⁶		* Please contact us about available tolerance.
Turnover Temperature	T _i	+25±5°C		
Parabolic Coefficient	β	(-0.030±10%)×10 ⁻⁶ /°C ²		
Load Capacitance	C _L	6.0pF, 7.0pF, 9.0pF, 12.5pF		* Please contact us about available CL.
Motional Resistance (ESR)	R ₁	70kΩ max.		
Absolute Maximum Drive Level	DLmax.	1.0μW max.		
Level of Drive	DL	0.1μW typ.		
Shunt Capacitance	C ₀	1.0pF typ.		
Frequency Ageing	f _{age}	±3×10 ⁻⁶		+25±3°C, First Year
Operating Temperature	T _{use}	-40°C to +85°C		
Storage Temperature	T _{stg}	-55°C to +125°C		Storage as single product

DIMENSIONS

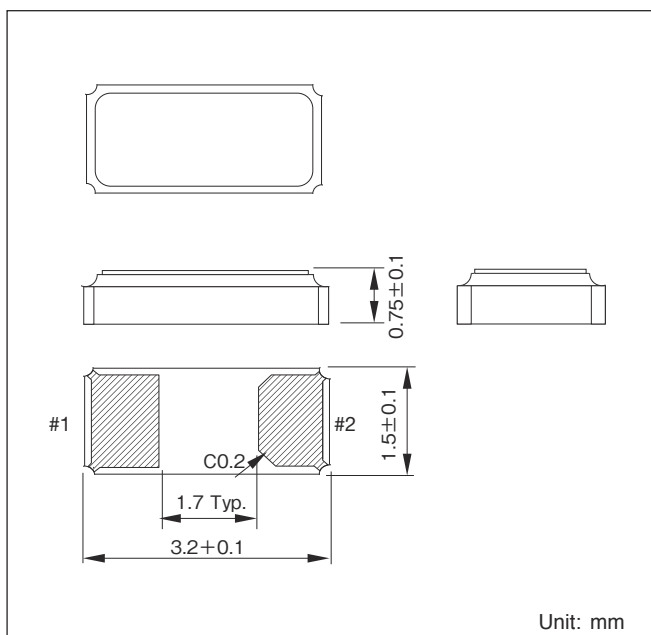

INTERNAL LEAD CONNECTION

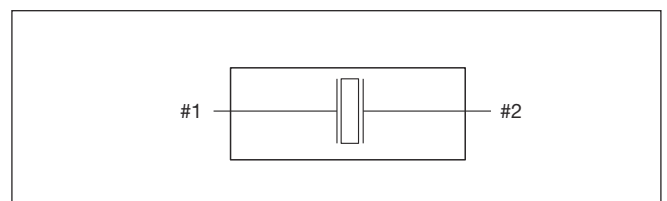

RECOMMENDED SOLDERING PATTERN

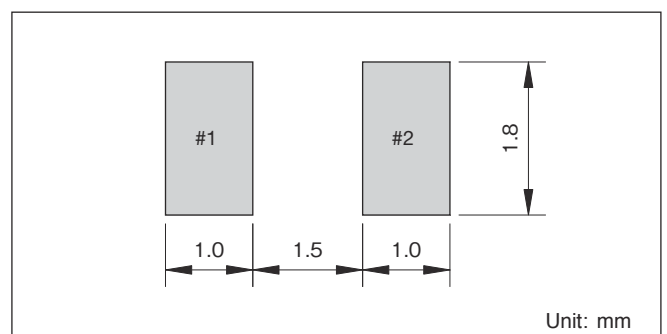

Remark Please make sure there is no pattern under SC-32S on the circuit board.

SC-32A (For automotive use)

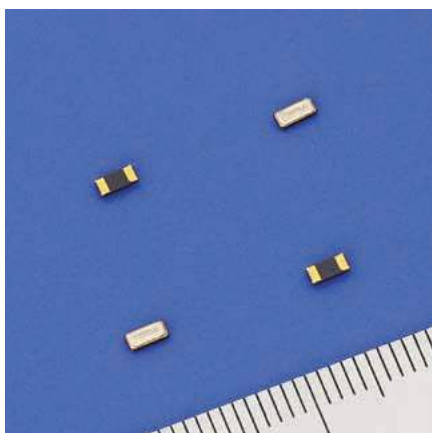

FEATURES

- Conforms to "AEC-Q200".
- SMD type suitable for high density surface mounting.
- Excellent shock and heat resistance.
- Pb-free.
- Complies with EU RoHS directive.
- Built-in crystal resonator processed by high reliable photo-lithographic technology.

APPLICATIONS

Car Audio, Car Navigation, ECU sub-clock, In-vehicle clock etc.

STANDARD SPECIFICATIONS

Conditions where not specified (Temperature: 25±2°C, DL: 0.1μW)

Item	Symbol	Specifications	Conditions / Notes
Nominal Frequency	f_nom	32.768kHz	
Frequency Tolerance	f_tol	±20×10 ⁻⁶	* Please contact us about available tolerance.
Turnover Temperature	Ti	+25±5°C	
Parabolic Coefficient	β	(-0.030±10%)×10 ⁻⁶ /°C ²	
Load Capacitance	C _L	6.0pF, 7.0pF, 9.0pF, 12.5pF	* Please contact us about available CL.
Motional Resistance (ESR)	R ₁	70kΩ max.	
Absolute Maximum Drive Level	DLmax.	1.0μW max.	
Level of Drive	DL	0.1μW typ.	
Shunt Capacitance	C ₀	1.0pF typ.	
Frequency Ageing	f_age	±3×10 ⁻⁶	+25±3°C, First Year
Operating Temperature	T_use	-55°C to +125°C	
Storage Temperature	T_stg	-55°C to +125°C	Storage as single product

DIMENSIONS

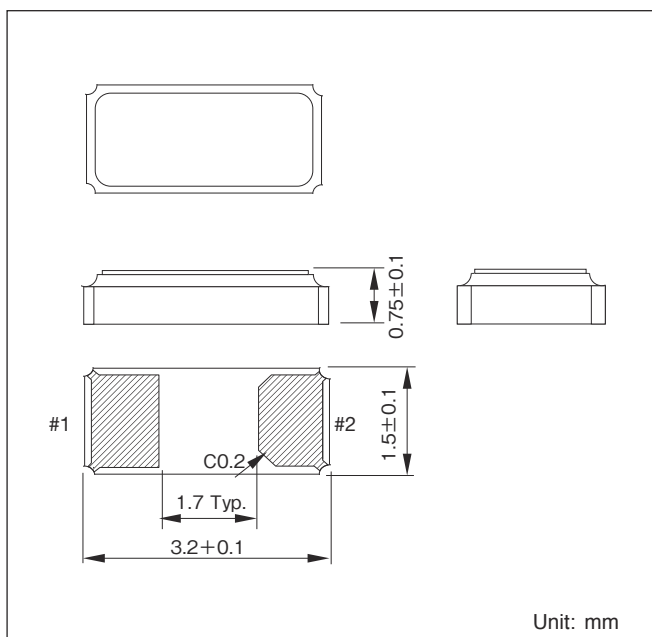

INTERNAL LEAD CONNECTION

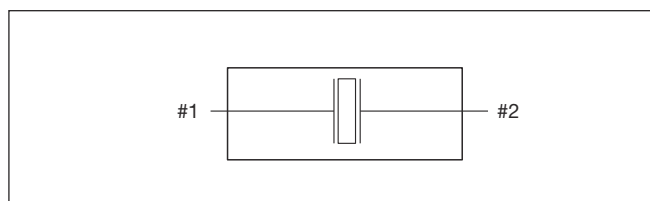

RECOMMENDED SOLDERING PATTERN

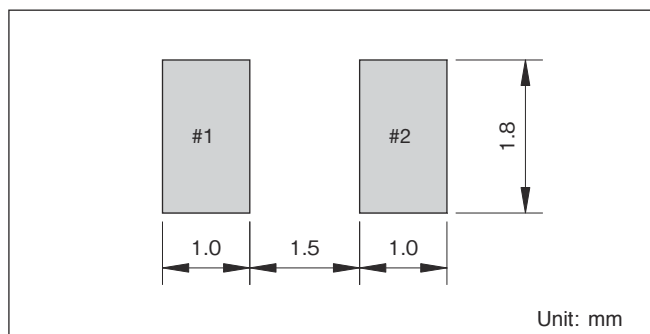

Remark Please make sure there is no pattern under SC-32A on the circuit board.

SC-32P (R1=50kΩ max.) Low ESR Series

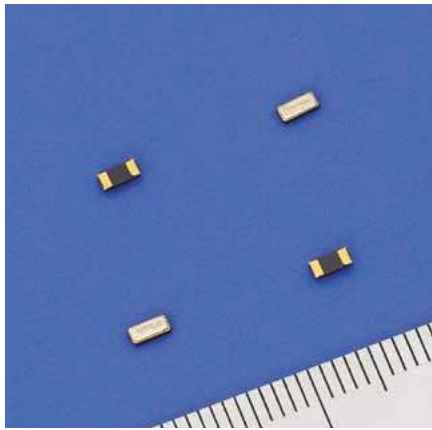

FEATURES

- Suitable for Microcontroller with Low ESR (R1=50kΩ max.).
- SMD type suitable for high density surface mounting.
- Excellent shock and heat resistance.
- Pb-free.
- Complies with EU RoHS directive.
- Built-in crystal resonator processed by high reliable photo-lithographic technology.

APPLICATIONS

PC, Tablet, Module, Wearable, Sub-clock function for a variety of Microcontroller, etc.

STANDARD SPECIFICATIONS

Conditions where not specified (Temperature: 25±2°C, DL: 0.1μW)

Item	Symbol	Specifications	Conditions / Notes
Nominal Frequency	f_nom	32.768kHz	
Frequency Tolerance	f_tol	±20×10 ⁻⁶	* Please contact us about available tolerance.
Turnover Temperature	Ti	+25±5°C	
Parabolic Coefficient	β	(-0.033±10%)×10 ⁻⁶ /°C ²	
Load Capacitance	C _L	6.0pF, 7.0pF, 9.0pF, 12.5pF	* Please contact us about available CL.
Motional Resistance (ESR)	R ₁	50kΩ max.	-40°C to +85°C
Absolute Maximum Drive Level	DLmax.	1.0μW max.	
Level of Drive	DL	0.1μW typ.	
Shunt Capacitance	C ₀	1.0pF typ.	
Frequency Ageing	f_age	±3×10 ⁻⁶	+25±3°C, First Year
Operating Temperature	T_use	-40°C to +85°C	
Storage Temperature	T_stg	-55°C to +125°C	Storage as single product

DIMENSIONS

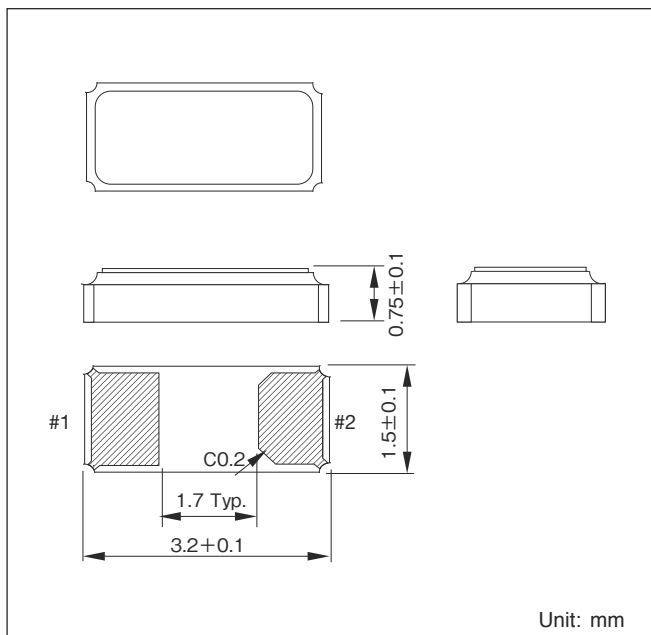

INTERNAL LEAD CONNECTION

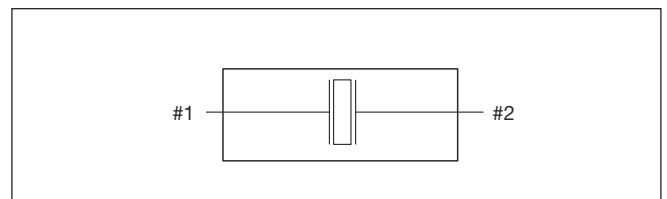

RECOMMENDED SOLDERING PATTERN

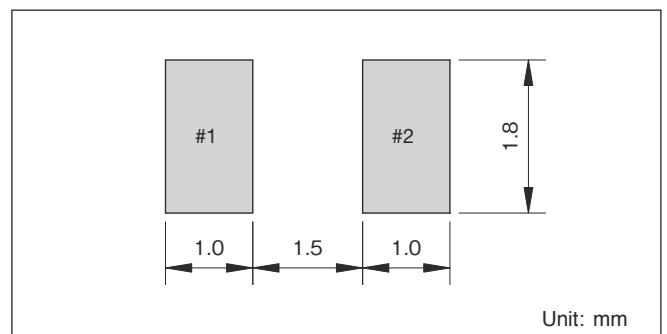

Remark Please make sure there is no pattern under SC-32P on the circuit board.

SC-32L (R1=40kΩ max.) Low ESR Series

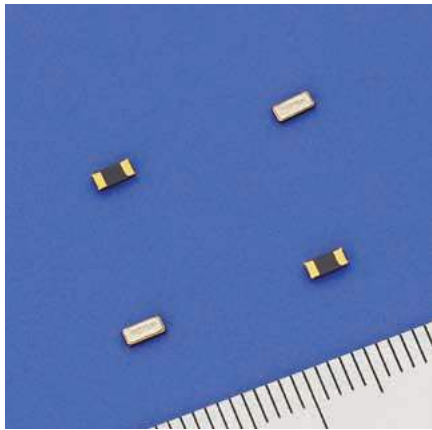

FEATURES

- Suitable for Microcontroller with Low ESR (R1=40kΩ max.).
- SMD type suitable for high density surface mounting.
- Excellent shock and heat resistance.
- Pb-free.
- Complies with EU RoHS directive.
- Built-in crystal resonator processed by high reliable photo-lithographic technology.

APPLICATIONS

PC, Tablet, Module, Wearable, Sub-clock function for a variety of Microcontroller, etc.

STANDARD SPECIFICATIONS

Conditions where not specified (Temperature: 25±2°C, DL: 0.1μW)

Item	Symbol	Specifications	Conditions / Notes
Nominal Frequency	f_nom	32.768kHz	
Frequency Tolerance	f_tol	±20×10 ⁻⁶	* Please contact us about available tolerance.
Turnover Temperature	Ti	+25±5°C	
Parabolic Coefficient	β	(-0.033±10%)×10 ⁻⁶ /°C ²	
Load Capacitance	C _L	6.0pF, 7.0pF, 9.0pF, 12.5pF	* Please contact us about available CL.
Motional Resistance (ESR)	R ₁	40kΩ max.	-40°C to +85°C
Absolute Maximum Drive Level	DLmax.	1.0μW max.	
Level of Drive	DL	0.1μW typ.	
Shunt Capacitance	C ₀	1.2pF typ.	
Frequency Ageing	f_age	±3×10 ⁻⁶	+25±3°C, First Year
Operating Temperature	T_use	-40°C to +85°C	
Storage Temperature	T_stg	-55°C to +125°C	Storage as single product

DIMENSIONS

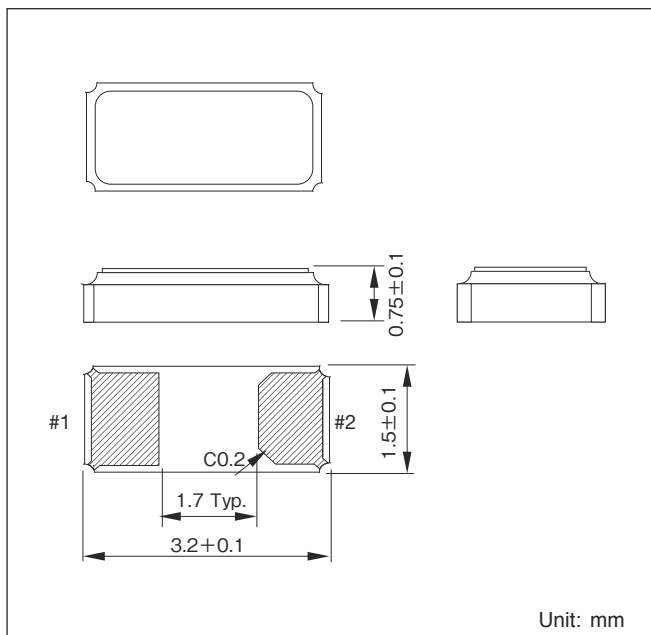

INTERNAL LEAD CONNECTION

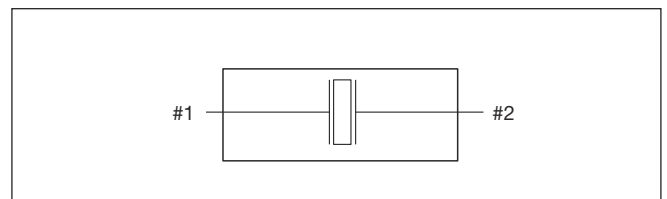

RECOMMENDED SOLDERING PATTERN

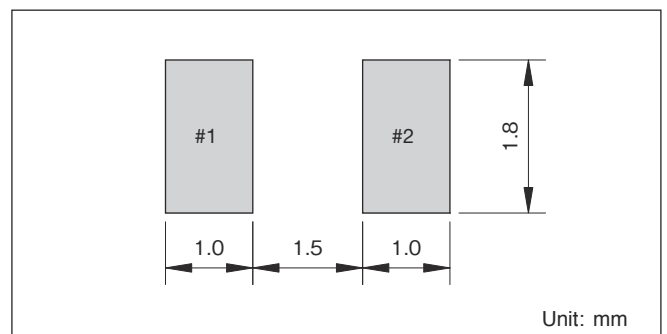

Remark Please make sure there is no pattern under SC-32L on the circuit board.

SSP-T7-F

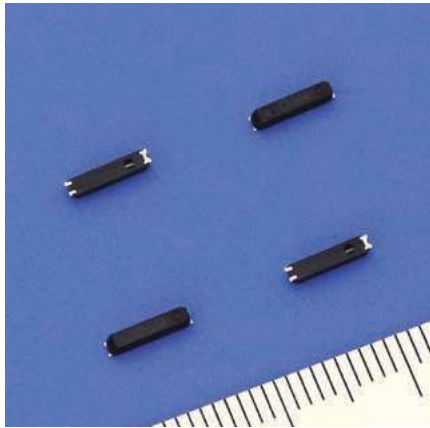

FEATURES

- Thin type with height 1.4mm max.
- SMD type suitable for high density surface mounting.
- Excellent shock and heat resistance.
- Complies with EU RoHS directive.
- Complete Halogen-free.
- Built-in crystal resonator processed by high reliable photo-lithographic technology.

APPLICATIONS

Clock for time display and timer, Power/water meter, Sub-clock function for a variety of Microcontroller, etc

STANDARD SPECIFICATIONS

Conditions where not specified (Temperature: 25±2°C, DL: 0.1μW)

Item	Symbol	Specifications	Conditions / Notes
Nominal Frequency	f_nom	32.768kHz	
Frequency Tolerance	f_tol	±20×10 ⁻⁶	* Please contact us about available tolerance.
Turnover Temperature	Ti	+25±5°C	
Parabolic Coefficient	β	(-0.033±10%)×10 ⁻⁶ /°C ²	
Load Capacitance	C _L	7.0pF, 9.0pF, 12.5pF	* Please contact us about available CL.
Motional Resistance (ESR)	R ₁	65kΩ max.	
Absolute Maximum Drive Level	DLmax.	1.0μW max.	
Level of Drive	DL	0.1μW typ.	
Shunt Capacitance	C ₀	0.9pF typ.	
Frequency Ageing	f_age	±3×10 ⁻⁶	+25±3°C, First Year
Operating Temperature	T_use	-40°C to +85°C	
Storage Temperature	T_stg	-55°C to +125°C	Storage as single product

DIMENSIONS

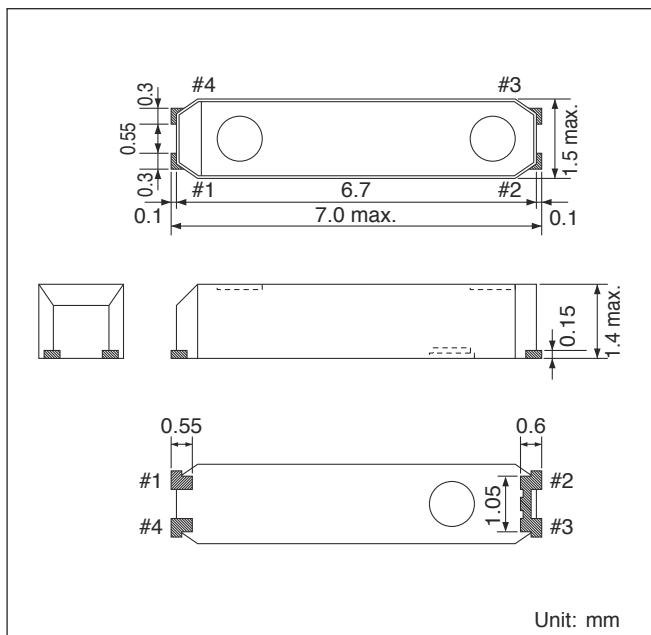

INTERNAL LEAD CONNECTION

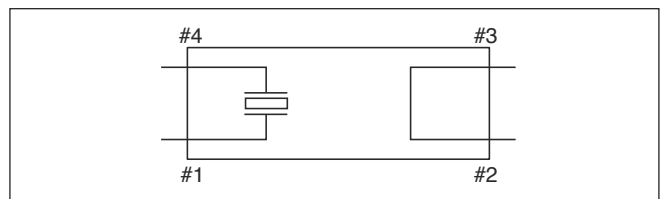

RECOMMENDED SOLDERING PATTERN

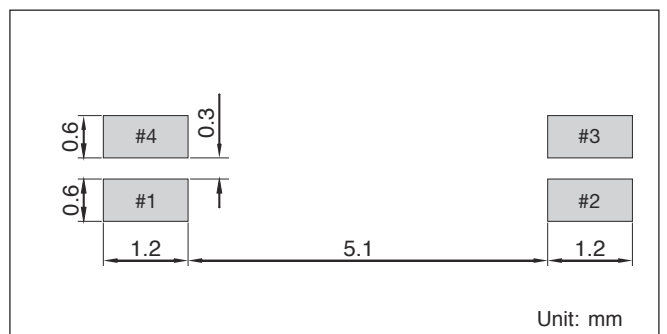

Remark Please make sure there is no pattern under SSP-T7-F on the circuit board.

SSP-T7-FL (SMD type low CL resonator for low-power microcontrollers)

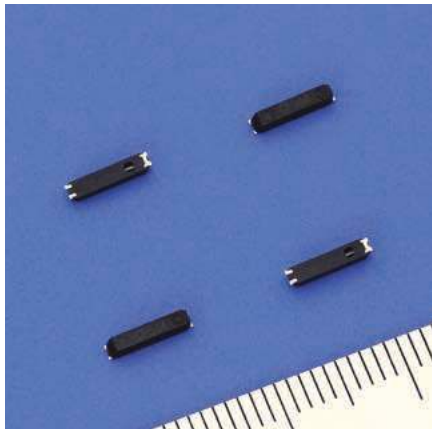

FEATURES

- Consumes one tenth the standby power of general crystal resonators (with a load capacitance of 12.5 pF) (*1).
 - Excellent low drive characteristics.
 - Complies with EU RoHS directive.
 - Built-in crystal resonator processed by high reliable photo-lithographic technology.
- (*1) When using a microcontroller that supports low CL.

APPLICATIONS

- Consumer electronics products for saving standby energy consumption.
- The devices which is operated by the battery requiring a long battery life.

STANDARD SPECIFICATIONS

Conditions where not specified (Temperature: 25±2°C, DL: 0.01μW)

Item	Symbol	Specifications	Conditions / Notes
Nominal Frequency	f_nom	32.768kHz	
Frequency Tolerance	f_tol	±20×10 ⁻⁶	* Please contact us about available tolerance.
Turnover Temperature	Ti	+25±5°C	
Parabolic Coefficient	β	(-0.033±10%)×10 ⁻⁶ /°C ²	
Load Capacitance	C _L	3.7pF, 4.4pF, 6.0pF	* Please contact us about available CL.
Motional Resistance (ESR)	R ₁	65kΩ max.	
Absolute Maximum Drive Level	DLmax.	1.0μW max.	
Level of Drive	DL	0.01μW typ.	
Shunt Capacitance	C ₀	0.9pF typ.	
Frequency Ageing	f_age	±3×10 ⁻⁶	+25±3°C, First Year
Operating Temperature	T_use	-40°C to +85°C	
Storage Temperature	T_stg	-55°C to +125°C	Storage as single product

DIMENSIONS

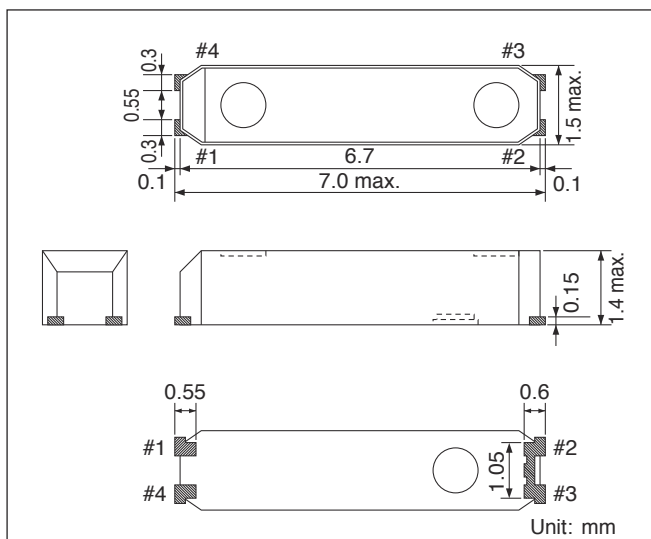

INTERNAL LEAD CONNECTION

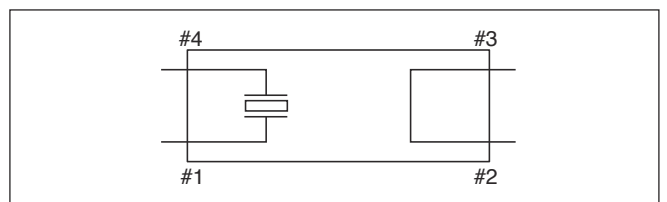

RECOMMENDED SOLDERING PATTERN

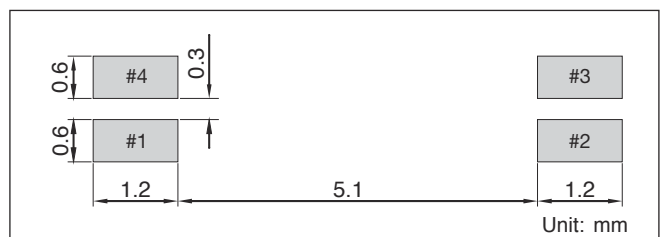

Remark Please make sure there is no pattern under SSP-T7-FL on the circuit board.

CAUTION

The SSP-T7-FL is designed for use in ultra-low-power microcontrollers. Do not use this resonator in regular microcontrollers as it might cause problems with oscillation.

VT-200-F

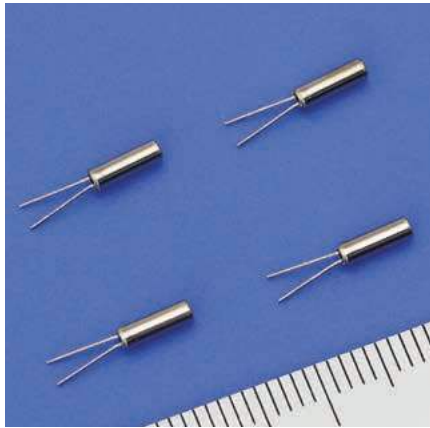

FEATURES

- 2.0Φ tubular package.
- Built-in crystal resonator processed by high reliable photo-lithographic technology.
- Excellent shock resistance and environmental characteristics.
- Pb-free.
- Complies with EU RoHS directive.

APPLICATIONS

Clocks, Timers, Water/Electricity Meters,
Remote controllers,
Sub-clock function for a variety of Microcontroller, etc.

STANDARD SPECIFICATIONS

Conditions where not specified (Temperature: 25±2°C, DL: 0.1μW)

Item	Symbol	Specifications	Conditions / Notes
Nominal Frequency	f_nom	32.768kHz	
Frequency Tolerance	f_tol	±20×10 ⁻⁶	* Please contact us about available tolerance.
Turnover Temperature	Ti	+25±5°C	
Parabolic Coefficient	β	(-0.035±10%)×10 ⁻⁶ /°C ²	
Load Capacitance	C _L	7.0pF, 9.0pF, 12.5pF	* Please contact us about available CL.
Motional Resistance (ESR)	R ₁	50kΩ max.	
Absolute Maximum Drive Level	DLmax.	1.0μW max.	
Level of Drive	DL	0.1μW typ.	
Shunt Capacitance	C ₀	0.9pF typ.	
Frequency Ageing	f_age	±3×10 ⁻⁶	+25±3°C, First Year
Operating Temperature	T_use	-40°C to +85°C	
Storage Temperature	T_stg	-40°C to +85°C	Storage as single product

DIMENSIONS

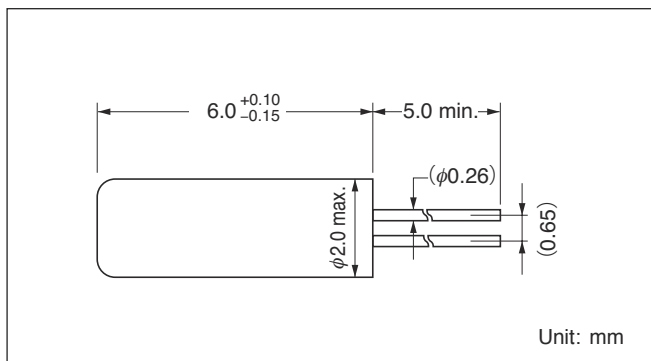

Remark Please make sure there is no pattern under VT-200-F on the circuit board.

VT-200-FL (Cylinder type low CL resonator for low-power microcontrollers)

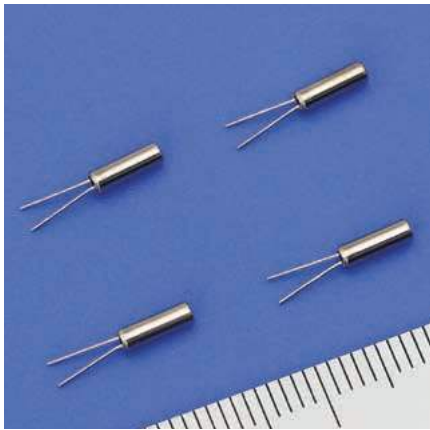

FEATURES

- Consumes one tenth the standby power of general crystal resonators (with a load capacitance of 12.5 pF) (*1).
 - Built-in crystal resonator processed by high reliable photo-lithographic technology.
 - Excellent low drive characteristics.
 - Pb-free.
 - Complies with EU RoHS directive.
- (*1) When using a microcontroller that supports low CL.

APPLICATIONS

- Consumer-electronics products for saving standby energy consumption.
- The devices which is operated by the battery requiring a long battery life.

STANDARD SPECIFICATIONS

Conditions where not specified (Temperature: 25±2°C, DL: 0.01μW)

Item	Symbol	Specifications	Conditions / Notes
Nominal Frequency	f_nom	32.768kHz	
Frequency Tolerance	f_tol	±20×10 ⁻⁶	* Please contact us about available tolerance.
Turnover Temperature	Ti	+25±5°C	
Parabolic Coefficient	β	(-0.035±10%)×10 ⁻⁶ /°C ²	
Load Capacitance	C _L	3.7pF, 4.4pF, 6.0pF	* Please contact us about available CL.
Motional Resistance (ESR)	R ₁	50kΩ max.	
Absolute Maximum Drive Level	DLmax.	1.0μW max.	
Level of Drive	DL	0.01μW typ.	
Shunt Capacitance	C ₀	0.9pF typ.	
Frequency Ageing	f_age	±3×10 ⁻⁶	+25±3°C, First Year
Operating Temperature	T_use	-40°C to +85°C	
Storage Temperature	T_stg	-40°C to +85°C	Storage as single product

DIMENSIONS

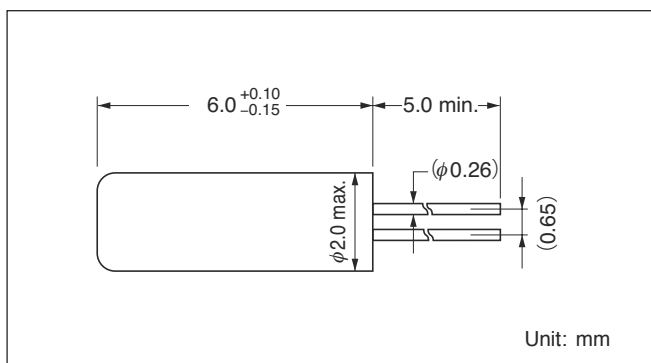

Remark Please make sure there is no pattern under VT-200-FL on the circuit board.

CAUTION

The VT-200-FL is designed for use in ultra-low-power microcontrollers. Do not use this resonator in regular microcontrollers as it might cause problems with oscillation.

Crystal Oscillator 32.768kHz SN-20S

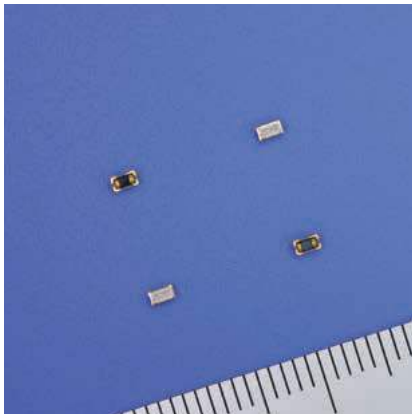

FEATURES

- Small size package (2.0x1.2x0.85mm)
- Ultra low current consumption 0.5μA Typ. (V_{DD}=3.3V)
- Pb-free
- Built-in crystal resonator processed by high reliable photo-lithographic technology.

APPLICATIONS

Wearable, Module, Sub-clock function for a variety of Microcontroller, etc.

STANDARD SPECIFICATIONS

Item	Symbol	Specifications	Unit	Conditions / Notes
Nominal Frequency	f _{nom}	32.768	kHz	
Voltage	V _{DD}	1.2 to 5.5	V	
Storage Temperature	T _{stg}	-55 to +125	°C	
Operating Temperature	T _{use}	-40 to +105	°C	
Frequency tolerance	f _{tol}	5±23	×10 ⁻⁶	+25°C, V _{DD} =3.3V
Frequency temperature coefficient	f ₀ -Tc	+10/-120	×10 ⁻⁶	-20 to +70°C (+25°C is reference)
Frequency / voltage coefficient	f ₀ -V _{DD}	±3	×10 ⁻⁶ /V	+25°C, V _{DD} =1.2 to 5.5V
Current consumption	I _{DD}	0.35 Typ./0.65 Max.(105°C)	μA	V _{DD} =1.8V, No load condition
		0.50 Typ./0.80 Max.(105°C)	μA	V _{DD} =3.3V, No load condition
Current consumption(sleep)	I _{DD2}	0.25 Typ./0.60 Max.(105°C)	μA	V _{DD} =1.2 to 5.5V, No load condition
Symmetry	SYM	50±10	%	Load : 15pF
Rise time / Fall time	tr/tf	200 Max.	ns	Load : 15pF, output level 10 to 90%
Input voltage	V _{IL}	0.2V _{DD} Max.	V	OE terminal
	V _{IH}	0.8V _{DD} Min.	V	OE terminal
Output voltage	V _{OL}	0.4 Max.	V	I _{OL} =0.4mA
	V _{OH}	V _{DD} -0.4 Min.	V	I _{OH} =-0.4mA
Output load condition (CMOS)	C _{LOUT}	15 Max.	pF	CMOS Loading
Start-up time	t _{str}	0.15 Typ./0.50 Max.	sec	
Frequency aging	f _{aging}	±3	×10 ⁻⁶	+25°C, V _{DD} =3.3V, First Year

Unless otherwise stated, characteristics (specifications) shown in the above table are based on the rated operating temperature and voltage condition.

DIMENSIONS

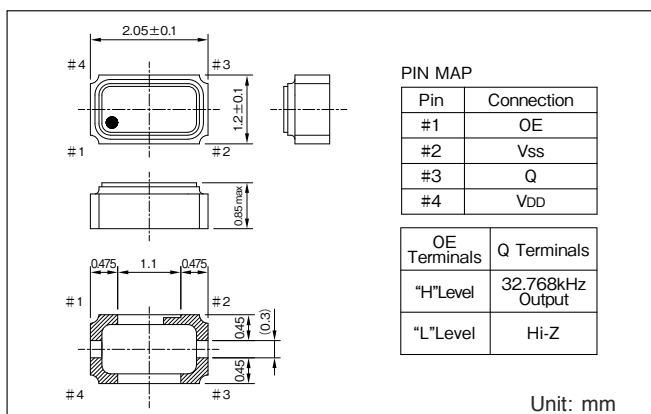

RECOMMENDED SOLDERING PATTERN

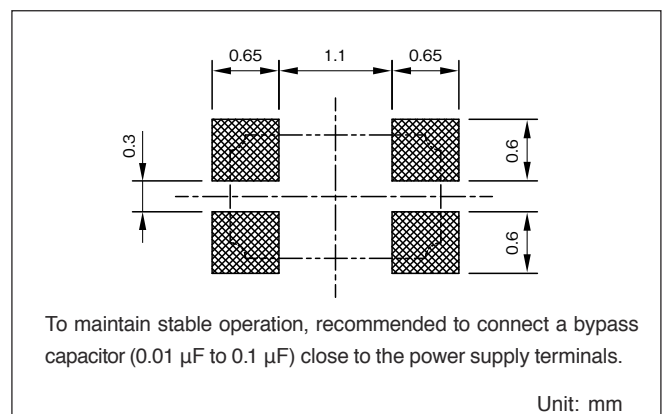

High Accuracy Crystal Oscillator 32.768kHz SH-32R

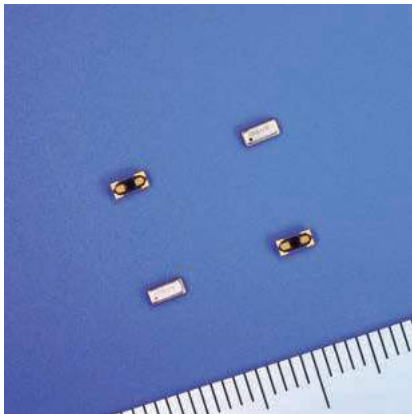

FEATURES

- Excellent frequency accuracy and Temperature characteristics
- Low current consumption
- Pb-free
- Incorporated highly reliable photolithographic crystal resonator

APPLICATIONS

Smart Meter, IoT, Wearable device, Industry device, High precision timing device, Event data recorder

STANDARD SPECIFICATIONS

Item	Symbol	Specifications	Unit	Conditions / Notes
Nominal Frequency	f_nom	32.768	kHz	
Voltage	Supply	1.3 to 3.63	V	(*1)
	Temperature Compensated	1.5 to 3.63	V	
Temperature range	Storage	-40 to +105	°C	
	Operating	-40 to +85	°C	
Frequency Tolerance	f_tol	±3	×10 ⁻⁶	+25°C, V _{DD} =3.3V
Temperature range	f0-Tc	±50	×10 ⁻⁶	-40 to +85°C (+25°C is reference)
Frequency / voltage coefficient	f0_V _{DD}	±1	×10 ⁻⁶ /V	+25°C, V _{DD} =1.5 to 3.63V
Current consumption	I _{DD}	1.3 Typ.	μA	V _{DD} =3.3V, No load condition
		2.5 Max.	μA	
Symmetry	SYM	40/60	%	Load : 30pF
Rise time / Fall time	tr/tf	40 Max.	ns	Load : 30pF, output level 10 to 90%
Input voltage	V _{IL}	0.2V _{DD} Max.	V	OE terminal
	V _{IH}	0.8V _{DD} Min.	V	OE terminal
Output voltage	V _{OL}	0.1V _{DD} Max.	V	I _{OL} =0.1mA, V _{DD} =1.5V
	V _{OH}	0.9V _{DD} Min.	V	I _{OH} =-0.1mA, V _{DD} =1.5V
Output load condition (CMOS)	C _{LOUT}	30 Max.	pF	CMOS Loading
Start-up time	t_str	0.5 Max.	sec	
Frequency aging	f_aging	±3	×10 ⁻⁶	+25°C, V _{DD} =3.3V, First Year

Unless otherwise stated, characteristics (specifications) shown in the above table are based on the rated operating temperature and voltage condition. (*1) When the supply voltage becomes under 1.5V, the frequency temperature compensation operation is inactivated.

DIMENSIONS

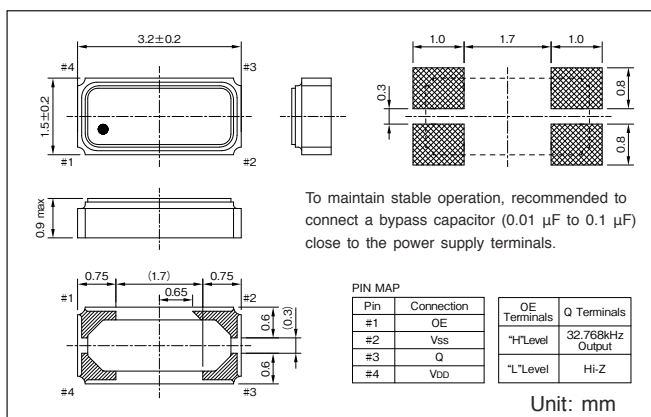

TEMPERATURE CHARACTERISTIC

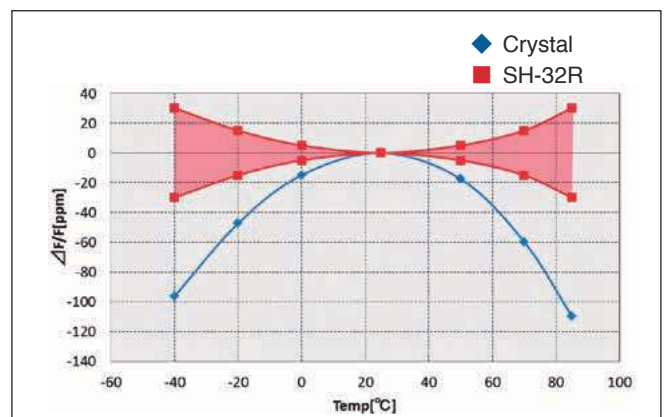

Check sheet for crystal products selection

When considering our crystal resonator / oscillator, please inform the following items. We will propose applications, characteristics etc. of the usage conditions.

1. Products of interest

- | | | | |
|------------------------------------|-----------------------------------|------------------------------------|---------------------------------|
| (1) Cylinder type resonator | <input type="checkbox"/> VT-200-F | <input type="checkbox"/> VT-200-FL | |
| (2) Plastic mold type resonator | <input type="checkbox"/> SSP-T7-F | <input type="checkbox"/> SSP-T7-FL | |
| (3) Ceramic package type resonator | <input type="checkbox"/> SC-32S | <input type="checkbox"/> SC-32A | <input type="checkbox"/> SC-32P |
| | <input type="checkbox"/> SC-32L | <input type="checkbox"/> SC-20S | <input type="checkbox"/> SC-20A |
| | <input type="checkbox"/> SC-20P | <input type="checkbox"/> SC-20T | <input type="checkbox"/> SC-16S |
| | <input type="checkbox"/> SC-12S | | |
| (4) Oscillator | <input type="checkbox"/> SH-32R | <input type="checkbox"/> SN-20S | |

2. Applications

3. Semiconductors usage

- (1) Semiconductors
- | | | | |
|--|-------------------------------|------------------------------|---------------------------------|
| <input type="checkbox"/> Microcontroller | <input type="checkbox"/> ASIC | <input type="checkbox"/> RTC | <input type="checkbox"/> Others |
|--|-------------------------------|------------------------------|---------------------------------|
- Manufacturer product name _____
- (2) Purpose of usage
- | | | |
|--------------------------------------|-----------------------------------|--|
| <input type="checkbox"/> Timekeeping | <input type="checkbox"/> Stand-by | <input type="checkbox"/> Communication |
|--------------------------------------|-----------------------------------|--|
- Others _____

4. Required specification for the resonator

- (1) Nominal Frequency (f_{nom})
- | | |
|------------------------------------|---|
| <input type="checkbox"/> 32.768kHz | <input type="checkbox"/> Others _____ kHz |
|------------------------------------|---|
- (2) Operating Temperature (T_{use})
- | | |
|---------------------------------------|--|
| <input type="checkbox"/> -40 to +85°C | <input type="checkbox"/> Others _____ °C |
|---------------------------------------|--|
- (3) Frequency Tolerance ($25\pm 2^\circ\text{C}$) (f_{tol})
- | | | |
|---------------------------------------|---------------------------------------|--------------------------------------|
| <input type="checkbox"/> ± 20 ppm | <input type="checkbox"/> ± 10 ppm | <input type="checkbox"/> ± 5 ppm |
|---------------------------------------|---------------------------------------|--------------------------------------|
- Others _____ ppm
- (4) Load Capacitance (C_L)
- | | | | |
|---------------------------------|------------------------------|------------------------------|------------------------------|
| <input type="checkbox"/> 12.5pF | <input type="checkbox"/> 9pF | <input type="checkbox"/> 7pF | <input type="checkbox"/> 6pF |
|---------------------------------|------------------------------|------------------------------|------------------------------|
- Others _____ pF
- (5) Number of terminals (For SC-12S)
- | | |
|--------------------------------------|--------------------------------------|
| <input type="checkbox"/> 2 terminals | <input type="checkbox"/> 4 terminals |
|--------------------------------------|--------------------------------------|

5. Required specification for the oscillator

- (1) Frequency-temperature coefficient (fo_{Tc})
- | | |
|--|--|
| <input type="checkbox"/> ± 50 ppm (-40 to +85°C) | <input type="checkbox"/> ± 40 ppm (-20 to +70°C) |
| <input type="checkbox"/> ± 30 ppm (-10 to +60°C) | <input type="checkbox"/> ± 20 ppm (0 to +50°C) |

6. Special requirement

e.g.) Automotive usage or medical device usage or special quality requirement.

7. Others

SII Group Environmental Policy

Environmental Concept

The SII Group will continue to harmonize its corporate activities with the global environment, designate the “Three Green” concept consisting of Green Process, Green Products and Green Life as our basic concept, promote and conduct environmental activities, and contribute to the establishment of a sustainable society that can coexist with nature.

Environmental Activity Guidelines

We will strive to

1. Continue to improve our environmental management system and environmental performance, while performing advanced activities that respond to the requirements of society to enhance stakeholder value.
2. Not only observe all laws, rules, regulations, agreements and other duties, but also mitigate environmental risks and prevent environmental pollution.
3. Carry out our tasks with a focus on the following activities based on “SYO”ism*1:
 - (1) Providing products and services that minimize their impact on the environment throughout their lifecycles and can contribute to environmental conservation.
 - (2) Proactively promoting eco-friendly, efficient manufacturing.
 - (3) Fully enforcing energy conservation measures in the entire business activities and addressing global warming.
 - (4) Recognizing the finite nature and the preciousness of resources of the earth, and encouraging their responsible use.
 - (5) Reducing risks arising from chemical substances and promoting the elimination of harmful substances.
4. Promote SII Green Purchasing and ensure proper and strict management of chemical substances contained in products.
5. Be aware of our impact on biodiversity and all the benefits we receive from it, and make efforts toward biodiversity conservation.
6. Raise environmental awareness of all employees and encourage them to protect the environment in their personal lives.
7. Make a social contribution to and achieve accountability for environmental protection, while facilitating communication with the society.
8. Ask our suppliers for their cooperation in following this policy.

*1 “SYO”ism: SII technology philosophy



This mark means that the product complies with SII's own environmental standards.

Quartz Crystal Unit Handling Precautions

1. MOUNTING PRECAUTIONS Lead Type Crystal Units

• Structure

Tubular crystal units (VT) are hermetically sealed using glass (see Figures 1 and 2).

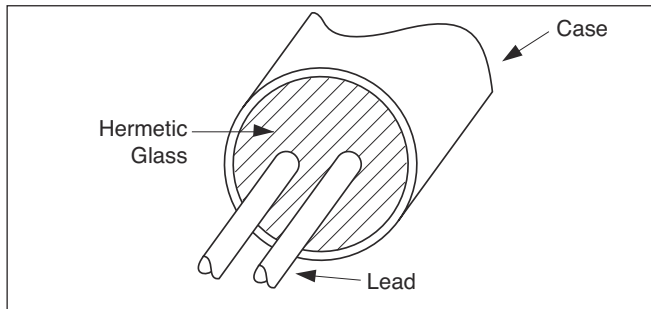

Figure 1

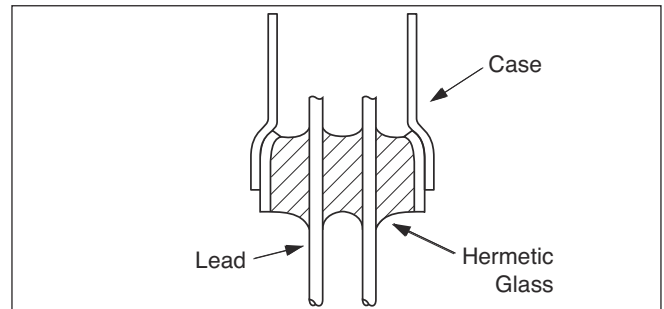

Figure 2

• Unbending the lead

(1) DO NOT pull the lead excessively if unbending a lead or removing a crystal unit. The excessive force may crack the glass and reduce the degree of vacuum. This may eventually result in deterioration of the characteristics and may also break the crystal chip (see Figure 3).

(2) Unbend the lead by pressing on the bent part from both the upper and lower sides with fixing the bottom of lead tightly (see Figure 4).

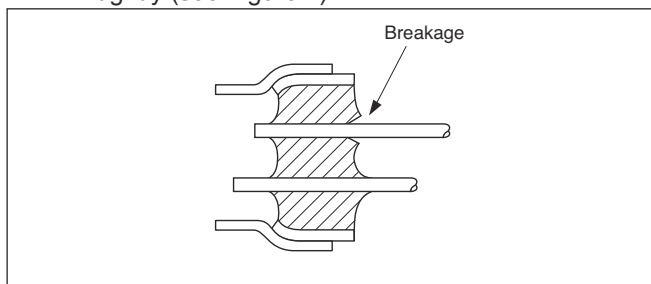

Figure 3

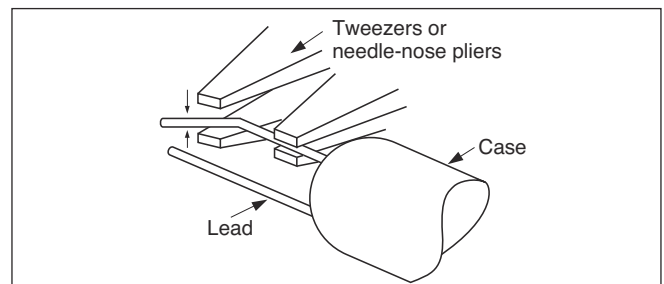

Figure 4

• Bending the lead

(1) Bend the lead so that the lead will remain straight for more than 0.5mm from the case when soldering a crystal unit after bending. If not, the glass may be cracked (see Figures 5 and 6).

(2) Always leave a length greater than 2.0mm when bending a lead after soldering (see Figure 7).

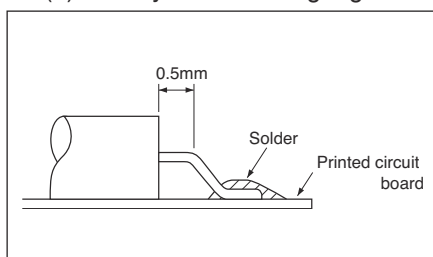

Figure 5

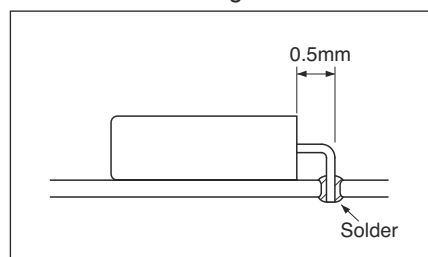

Figure 6

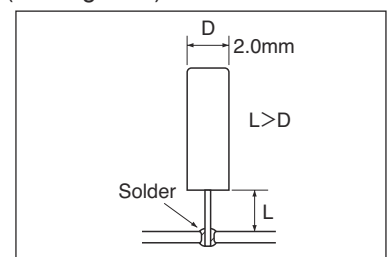

Figure 7

Soldering directly to the case will reduce the degree of vacuum and may result in deterioration of the characteristics and may break the crystal chip.

Make the length from the case to the printed circuit board (L) longer than the case diameter (D) so that the lead wire will not be pulled in case the crystal unit falls over.

2. Precautions for mounting plastic molded products

- If the board is deformed such as bending after mounting on the board, peeling of the soldered part between the crystal resonator and the board, the crack in the plastic molding, destruction of the internal element, etc. may occur. Especially when dividing the board on which it is mounted, there is a possibility that a large stress may be applied at the time of division. Please consider board layout and cutting method to minimize stress on products.
- When the product is automatically mounted on the board, if a large impact is applied to the crystal resonator, there is a possibility that characteristics may change / deteriorate or the product may be broken. When mounting automatically, please set conditions considering the shock to the crystal unit. Also, please conduct the mounting test beforehand and confirm that there is no influence on the characteristics to the crystal resonator.

Quartz Crystal Unit Handling Precautions

3. Precautions for mounting ceramic package products

- If the board is deformed such as bending after mounting on the board, peeling of the soldered part between the crystal resonator and the board, the crack in the ceramic package, destruction of the internal element, etc. may occur. Especially when dividing the board on which it is mounted, there is a possibility that a large stress may be applied at the time of division. Please consider board layout and cutting method to minimize stress on products.
- When the product is automatically mounted on the board, if a large impact is applied to the crystal resonator, there is a possibility that characteristics may change / deteriorate or the product may be broken. When mounting automatically, please set conditions considering the shock to the crystal unit. Also, please conduct the mounting test beforehand and confirm that there is no influence on the characteristics to the crystal resonator.
- The cracks may be occurred in the soldered part by repeating the harsh temperature change for a long time when mounting the product on a board having a expansion coefficient different from that of the ceramics used in the crystal package. When using under such circumstances, please conduct test beforehand at your company and confirm that there is no influence on the crystal unit.
- Ceramic packages are small and thin products. So when you repair the rework after mounting, please give due consideration to the selection and handling of the tools to be used.

4. SOLDERING

- Cylinder

The soldering position has to be at the lead wire more than 1.0mm away from the glass seal.

A long time for heating at high temperature may result in deterioration of the characteristics and may break the crystal unit.

If crystal unit is unavoidably heated, heat the lead part at 300°C or lower for 5 seconds or less and please make sure to keep the case below 150°C.

- Ceramic package, Plastic mold, Oscillator

An example of the reflow temperature profile is shown as follows (see Figure 8).

Example of SMD product soldering conditions
(260°C peak: Lead-free products)

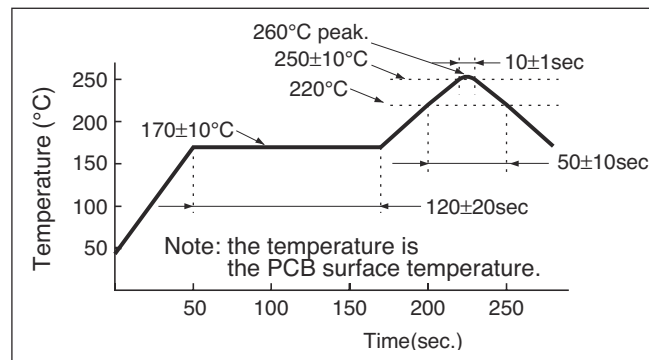

Figure 8

5. CLEANING

- Since a small, thin crystal chip is used for tuning fork crystal units and the frequency approximates that of an ultrasonic cleaner, the crystal chip may break easily. Therefore, DO NOT perform ultrasonic cleaning.

6. MECHANICAL SHOCK

- Quartz crystal units are designed to withstand a drop from 75cm onto a concrete at least 3 times. However, their crystal chips may break depending on the conditions when they are dropped. Ensure that the crystal unit functions normally before use if the crystal units have been dropped or subjected to an excessive mechanical shock.
- Unlike chip parts such as resistors, and capacitors, the SMD crystal unit has a crystal chip which is hermetically sealed inside. Therefore, check the influence of shock during automatic mounting or influence of deposition of case to the board by ultrasonic vibration before use.
- Avoid mounting crystal unit to the board with mechanical vibration source including ultrasonic vibration source. If the crystal unit is unavoidably mounted to the same board with mechanical vibration source, check that the crystal unit functions normally.

Quartz Crystal Unit Handling Precautions

7. Handling

- The crystal oscillator has an IC mounted on the backside of the package. Although it is resin-sealed, please do not directly touch the IC surface with tweezers, rigid tools and fixtures. If you scratch the IC, it may cause a malfunction, so be very careful.

8. Usage Condition

- Consider temperature and humidity in the product to be used, please use in the environment within the temperature range. When used in applications exposed to high humidity, malfunction due to dew condensation is a concern, so please take sufficient measures to prevent dew condensation.

9. Precautions for Oscillator

- Mounting
The oscillator has polarity, it may cause malfunctions or destruction. if mounting by the opposite direction.
- About the input terminals
Please follow the specifications of each product when use the input terminal.
- Board wiring
Power supply line / Ground pattern line should use a thick pattern to reduce the impedance.
Signal line should uses a thick pattern to reduce the impedance. It should be short for the distance to the connected IC.
For avoid noise effect, please make sure there is no pattern under crystal unit.
- Noise
If excessive external noise is applied to the terminals, the issue such as latch-up phenomenon and electrostatic breakdown may be happened.
- Heat stress
There is a risk of degradation of the crystal unit / IC due to a sudden temperature change. It should use under the specification.
- Power supply time
For avoid malfunction, it should be careful power-on time.

10. Precautions for handling reels

- Crystal products are degraded in characteristics when exposed for long periods under high or low temperature environments. Then, it should store at normal temperature and normal humidity.
Avoid storing for a long time and mount the crystal units immediately after unpacked.

Normal temperature / humidity conditions: +15 to 35°C / 25 to 85%RH

- When delivered with tape reel, the tape reel may deform if large impact is applied.

Oscillation Circuit Design Precautions

1. DRIVE LEVEL (DL)

- The drive level of a crystal unit is shown by the level of the operating power or the current consumption (see Figures 9, 10, and 11).

Operating the crystal unit at an excessive power level will result in the degradation of its characteristics, which may cause frequency instability or physical failure of the crystal chip.

Design your circuit within absolute maximum drive level.

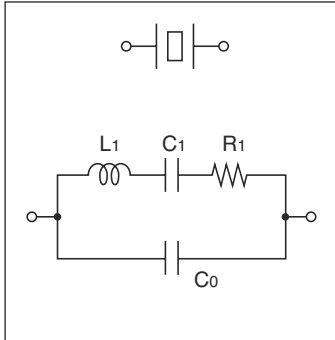

Figure 9

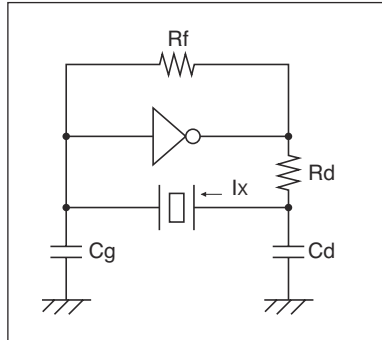

Figure 10

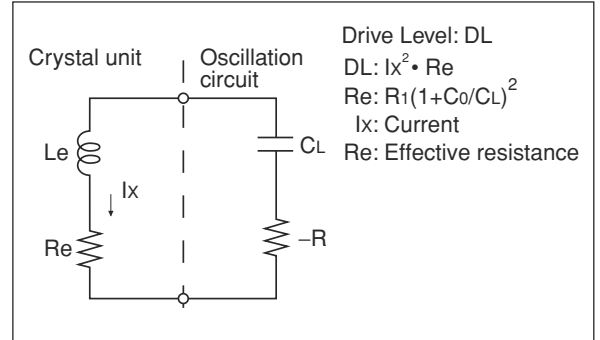

Figure 11

Drive Level: DL
 DL: $I_x^2 \cdot R_e$
 $R_e: R_1(1+C_0/C_L)^2$
 I_x : Current
 R_e : Effective resistance

2. OSCILLATION FREQUENCY AND LOAD CAPACITANCE (C_L)

- The load capacitance (C_L) is a parameter for determining the frequency of the oscillation circuit. The C_L is represented by an effective equivalent capacitance that is loaded from the oscillation circuit to both ends of the crystal unit (see Figure 12).

The oscillation frequency varies depending upon the load capacitance of the oscillation circuit. In order to obtain the desirable frequency accuracy, matching between the load capacitances of the oscillation circuit and the crystal unit is required. For the use of the crystal unit, match the load capacitances of the oscillation circuit with the load capacitances of the crystal unit.

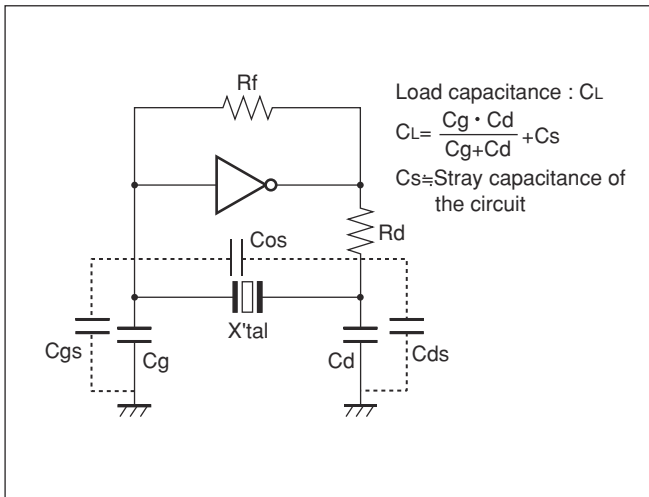

Figure 12

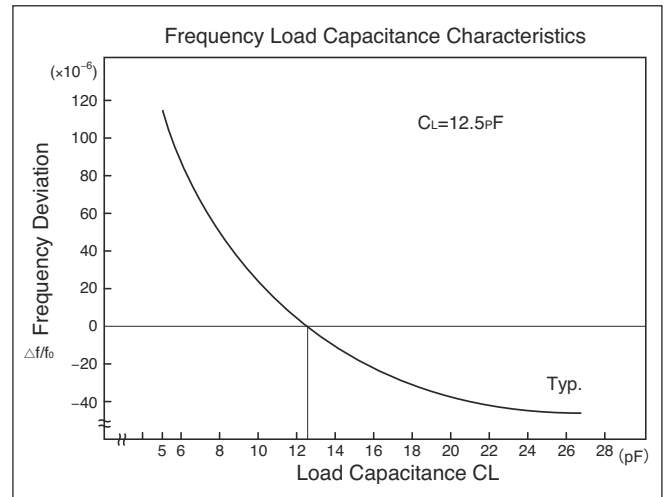

Figure 13

Oscillation Circuit Design Precautions

3. OSCILLATION ALLOWANCE

To ensure stable oscillation, the negative resistance of the circuit should be significantly larger than the equivalent series resistance (the oscillation allowance is large). Ensure that the oscillation allowance is at least five times as large as the equivalent series resistance.

Oscillation Allowance Evaluation Method

Add resistor “Rx” to the crystal unit in series and ensure that the oscillation starts or stops. The approximate negative resistance of the circuit is the value obtained by adding the effective resistance “Re” to the maximum resistance “Rx” when the oscillation starts or stops after gradually making Rx value larger.

Negative resistance $-R_l = R_x + R_e$

$-R_l$ is a value at least five times as large as the maximum equivalent series resistance (R_1 max.) of the crystal unit.

* R_e is the effective resistance value during oscillation.

$$R_e = R_1 \left(1 + \frac{C_0}{C_L}\right)^2$$

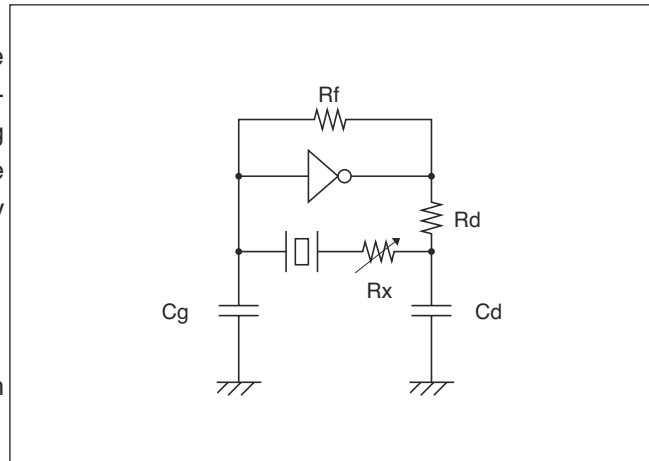
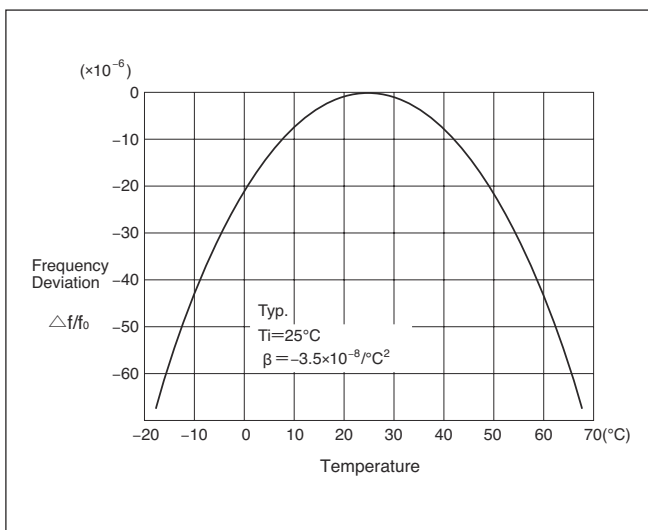

Figure 14

FREQUENCY-TEMPERATURE CURVE



Frequency Temperature Characteristics

Frequency temperature characteristics of tuning fork crystals is shown by negative quadratic curve which has a peak at 25°C as per left graph.

Please make sure to consider the temperature range and frequency accuracy you need since magnitude of frequency variation becomes larger and larger as the temperature range becomes wider.

[Approximation formula of frequency temperature characteristics]

$$f_{\text{tem}} = B (T - T_i)^2$$

β : Parabolic coefficient

T : Given temperature

T_i : Turnover temperature

LEAD TYPE PRODUCTS

After products are inserted in polyethylene bags, the bags are placed in boxes for shipping.

Product name	Quantity per lot	Quantity per bag	Quantity per box
VT-200-F / VT-200-FL	10,000 pcs	500 pcs	20 bags

SMD PRODUCTS

Product name	Quantity per reel
SSP-T7-F / SSP-T7-FL SC-32S / SC-32A / SC-32P / SC-32L / SC-20S / SC-20A / SC-20P / SH-32R / SN-20S	3,000 pcs
SC-16S / SC-12S	5,000 pcs
SC-20T	6,000 pcs

TAPE AND REEL CONFIGURATION

• Reel configuration

Product name	Reel inner width	Reel outer width	Product name	Reel inner width	Reel outer width
SSP-T7-F / SSP-T7-FL	17.0mm	19.4mm	SC-32S / SC-32A / SC-32P / SC-32L / SH-32R	13.0mm	15.4mm
SC-20S / SC-20P / SC-20T / SC-20A / SC-16S / SC-12S / SN-20S	9.0mm	11.4mm			

Packing

• Emboss tape configuration

Unit: mm

<p>Product name SSP-T7-F / SSP-T7-FL</p>	<p>Product name SC-32S / SC-32A / SC-32P / SC-32L / SH-32R</p>
<p>Product name SC-20S / SC-20A / SC-20P / SC-20T / SN-20S</p>	<p>Product name SC-16S</p>
<p>Product name SC-12S</p>	

• Precautions for handling reels

- (1) Store at normal temperature and normal humidity (refer to standard conditions of JIS Z-8703 laboratory). Avoid storing for a long time and mount the crystal units immediately after unpacked.
[Normal temperature: +15 to 35°C Normal humidity: 25 to 85%RH]
- (2) Handle outside boxes and reels with care.
Tapes and reels may be deformed by external pressure.

Seiko Instruments Inc.
Electronic Components Sales Head Office
1-8, Nakase, Mihamaku, Chiba-shi, Chiba 261-8507, Japan
Telephone:+81-43-211-1207 Facsimile:+81-43-211-8030
E-mail:component@sii.co.jp

<Manufacture>
SII Crystal Technology Inc.
1110, Hirai-cho, Tochigi-shi, Tochigi 328-0054, Japan



Asia

Seiko Instruments Trading (H.K.) Ltd.
4-5/F, Wyler Centre 2, 200 Tai Lin Pai Road,
Kwai Chung, N.T., Hong Kong
Tel: +852 2494-5111
Fax: +852 2424-0901
Email:sales@sih.com.hk
<http://www.sih.com.hk>

Seiko Instruments (Shanghai) Inc.
Room 2701, Shanghai Plaza,
No.138, Mid Huaihai Rd.,
Shanghai 200021, China
Telephone: +86-21-6375-6611
Facsimile: +86-21-6375-6727

Seiko Instruments (Shanghai) Inc.
Shenzhen Branch
Rm 2215, Shun Hing Square,
Di Wang Commerical Center,
5002 Shen Nan Dong Rd, Shenzhen,
China (518001)
Telephone: +86-755-8246-2680
Facsimile: +86-755-8246-5140

Seiko Instruments Taiwan Inc.
2F, No.143, Changchun Rd.,
Zhongshan Dist., Taipei 104, Taiwan
Telephone: +886-2-2563-5001
Facsimile: +886-2-2563-5580
Email:public@sii.co.jp
<http://www.sii.com.tw>

Europe

Seiko Instruments GmbH
Siemensstrasse 9
D-63263 Neu Isenburg, Germany
Telephone: +49-6102-297-0
Facsimile: +49-6102-297-222
Email:info@seiko-instruments.de
<http://www.seiko-instruments.de>

North/Central/South America

Seiko Instruments U.S.A., Inc.
21221 S. Western Ave., Suite 250,
Torrance, CA 90501, U.S.A.
Telephone: +1-310-517-7802
Facsimile: +1-310-878-0345
Email:info@seikoinstruments.com
<http://www.seikoinstruments.com>

Contact us

(Specifications are subject to change without notice.)

Released in February 2022