

NOTES:

1. MATERIALS AND FINISHES:

BODY, INNER BODY,
 HEX NUT & LOCKWASHER - BRASS, TIN-NICKEL ALLOY PLATING
 CONTACT - BeCu, GOLD PLATING
 BULLET CONTACT - BRASS, GOLD PLATING
 INSULATOR & INSULATOR DISC - PTFE, NATURAL
 FERRULE - COPPER, TIN-NICKEL ALLOY PLATING
 GASKET & O-RING - SILICONE RUBBER, RED
 HEAT SHRINK TUBING - CROSSLINKED POLYOLEFIN, BLACK

2. ELECTRICAL:

A. IMPEDANCE: 50 OHM
 B. FREQUENCY RANGE: DC - 6 GHz
 C. DIELECTRIC WITHSTANDING VOLTAGE: 1000 VRMS, MIN.

3. MECHANICAL:

A. DURABILITY: 500 CYCLES MIN.
 B. TEMPERATURE RANGE: -55°C TO +85°C
 C. SALT SPRAY PER MIL-STD-202, METHOD 101, WITH FOLLOWING PARAMETERS:
 1) TEST CONDITION B
 2) 5% SALT SOLUTION
 3) CYCLE REPEATED TO 720 HOURS

4. PACKAGING:

A. QUANTITY: SINGLE PACK
 B. MARKING: PACKAGING TO BE MARKED
 "AMPHENOL RF, 82-6512-EE AND DATE CODE"

5. CABLE ASSEMBLY INSTRUCTIONS:

- A. TRIM CABLE AS SHOWN.
- B. SLIDE HEAT SHRINK TUBING, FERRULE AND INSULATOR DISC ONTO CABLE.
- C. SOLDER CABLE CENTER CONDUCTOR TO BULLET CONTACT.
- D. INSERT CABLE WITH FOIL ENTERING CONNECTOR AND BRAID OVER KNURL.
- E. CRIMP FERRULE OVER BRAID WITH 0.429" HEX DIE.
- F. APPLY HEAT SHRINK TUBING OVER FERRULE.
- G. HEAT SHRINK TUBING SHOULD FULLY (360 DEG) COVER THE BUMP ON BODY AND END WITHIN AREA "A"

6. RECOMMENDED TORQUE APPLIED ON HEX NUT : 7-10 IN-LBS.

7. SHOW CABLE ENTRY DIMENSIONS.

REVISIONS				
REV	DESCRIPTION	DATE	ECN	BY
A	RELEASE TO MFG.	16-SEP-22	16394	SG
B	NO CHANGES TO THIS SHEET	28-OCT-22	16448	SH

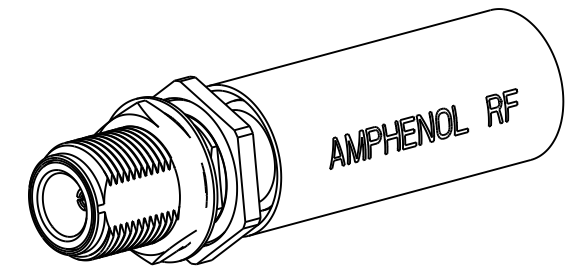

SCALE 1.000

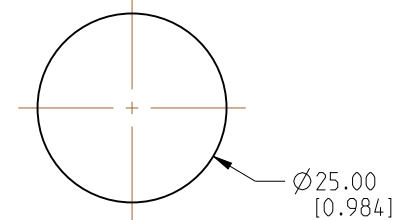

MIN PASS THRU DIAMETER

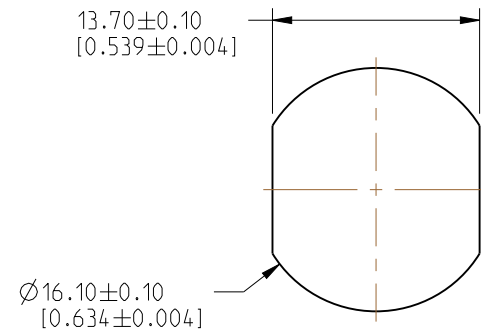

RECOMMENDED MOUNTING HOLE DIMENSIONS

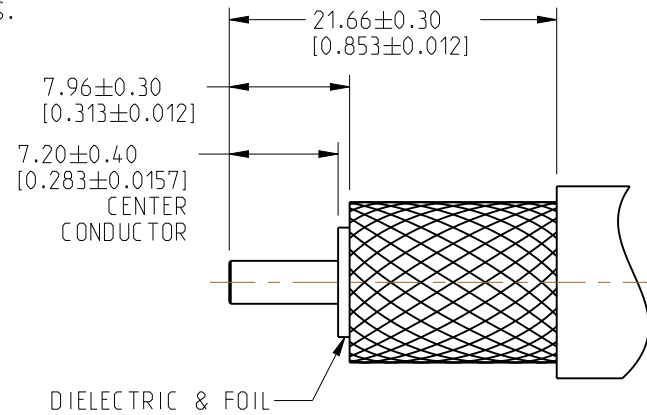

RECOMMENDED CABLE STRIPPING DIMENSIONS

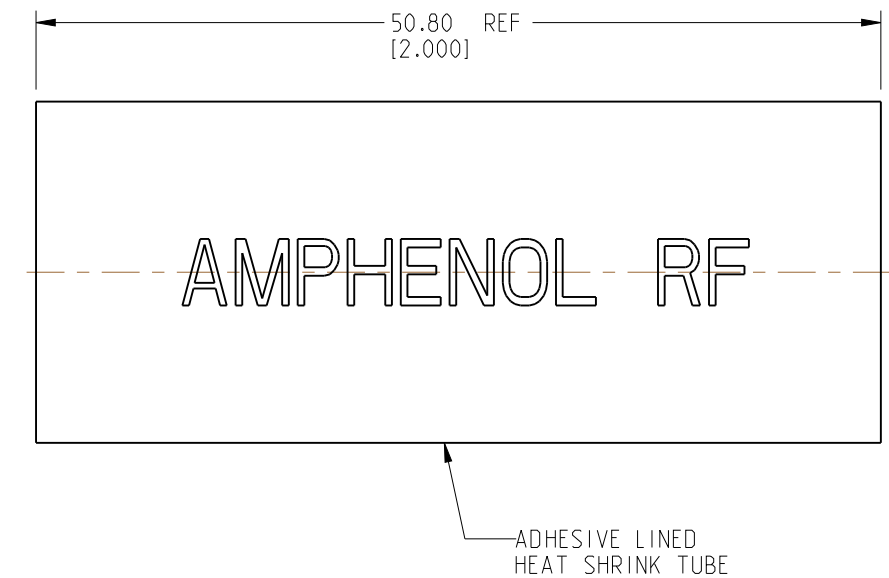
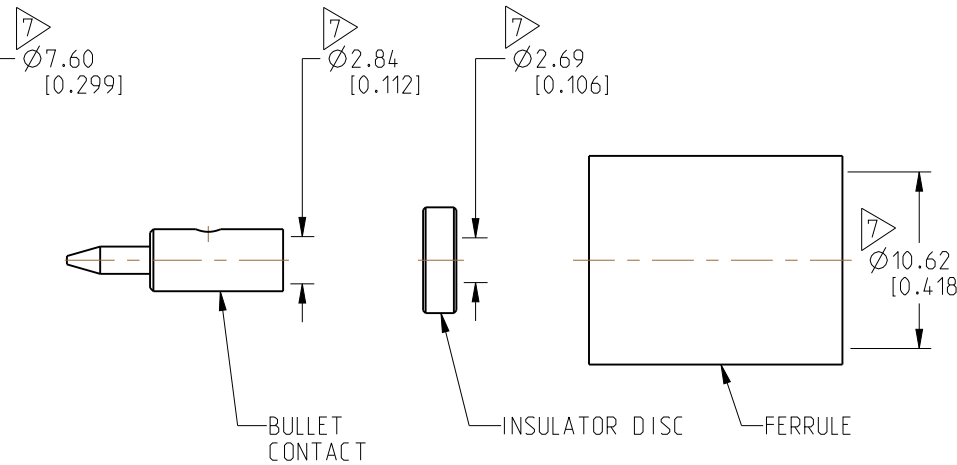
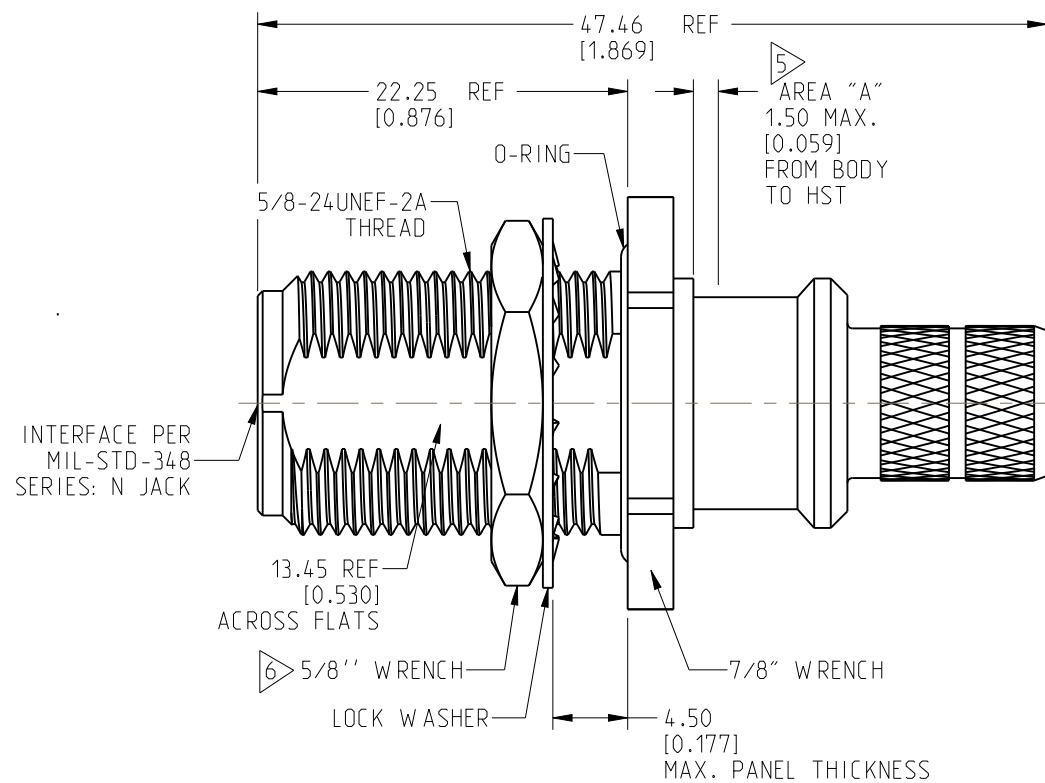

CUSTOMER OUTLINE DRAWING

ALL OTHER SHEETS ARE FOR INTERNAL USE ONLY

NOTICE: These drawings, specifications, or other data (1) are, and remain the property of Amphenol corp. (2) must be returned upon request; and (3) are confidential and not to be disclosed to any person other than those to whom they are given by Amphenol Corp. The furnishing of these drawings, specifications, or other data by Amphenol Corp., or to any other person to anyone for any purpose is not to be regarded by implication or otherwise in any manner licensing, granting rights to permitting such holder or any other person to manufacture, use or sell any product, process or design, patented or otherwise, that may in any way be related to or disclosed by said drawings, specifications, or other data.

UNLESS OTHERWISE SPECIFIED DIMENSIONS ARE METRIC (INCHES) AND TOLERANCES ARE:
 <0.5mm = ±0.05mm [-0.020 = ±0.002]
 0.5 - 6mm = ±0.1mm [-0.020 - 0.236 = ±0.004]
 >6.00 - 30mm = ±0.2mm [-0.236 - 1.181 = ±0.008]
 >30.00 - 120mm = ±0.3mm [-1.181 - 4.725 = ±0.012]

MATERIAL: SEE NOTES
 ENGR.1: SIVA
 ENGR.2: M.ZHANG
 DATE: 27-JUN-22

TITLE: N STR BHD JACK IP 67 FOR LMR 400 CABLE EXTREME EXPOSURE
 SHEET NO. 2 OF 2
 SCALE: 2.2:1.0

SIZE: B	DRAWING NO. 82-6512-EE	REV: B
	ITEM NO. 82-6512-EE	
	PART NO. 82-6512-EE	

THIRD ANGLE PROJ.

REFERENCE: 82-6512
 EAR#: 11374

ANGLES = ±1°