

PART NUMBER	REV	FIRST USED
680831-1	B	122500-1
680831-2	B	565435-5
680831-3	B	354500-1

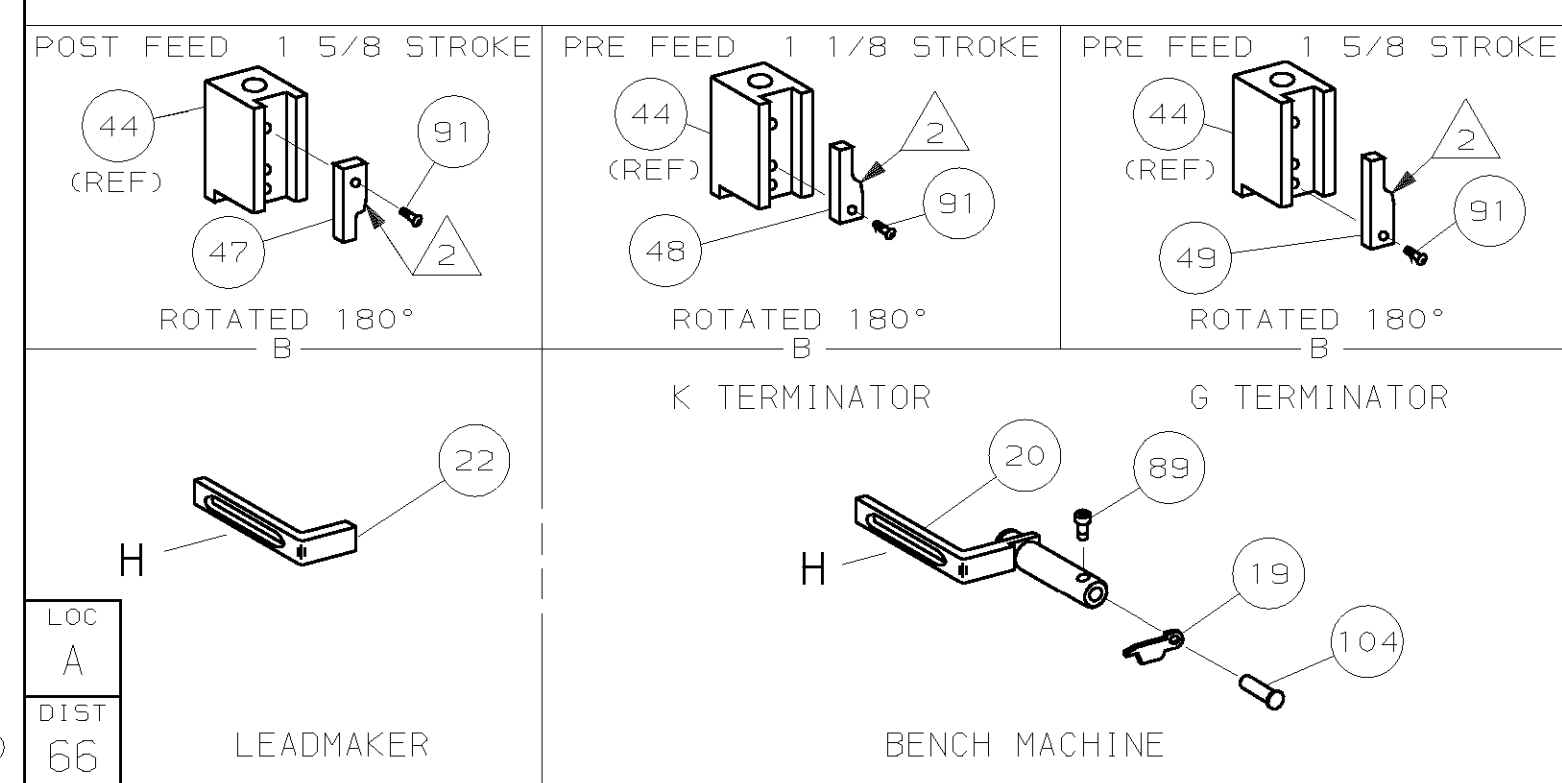
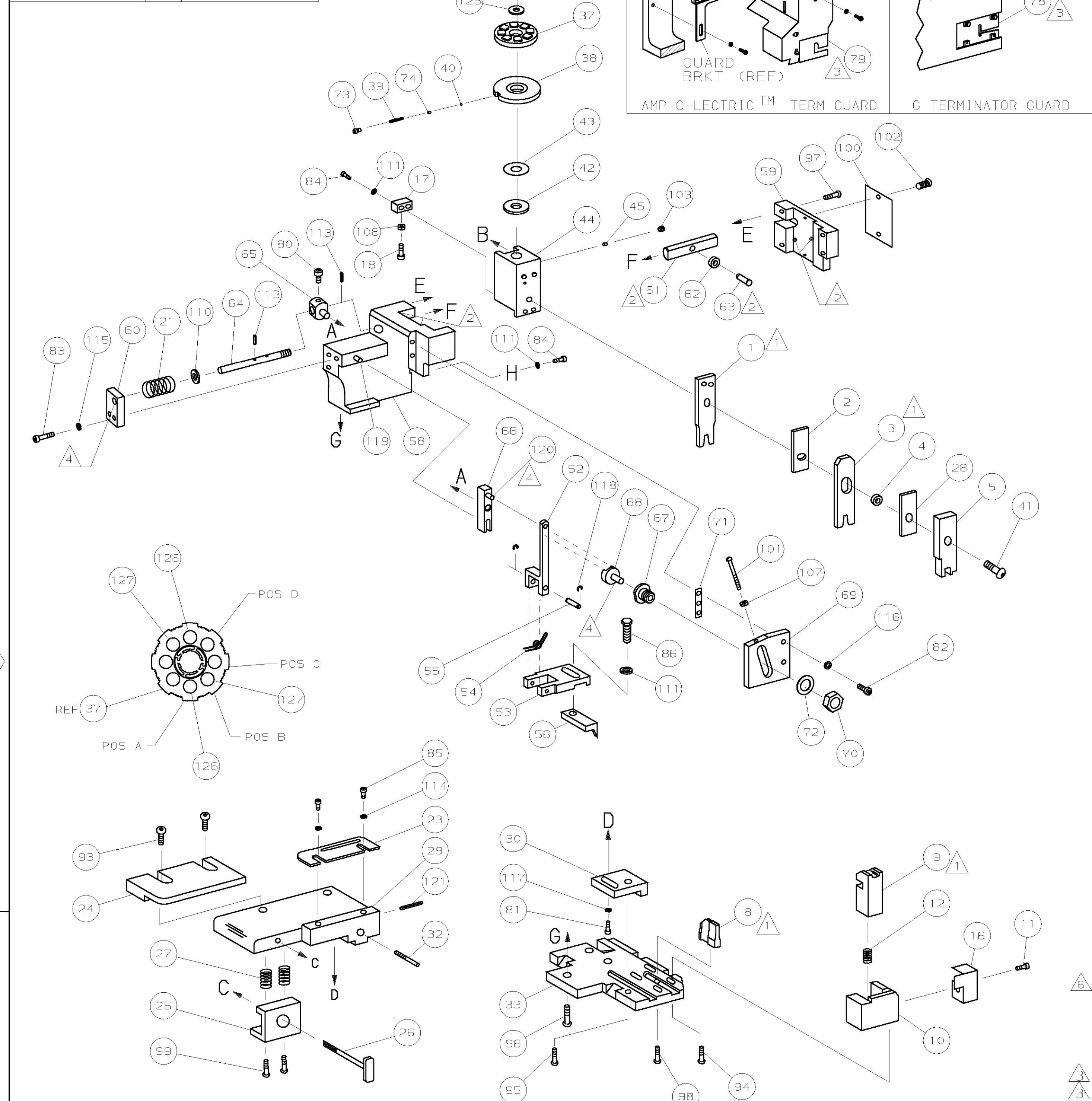

LOC A
DIST 66
AMP 1756 REV 3-92
16-SEP-99 10:07:33 amp18246

- 1 RECOMMENDED SPARE PARTS.
- 2 GREASE LIGHTLY.
- 3 GUARD MUST BE IN PLACE WHEN OPERATING APPLICATOR IN A BENCH MACHINE.
- 4 LUBRICATE DAILY USING NO. 20 MACHINE OIL.
- 5. ITEMS WITH QTY OF REF SPECIFIED (EXCEPT ITEMS 78 AND 79) ARE USED ON ITEM 46.
- 6 CUT TO LENGTH AT ASSY.

TERMINAL NAME: TAB CONTACT FOR AMPSLIM			
353069-1 CRIMP DATA (AMP TERMINAL)			
PAD LTR	CRIMP HEIGHT	WIRE SIZE	
A	.018 ±.002 [0.46 ±0.05mm]	28	
B	.017 ±.002 [0.43 ±0.05mm]	30	
C	NOT	USED	
D	NOT	USED	
CRIMP	SIZE	TYPE	RANGE
WIRE	.033 [0.84mm]	F	28-30
INSUL	.037 [0.94mm]	F	φ.020-φ.035

WIRE STRIP LENGTH	TERM APPL SPEC	FEED	APPL INSTRUCTION	SET UP GAGE	LAYOUT
.063-.094	114-5225	.315	408-8040	458637-1	L2246

QTY	REF	REF	REF	U/M	DWG SIZE	PART NO	DESCRIPTION	ITEM NO
129								129
128								128
2	2	2	-	C		3-354779-4	PIN, WIRE DISC (.3160)B	127
2	2	2	-	C		3-354779-2	PIN, WIRE DISC (.3150)A	126
1	1	1	-	A		986950-1	WASHER, FLAT PRECISION	125
1	1	1	-	A		217238-1	GENERAL INSTRUCTION PACKAGE	124
1	1	1	-	-		4088040	SF APPL INST 408-8040	123
1	1	1	-	A		4-21028-0	PIN, SLT SPR (φ.093x.75)ST GDE PL	122
REF	REF	REF	-	A		1-21030-1	PIN, DOWEL (φ.187x.50)LEVER	120
REF	REF	REF	-	A		1-21030-6	PIN, DOWEL (φ.187x1.25)HOUSING	119
REF	REF	REF	-	A		21045-3	RING, RET "C" (φ.187)FD FING PIN	118
1	1	1	-	A		21024-5	WASHER, LOCK (#10)ADJ BLK	117
REF	REF	REF	-	A		21024-5	WASHER, LOCK (#10)ADJ PLATE	116
REF	REF	REF	-	A		21024-5	WASHER, LOCK (#10)FEED GDE ROD	115
2	2	2	-	A		21024-2	WASHER, LOCK (#4)FRONT STP GUIDE	114
REF	REF	REF	-	A		5-21028-1	PIN, SLT SPR (φ.125x.50)ADJ ROD	113
								112
4	4	4	-	A		21024-4	WASHER, LOCK (#8)STRIPPER	111
REF	REF	REF	-	A		21899-4	WASHER, FLAT (φ5/16)SCREW ADJ	110
								109
1	1	1	-	A		21018-5	NUT, HEX (NO. 6)HOLDDOWN	108
REF	REF	REF	-	A		21068-5	NUT, HEX (6-32)FEED ADJ	107
								106
								105
1	1	-	-	A		992031-1	PIN, CLEVIS	104
1	1	1	-	A		21009-2	SCR, SKT SET (1/4-20x.25 LW)RAM	103
2	2	2	-	A		21017-2	SCR, DRIVE (#2x.19)ID PLATE	102
REF	REF	REF	-	A		6-23715-5	SCR, PAN HD (6-32x1.50)FEED ADJ	101
1	1	1	-	B		461264-1	PLATE, IDENTIFICATION	100
2	2	2	-	A		3-21002-0	SCR, BHC (10-32x.88)DRAG	99
1	1	1	-	A		22733-8	SCR, BHC (8-32x.38 LW)ANVIL	98
REF	REF	REF	-	A		2-21002-9	SCR, BHC (10-32x.75)CAP	97
REF	REF	REF	-	A		2-22733-8	SCR, BHC (1/4-20x.62)HOUSING	96
REF	REF	REF	-	A		2-21002-7	SCR, BHC (10-32x.50)5G ADJ BLOCK	95
2	2	2	-	A		2-21002-2	SCR, BHC (8-32x.50)TERM H DWN	94
2	2	2	-	A		2-21002-2	SCR, BHC (8-32x)R STP GDE	93
								92
1	1	1	-	A		1-21002-7	SCR, BHC (6-32x.38)CAM	91
								90
1	1	-	-	A		7-21000-9	SCR, SHC (4-40x.19)STRIPPER	89
								88
								87
1	1	1	-	A		2-22603-0	SCR, HEX HD (8-32x.31)FEED FINGER	86
2	2	2	-	A		1-21000-3	SCR, SHC (4-40x.25)F ST GUIDE	85
3	3	3	-	A		2-21000-7	SCR, SHC (8-32x.50)STRIPPER	84
REF	REF	REF	-	A		3-21000-7	SCR, SHC (10-32x.75)FEED ROD GD	83
REF	REF	REF	-	A		3-21000-6	SCR, SHC (10-32x.62)ADJ BLK	82
1	1	1	-	A		3-21000-4	SCR, SHC (10-32x.38)5G ADJ BL	81
REF	REF	REF	-	A		3-21000-4	SCR, SHC (10-32x.38)PIVOT BLK	80
-	REF	-	-	B		455749-1	GUARD, WINDOW	79
REF	-	-	-	B		679532-1	INSERT, GUARD	78
								77
								76
								75
1	1	1	-	A		690603-1	SPRING, ASSIST	74
1	1	1	-	A		23030-1	SCR, SHC (6-32x.25 SL)INS DISC	73
REF	REF	REF	-	A		458109-1	WASHER, SPECIAL	72
REF	REF	REF	-	A		690517-1	SPACER	71
-3	-2	-1	U/M	DWG SIZE		PART NO	DESCRIPTION	ITEM NO
QTY REOD PER ASSY PARTS LIST								

QTY	REF	REF	REF	U/M	DWG SIZE	PART NO	DESCRIPTION	ITEM NO
								70
								69
								68
								67
								66
								65
								64
								63
								62
								61
								60
								59
								58
								57
								56
								55
								54
								53
								52
								51
								50
								49
								48
								47
								46
								45
								44
								43
								42
								41
								40
								39
								38
								37
								36
								35
								34
								33
								32
								31
								30
								29
								28
								27
								26
								25
								24
								23
								22
								21
								20
								19
								18
								17
								16
								15
								14
								13
								12
								11
								10
								9
								8
								7
								6
								5
								4
								3
								2
								1
-3	-2	-1	U/M	DWG SIZE		PART NO	DESCRIPTION	ITEM NO
QTY REOD PER ASSY PARTS LIST								

DIMENSIONS IN INCHES. DO NOT SCALE PRINT. TOLERANCES UNLESS OTHERWISE SPECIFIED:
 2 PLC DEC ±
 3 PLC DEC ±
 4 PLC DEC ±
 ANGLES ±
 SURF TEXTURE: ✓
 REMOVE BURRS, BREAK SHARP EDGES R.015 MAX

MATL - HT TR - FIN -
 DR M.HERR 27MAY99 APP T.ELBIN 27MAY99
 CHK 27MAY99 REL -
AMP AMP Incorporated Harrisburg, PA 17105-3608
 NAME SIDE FEED HDM APPLICATOR MACHINE REF MINI APPL
 SCALE - DWG NO 680831 SHEET 1 OF 1 REV B
 CASE CODE 00779 CUSTOMER AND ASSEMBLY DRAWING RESTRICTED TO

THIS DRAWING IS A CONTROLLED DOCUMENT.

RELEASING FOR PUBLICATION JUN 15, 1999 BY AMP INCORPORATED. ALL RIGHTS RESERVED.

150030
D
C
B
A