

Revision History**8Mb - 512k x 16bit SUPER LOW POWER CMOS SRAM**

Revision	Details	Date
Rev 1.0	Initial Release	Nov 2020

FEATURES

- Fast access time : 45/55ns
- Low power consumption:
 Operating current : 12mA /10mA(TYP.)
 Standby current : 2.5 μ A (TYP.)
- Single 2.7V ~ 3.6V power supply
- All inputs and outputs TTL compatible
- Fully static operation
- Tri-state output
- Data byte control : LB# (DQ0 ~ DQ7)
 UB# (DQ8 ~ DQ15)

- Data retention voltage : 1.5V (MIN.)
- Package : 44-pin 400mil TSOP II

GENERAL DESCRIPTION

The AS6C8016B is a 8,388,608-bit low power CMOS static random access memory organized as 524,288 words by 16 bits. It is fabricated using very high performance, high reliability CMOS technology. Its standby current is stable within the range of operating temperature.

The AS6C8016B is well designed for low power application, and particularly well suited for battery back-up nonvolatile memory application.

The AS6C8016B operates from a single power supply of 2.7V ~ 3.6V and all inputs and outputs are fully TTL compatible

PRODUCT FAMILY

Product Family	Operating Temperature	V _{CC} Range	Speed	Power Dissipation	
				Standby(I _{SB1} , TYP.)	Operating(I _{CC} , TYP.)
AS6C8016B-45ZIN	-40 ~ 85°C	2.7 ~ 3.6V	45ns	2.5 μ A	12mA
AS6C8016B-55ZIN	-40 ~ 85°C	2.7 ~ 3.6V	55ns	2.5 μ A	10mA

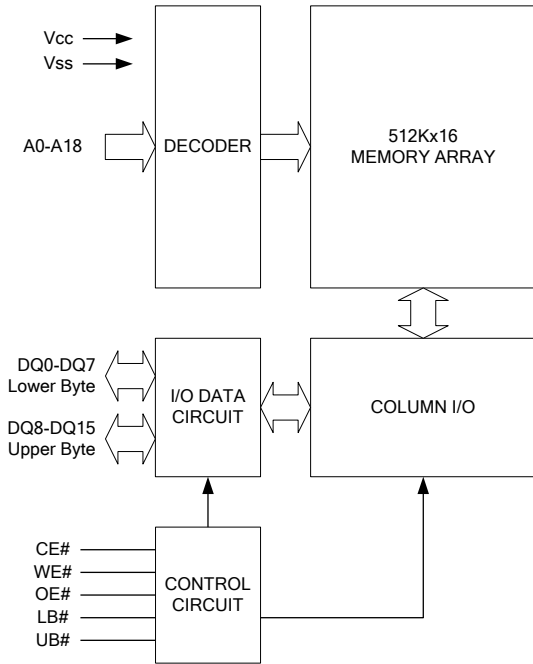
FUNCTIONAL BLOCK DIAGRAM

PIN DESCRIPTION

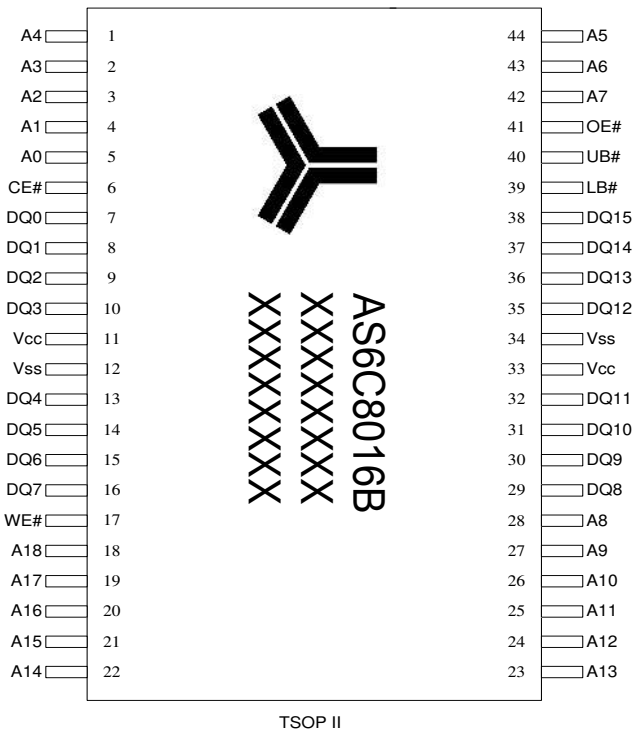
SYMBOL	DESCRIPTION
A0 - A18	Address Inputs
DQ0 – DQ15	Data Inputs/Outputs
CE#	Chip Enable Input
WE#	Write Enable Input
OE#	Output Enable Input
LB#	Lower Byte Control
UB#	Upper Byte Control
V _{CC}	Power Supply
V _{SS}	Ground



ABSOLUTE MAXIMUM RATINGS*

PARAMETER	SYMBOL	RATING	UNIT
Voltage on V _{CC} relative to V _{SS}	V _{T1}	-0.5 to 4.6	V
Voltage on any other pin relative to V _{SS}	V _{T2}	-0.5 to V _{CC} +0.5	V
Operating Temperature	T _A	-40 to 85	°C
Storage Temperature	T _{STG}	-65 to 150	°C
Power Dissipation	P _D	1	W
DC Output Current	I _{OUT}	50	mA

*Stresses greater than those listed under "Absolute Maximum Ratings" may cause permanent damage to the device. This is a stress rating only and functional operation of the device or any other conditions above those indicated in the operational sections of this specification is not implied. Exposure to the absolute maximum rating conditions for extended period may affect device reliability.

TRUTH TABLE

MODE	CE#	OE#	WE#	LB#	UB#	I/O OPERATION		SUPPLY CURRENT
						DQ0-DQ7	DQ8-DQ15	
Standby	H	X	X	X	X	High – Z	High – Z	I _{SB1}
	X	X	X	H	H	High – Z	High – Z	
Output Disable	L	H	H	L	X	High – Z	High – Z	I _{CC} , I _{CC1}
	L	H	H	X	L	High – Z	High – Z	
Read	L	L	H	L	H	D _{OUT}	High – Z	I _{CC} , I _{CC1}
	L	L	H	H	L	High – Z	D _{OUT}	
	L	L	H	L	L	D _{OUT}	D _{OUT}	
Write	L	X	L	L	H	D _{IN}	High – Z	I _{CC} , I _{CC1}
	L	X	L	H	L	High – Z	D _{IN}	
	L	X	L	L	L	D _{IN}	D _{IN}	

Note: H = V_{IH}, L = V_{IL}, X = Don't care.

DC ELECTRICAL CHARACTERISTICS

PARAMETER	SYMBOL	TEST CONDITION	MIN.	TYP. *4	MAX.	UNIT	
Supply Voltage	V_{CC}		2.7	3.0	3.6	V	
Input High Voltage	V_{IH}^{*1}		2.2	-	$V_{CC}+0.3$	V	
Input Low Voltage	V_{IL}^{*2}		- 0.2	-	0.6	V	
Input Leakage Current	I_{LI}	$V_{CC} \geq V_{IN} \geq V_{SS}$	- 1	-	1	μA	
Output Leakage Current	I_{LO}	$V_{CC} \geq V_{OUT} \geq V_{SS}$, Output Disabled	- 1	-	1	μA	
Output High Voltage	V_{OH}	$I_{OH} = -1mA$	2.2	2.7	-	V	
Output Low Voltage	V_{OL}	$I_{OL} = 2mA$	-	-	0.4	V	
Average Operating Power supply Current	I_{CC}	Cycle time = Min. $CE\# \leq 0.2V$ and $CE2 \geq V_{CC}-0.2V$ $I_{I/O} = 0mA$ Others at 0.2V or $V_{CC}-0.2V$	-45	-	12	20	mA
			-55	-	10	18	mA
	I_{CC1}	Cycle time = 1 μs $CE\# \leq 0.2V$ and $CE2 \geq V_{CC}-0.2V$ $I_{I/O} = 0mA$ Other pins at 0.2V or $V_{CC}-0.2V$	-	-	3	5	mA
Standby Power Supply Current	I_{SB1}	$CE\# \geq V_{CC}-0.2V$ or $CE2 \leq 0.2V$ Other pins at 0.2V	40°C	-	2.5	5	μA
		or $V_{CC}-0.2V$		-	2.5	20	μA

Notes:

- $V_{IH}(\max) = V_{CC} + 3.0V$ for pulse width less than 10ns.
- $V_{IL}(\min) = V_{SS} - 3.0V$ for pulse width less than 10ns.
- Over/Undershoot specifications are characterized, not 100% tested.
- Typical values are included for reference only and are not guaranteed or tested.
Typical values are measured at $V_{CC} = V_{CC}(TYP.)$ and $T_A = 25^\circ C$

CAPACITANCE ($T_A = 25^\circ C$, $f = 1.0MHz$)

PARAMETER	SYMBOL	MIN.	MAX	UNIT
Input Capacitance	C_{IN}	-	6	pF
Input/Output Capacitance	$C_{I/O}$	-	8	pF

Note : These parameters are guaranteed by device characterization, but not production tested.

AC TEST CONDITIONS

Input Pulse Levels	0.2V to $V_{CC} - 0.2V$
Input Rise and Fall Times	3ns
Input and Output Timing Reference Levels	1.5V
Output Load	$C_L = 30pF + 1TTL$, $I_{OH}/I_{OL} = -1mA/2mA$

AC ELECTRICAL CHARACTERISTICS

(1) READ CYCLE

PARAMETER	SYM.	AS6C8016B-45		AS6C8016B-55		UNIT
		MIN.	MAX.	MIN.	MAX.	
Read Cycle Time	t_{RC}	45	-	55	-	ns
Address Access Time	t_{AA}	-	45	-	55	ns
Chip Enable Access Time	t_{ACE}	-	45	-	55	ns
Output Enable Access Time	t_{OE}	-	25	-	30	ns
Chip Enable to Output in Low-Z	t_{CLZ}^*	10	-	10	-	ns
Output Enable to Output in Low-Z	t_{OLZ}^*	5	-	5	-	ns
Chip Disable to Output in High-Z	t_{CHZ}^*	-	15	-	20	ns
Output Disable to Output in High-Z	t_{OHZ}^*	-	15	-	20	ns
Output Hold from Address Change	t_{OH}	10	-	10	-	ns
LB#, UB# Access Time	t_{BA}	-	45	-	55	ns
LB#, UB# to High-Z Output	t_{BHZ}^*	-	20	-	25	ns
LB#, UB# to Low-Z Output	t_{BLZ}^*	10	-	10	-	ns

(2) WRITE CYCLE

PARAMETER	SYM.	AS6C8016B-45		AS6C8016B-55		UNIT
		MIN.	MAX.	MIN.	MAX.	
Write Cycle Time	t_{WC}	45	-	55	-	ns
Address Valid to End of Write	t_{AW}	40	-	50	-	ns
Chip Enable to End of Write	t_{CW}	40	-	50	-	ns
Address Set-up Time	t_{AS}	0	-	0	-	ns
Write Pulse Width	t_{WP}	35	-	45	-	ns
Write Recovery Time	t_{WR}	0	-	0	-	ns
Data to Write Time Overlap	t_{DW}	20	-	25	-	ns
Data Hold from End of Write Time	t_{DH}	0	-	0	-	ns
Output Active from End of Write	t_{OW}^*	5	-	5	-	ns
Write to Output in High-Z	t_{WHZ}^*	-	15	-	20	ns
LB#, UB# Valid to End of Write	t_{BW}	35	-	45	-	ns

*These parameters are guaranteed by device characterization, but not production tested.

TIMING WAVEFORMS

READ CYCLE 1 (Address Controlled) (1,2)

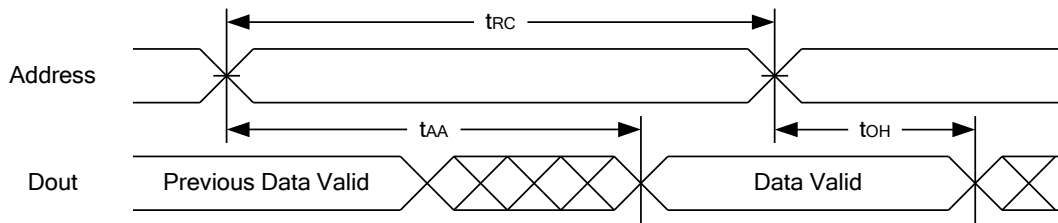

READ CYCLE 2 (CE# and OE# Controlled) (1,3,4,5)

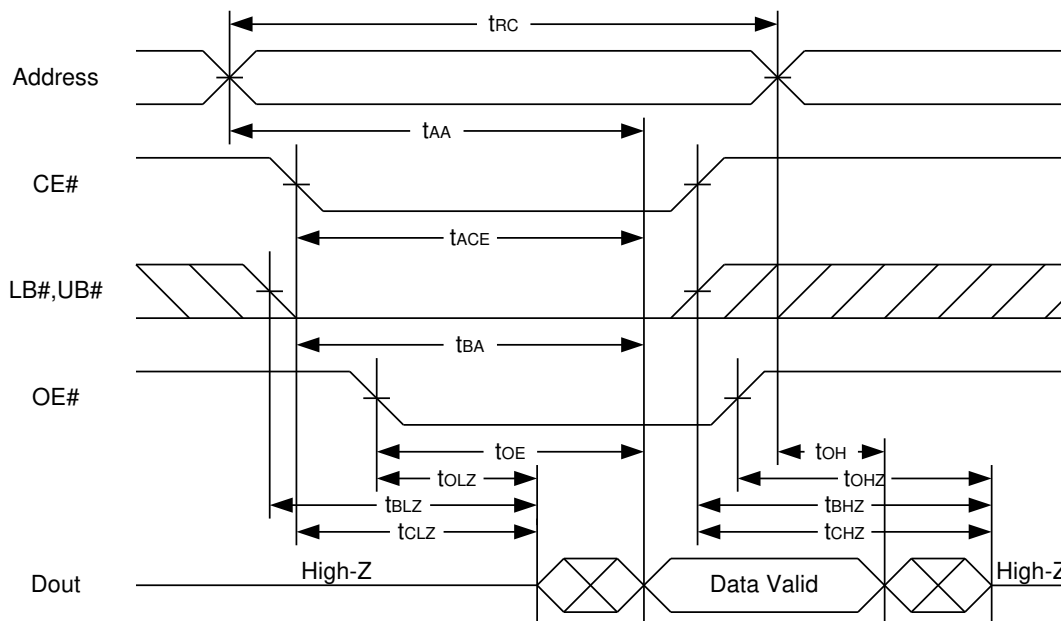

Notes :

1. WE# is high for read cycle.
2. Device is continuously selected OE# = low, CE# = low, LB# or UB# = low.
3. Address must be valid prior to or coincident with CE# = low, LB# or UB# = low transition; otherwise t_{AA} is the limiting parameter.
4. t_{CLZ} , t_{BLZ} , t_{OLZ} , t_{CHZ} , t_{BHZ} and t_{OHZ} are specified with $C_L = 5\text{pF}$. Transition is measured $\pm 500\text{mV}$ from steady state.
5. At any given temperature and voltage condition, t_{CHZ} is less than t_{CLZ} , t_{BHZ} is less than t_{BLZ} , t_{OHZ} is less than t_{OLZ} .

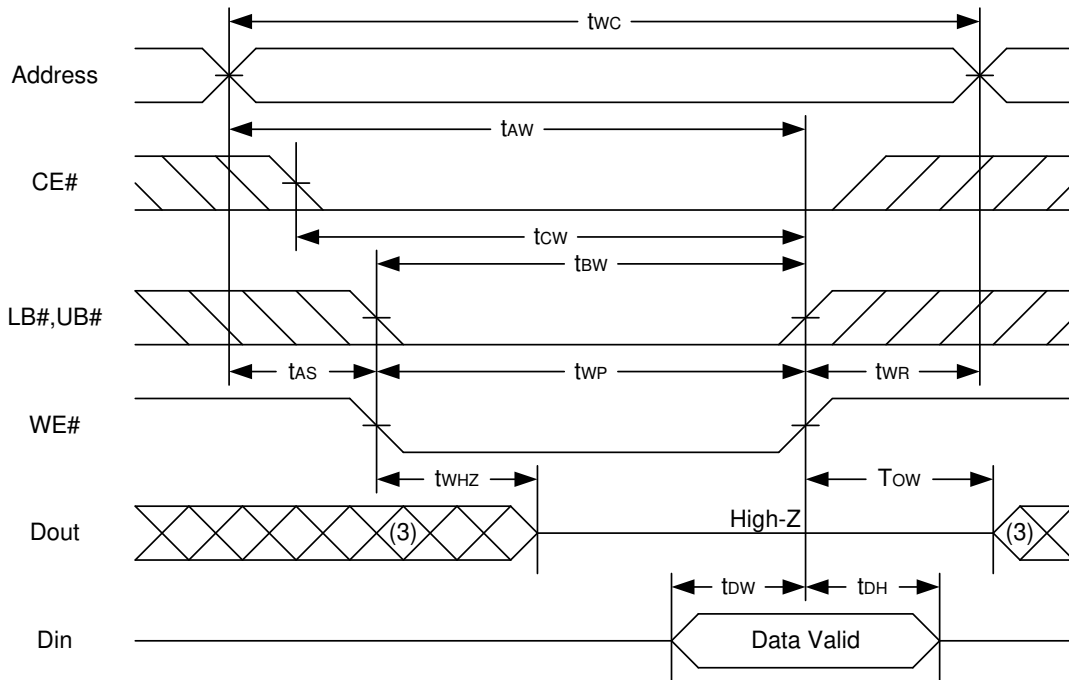
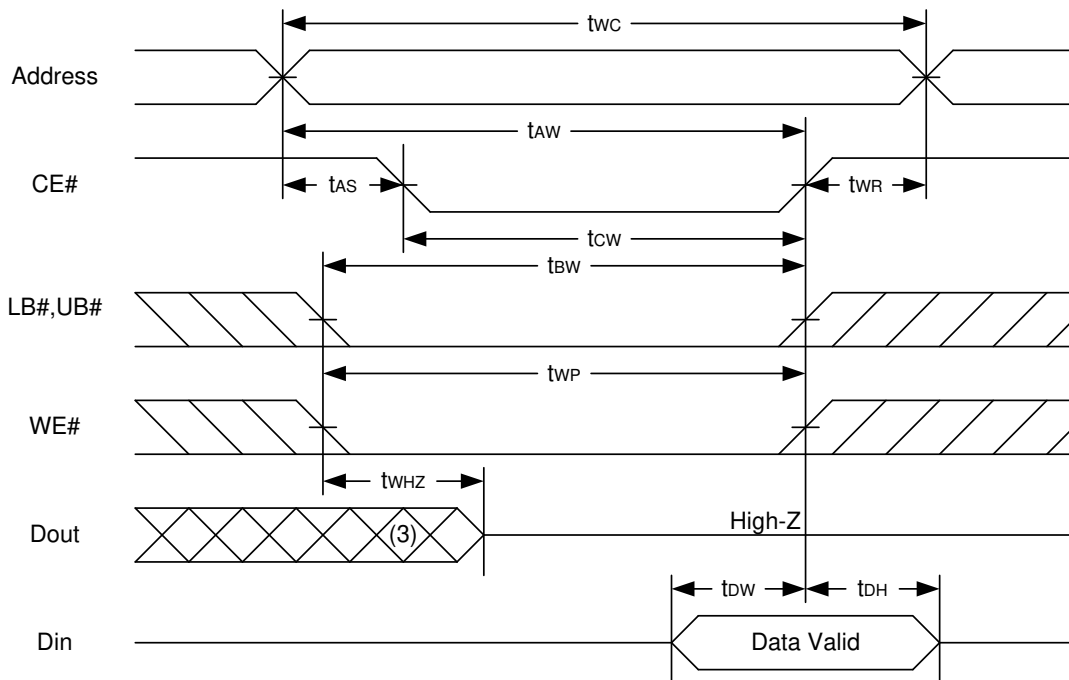
WRITE CYCLE 1 (WE# Controlled) (1,2,4,5)

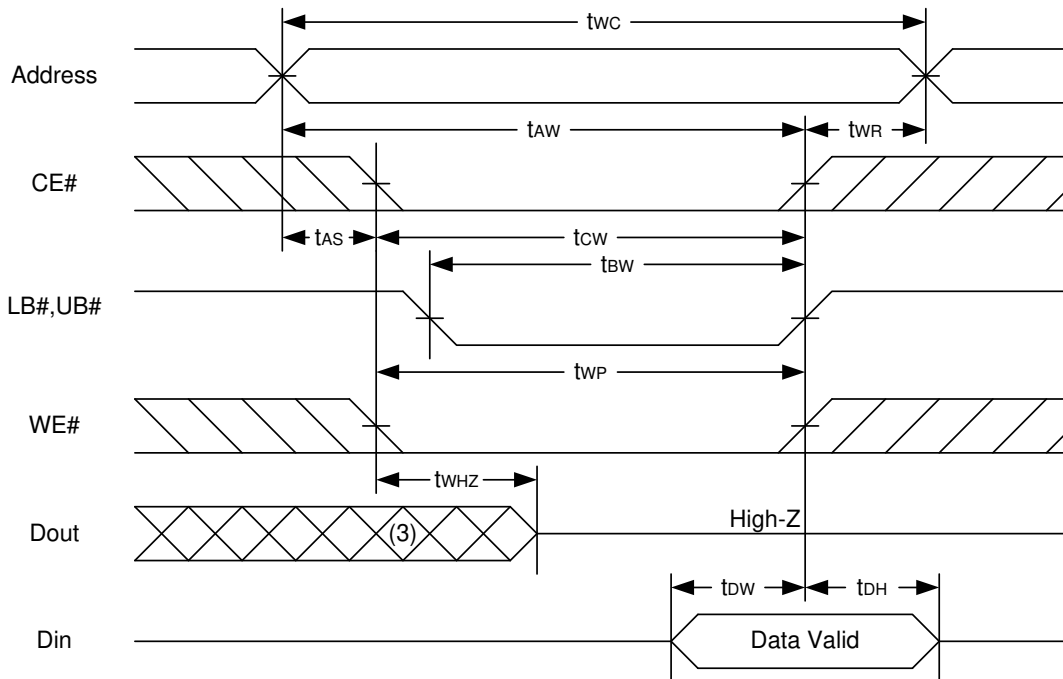
WRITE CYCLE 2 (CE# Controlled) (1,4,5)

WRITE CYCLE 3 (LB#,UB# Controlled) (1,4,5)

Notes :

1. A write occurs during the overlap of a low CE#, low WE#, LB# or UB# = low.
2. During a WE# controlled write cycle with OE# low, t_{WP} must be greater than $t_{WHZ} + t_{DW}$ to allow the drivers to turn off and data to be placed on the bus.
3. During this period, I/O pins are in the output state, and input signals must not be applied.
4. If the CE#, LB#, UB# low transition occurs simultaneously with or after WE# low transition, the outputs remain in a high impedance state.
5. t_{OW} and t_{WHZ} are specified with $C_L = 5pF$. Transition is measured $\pm 500mV$ from steady state.

DATA RETENTION CHARACTERISTICS

PARAMETER	SYMBOL	TEST CONDITION	MIN.	TYP.	MAX.	UNIT	
V _{CC} for Data Retention	V _{DR}	CE# ≥ V _{CC} - 0.2V	1.5	-	3.6	V	
Data Retention Current	I _{DR}	V _{CC} = 1.5V CE# ≥ V _{CC} - 0.2V	40°C	-	2	5	μA
		Other pins at 0.2V or V _{CC} -0.2V		-	2	20	μA
Chip Disable to Data Retention Time	t _{CDR}	See Data Retention Waveforms (below)	0	-	-	ns	
Recovery Time	t _R		t _{RC} *	-	-	ns	

t_{RC}* = Read Cycle Time

DATA RETENTION WAVEFORM

Low V_{CC} Data Retention Waveform (1) (CE# controlled)

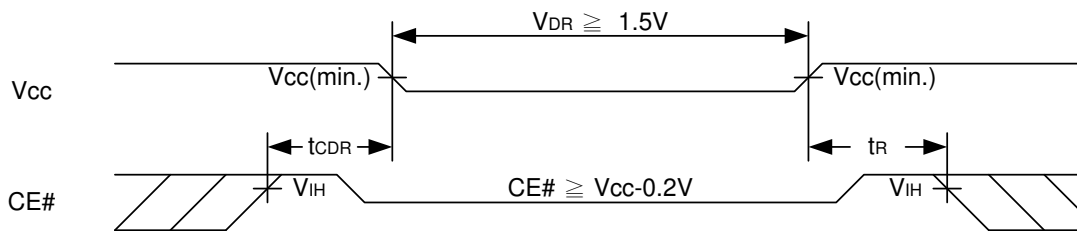

Low V_{CC} Data Retention Waveform (2) (LB#, UB# controlled)

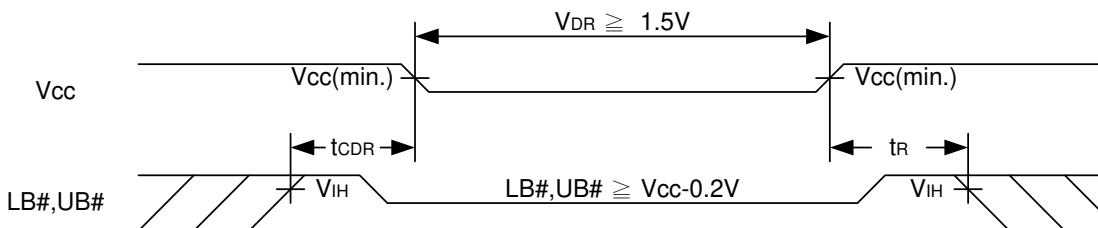

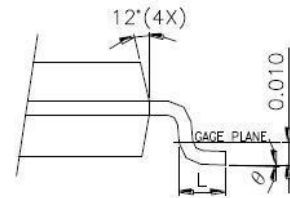
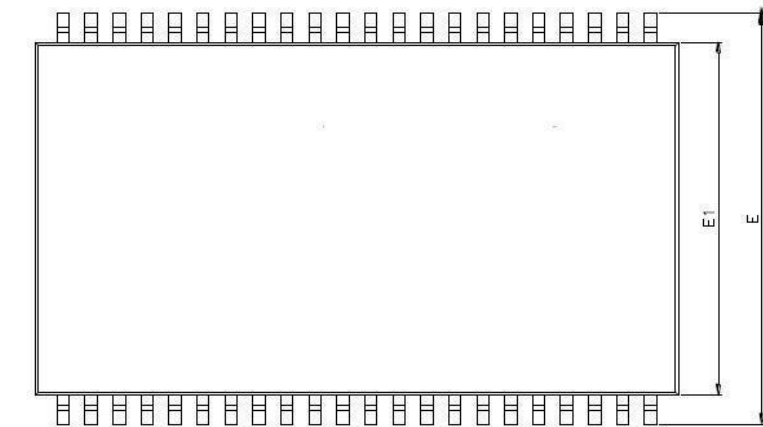
PACKAGE OUTLINE DIMENSION
44-pin 400mil TSOP II Package Outline Dimension

DETAIL B

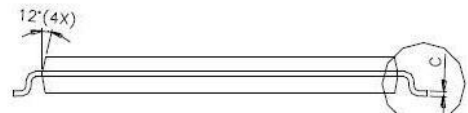
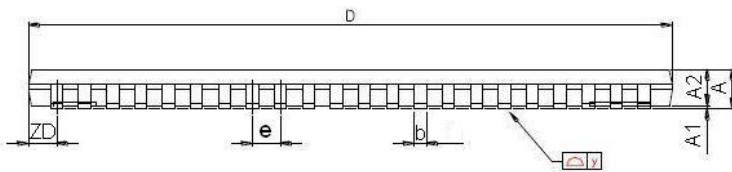

DETAIL B

SYMBOLS	DIMENSIONS IN MILLMETERS			DIMENSIONS IN MILS		
	MIN.	NOM.	MAX.	MIN.	NOM.	MAX.
A	-	-	1.20	-	-	47.2
A1	0.05	0.10	0.15	2.0	3.9	5.9
A2	0.95	1.00	1.05	37.4	39.4	41.3
b	0.30	-	0.45	11.8	-	17.7
c	0.12	-	0.21	4.7	-	8.3
D	18.212	18.415	18.618	717	725	733
E	11.506	11.760	12.014	453	463	473
E1	9.957	10.160	10.363	392	400	408
e	-	0.800	-	-	31.5	-
L	0.40	0.50	0.60	15.7	19.7	23.6
ZD	-	0.805	-	-	31.7	-
y	-	-	0.076	-	-	3
θ	0°	3°	6°	0°	3°	6°

ORDERING INFORMATION

Part Number	Organization	VCC Range	Package	Operating Temp	Speed (ns)
AS6C8016B-45ZIN	512K x 16	2.7 ~ 3.6V	44Pin 400mil TSOP II	Industrial -40°C ~ 85°C	45
AS6C8016B-55ZIN	512K x 16	2.7 ~ 3.6V	44Pin 400mil TSOP II	Industrial -40°C ~ 85°C	55

PART NUMBERING SYSTEM

AS6C	8016B	-45/55	T	I	N	XX
Low Power SRAM	Device Number 80 = 8Meg 16 = x16 B = B die version	Access Time -45 = 45ns -55 = 55ns	Package T= TSOP II	I=Industrial temp -40°C~ 85°C	Indicates Pb and Halogen Free	Packing Type None:Tray TR: Reel



Alliance Memory, Inc.
12815 NE 124th Street Suite D
Kirkland, WA 98034 USA
Tel: 425-898-4456
Fax: 425-896-8628
www.alliancememory.com

Copyright © Alliance Memory
All Rights Reserved

© Copyright 2007 Alliance Memory, Inc. All rights reserved. Our three-point logo, our name and Intelliwatt are trademarks or registered trademarks of Alliance. All other brand and product names may be the trademarks of their respective companies.

Alliance reserves the right to make changes to this document and its products at any time without notice.

Alliance assumes no responsibility for any errors that may appear in this document. The data contained herein represents Alliance's best data and/or estimates at the time of issuance. Alliance reserves the right to change or correct this data at any time, without notice.

If the product described herein is under development, significant changes to these specifications are possible. The information in this product data sheet is intended to be general descriptive information for potential customers and users, and is not intended to operate as, or provide, any guarantee or warrant to any user or customer.

Alliance does not assume any responsibility or liability arising out of the application or use of any product described herein, and disclaims any express or implied warranties related to the sale and/or use of Alliance products including liability or warranties related to fitness for a particular purpose, merchantability, or infringement of any intellectual property rights, except as express agreed to in Alliance's Terms and Conditions of Sale (which are available from Alliance). All sales of Alliance products are made exclusively according to Alliance's Terms and Conditions of Sale.

The purchase of products from Alliance does not convey a license under any patent rights, copyrights; mask works rights, trademarks, or any other intellectual property rights of Alliance or third parties. Alliance does not authorize its products for use as critical components in life-supporting systems where a malfunction or failure may reasonably be expected to result in significant injury to the user, and the inclusion of Alliance products in such life-supporting systems implies that the manufacturer assumes all risk of such use and agrees to indemnify Alliance against all claims arising from such use.