

## Trench gate field-stop IGBT, H series 1200 V, 25 A high speed

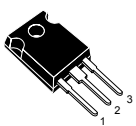

TO-247

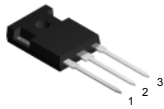

TO-247 long leads

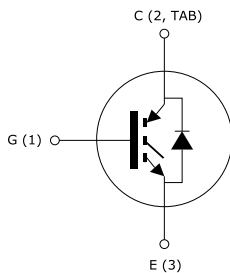

## Features

- Maximum junction temperature:  $T_J = 175\text{ °C}$
- High speed switching series
- Minimized tail current
- $V_{CE(sat)} = 2.1\text{ V (typ.) @ } I_C = 25\text{ A}$
- 5  $\mu\text{s}$  minimum short circuit withstand time at  $T_J = 150\text{ °C}$
- Safe paralleling
- Low thermal resistance
- Very fast recovery antiparallel diode

## Applications

- Photovoltaic inverters
- Uninterruptible power supply
- Welding
- Power factor correction
- High frequency converters

## Description

This device is an IGBT developed using an advanced proprietary trench gate field-stop structure. The device is part of the H series of IGBTs, which represents an optimum compromise between conduction and switching losses to maximize the efficiency of high-switching frequency converters. Furthermore, a slightly positive  $V_{CE(sat)}$  temperature coefficient and very tight parameter distribution result in safer paralleling operation.



## Product status links

[STGW25H120DF2](#)
[STGWA25H120DF2](#)

## Product summary

Order code	STGW25H120DF2
Marking	G25H120DF2
Package	TO-247
Packing	Tube
Order code	STGWA25H120DF2
Marking	G25H120DF2
Package	TO-247 long leads
Packing	Tube

# 1 Electrical ratings

**Table 1. Absolute maximum ratings**

Symbol	Parameter	Value	Unit
$V_{CES}$	Collector-emitter voltage ( $V_{GE} = 0\text{ V}$ )	1200	V
$I_C$	Continuous collector current at $T_C = 25\text{ °C}$	50	A
	Continuous collector current at $T_C = 100\text{ °C}$	25	
$I_{CP}^{(1)}$	Pulsed collector current	100	A
$V_{GE}$	Gate-emitter voltage	$\pm 20$	V
	Transient gate-emitter voltage ( $t_p \leq 10\text{ }\mu\text{s}$ , $D \leq 0.01$ )	$\pm 30$	
$I_F$	Continuous forward current at $T_C = 25\text{ °C}$	50	A
	Continuous forward current at $T_C = 100\text{ °C}$	25	
$I_{FP}^{(1)}$	Pulsed forward current	100	A
$P_{TOT}$	Total power dissipation at $T_C = 25\text{ °C}$	375	W
$T_J$	Operating junction temperature range	- 55 to 175	°C
$T_{STG}$	Storage temperature range	- 55 to 150	°C

1. Pulse width limited by maximum junction temperature.

**Table 2. Thermal data**

Symbol	Parameter	Value	Unit
$R_{thJC}$	Thermal resistance, junction-to-case IGBT	0.4	°C/W
	Thermal resistance, junction-to-case diode	1.47	
$R_{thJA}$	Thermal resistance, junction-to-ambient	50	°C/W

## 2 Electrical characteristics

$T_J = 25\text{ °C}$  unless otherwise specified.

**Table 3. Static characteristics**

Symbol	Parameter	Test conditions	Min.	Typ.	Max.	Unit
$V_{(BR)CES}$	Collector-emitter breakdown voltage	$V_{GE} = 0\text{ V}, I_C = 2\text{ mA}$	1200			V
$V_{CE(sat)}$	Collector-emitter saturation voltage	$V_{GE} = 15\text{ V}, I_C = 25\text{ A}$		2.1	2.6	V
		$V_{GE} = 15\text{ V}, I_C = 25\text{ A}, T_J = 125\text{ °C}$		2.4		
		$V_{GE} = 15\text{ V}, I_C = 25\text{ A}, T_J = 175\text{ °C}$		2.5		
$V_F$	Forward on-voltage	$I_F = 25\text{ A}$		3.8	4.9	V
		$I_F = 25\text{ A}, T_J = 125\text{ °C}$		3.05		
		$I_F = 25\text{ A}, T_J = 175\text{ °C}$		2.8		
$V_{GE(th)}$	Gate threshold voltage	$V_{CE} = V_{GE}, I_C = 1\text{ mA}$	5	6	7	V
$I_{CES}$	Collector cut-off current	$V_{GE} = 0\text{ V}, V_{CE} = 1200\text{ V}$			25	$\mu\text{A}$
$I_{GES}$	Gate-emitter leakage current	$V_{CE} = 0\text{ V}, V_{GE} = \pm 20\text{ V}$			250	nA

**Table 4. Dynamic characteristics**

Symbol	Parameter	Test conditions	Min.	Typ.	Max.	Unit
$C_{ies}$	Input capacitance	$V_{CE} = 25\text{ V}, f = 1\text{ MHz}, V_{GE} = 0\text{ V}$	-	2010	-	pF
$C_{oes}$	Output capacitance		-	146	-	pF
$C_{res}$	Reverse transfer capacitance		-	49	-	pF
$Q_g$	Total gate charge	$V_{CC} = 960\text{ V}, I_C = 25\text{ A}, V_{GE} = 0\text{ to }15\text{ V}$ (see Figure 28. Gate charge test circuit)	-	100	-	nC
$Q_{ge}$	Gate-emitter charge		-	11	-	nC
$Q_{gc}$	Gate-collector charge		-	52	-	nC

**Table 5. IGBT switching characteristics (inductive load)**

Symbol	Parameter	Test conditions	Min.	Typ.	Max.	Unit
$t_{d(on)}$	Turn-on delay time	$V_{CE} = 600\text{ V}$ , $I_C = 25\text{ A}$ , $R_G = 10\ \Omega$ , $V_{GE} = 15\text{ V}$ (see Figure 27. Test circuit for inductive load switching)		29	-	ns
$t_r$	Current rise time			12	-	ns
$(di/dt)_{on}$	Turn-on current slope			1774	-	A/ $\mu$ s
$t_{d(off)}$	Turn-off delay time			130	-	ns
$t_f$	Current fall time			106	-	ns
$E_{on}^{(1)}$	Turn-on switching energy			0.6	-	mJ
$E_{off}^{(2)}$	Turn-off switching energy			0.7	-	mJ
$E_{ts}$	Total switching energy			1.3	-	mJ
$t_{d(on)}$	Turn-on delay time	$V_{CE} = 600\text{ V}$ , $I_C = 25\text{ A}$ , $R_G = 10\ \Omega$ , $V_{GE} = 15\text{ V}$ , $T_J = 175\text{ }^\circ\text{C}$ (see Figure 27. Test circuit for inductive load switching)		27.5	-	ns
$t_r$	Current rise time			13.5	-	ns
$(di/dt)_{on}$	Turn-on current slope			1522	-	A/ $\mu$ s
$t_{d(off)}$	Turn-off delay time			139	-	ns
$t_f$	Current fall time			200	-	ns
$E_{on}^{(1)}$	Turn-on switching energy			1.05	-	mJ
$E_{off}^{(2)}$	Turn-off switching energy			1.65	-	mJ
$E_{ts}$	Total switching energy			2.7	-	mJ
$t_{sc}$	Short-circuit withstand time	$V_{CE} = 600\text{ V}$ , $V_{GE} = 15\text{ V}$ , $T_J = 150\text{ }^\circ\text{C}$ ,	5		-	$\mu$ s

1. Including the reverse recovery of the diode.

2. Including the tail of the collector current.

**Table 6. Diode switching characteristics (inductive load)**

Symbol	Parameter	Test conditions	Min.	Typ.	Max.	Unit	
$t_{rr}$	Reverse recovery time	$I_F = 25\text{ A}$ , $V_R = 600\text{ V}$ , $di/dt = 500\text{ A}/\mu\text{s}$ , $V_{GE} = 15\text{ V}$ (see Figure 27. Test circuit for inductive load switching)	-	303	-	ns	
$Q_{rr}$	Reverse recovery charge			-	0.93	-	$\mu$ C
$I_{rrm}$	Reverse recovery current			-	15.3	-	A
$dI_{rr}/dt$	Peak rate of fall of reverse recovery current during $t_b$			-	400	-	A/ $\mu$ s
$E_{rr}$	Reverse recovery energy			-	0.52	-	mJ
$t_{rr}$	Reverse recovery time	$I_F = 25\text{ A}$ , $V_R = 600\text{ V}$ , $di/dt = 500\text{ A}/\mu\text{s}$ , $V_{GE} = 15\text{ V}$ , $T_J = 175\text{ }^\circ\text{C}$ (see Figure 27. Test circuit for inductive load switching)	-	508	-	ns	
$Q_{rr}$	Reverse recovery charge			-	2.71	-	$\mu$ C
$I_{rrm}$	Reverse recovery current			-	23	-	A
$dI_{rr}/dt$	Peak rate of fall of reverse recovery current during $t_b$			-	680	-	A/ $\mu$ s
$E_{rr}$	Reverse recovery energy			-	1.56	-	mJ

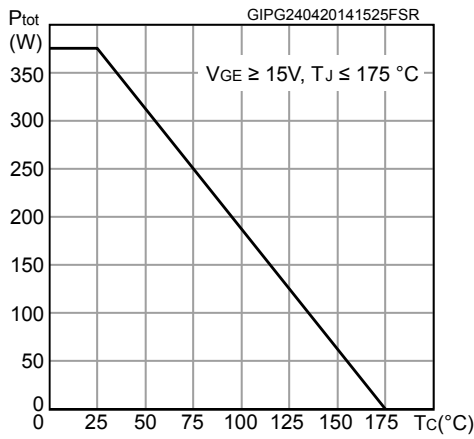
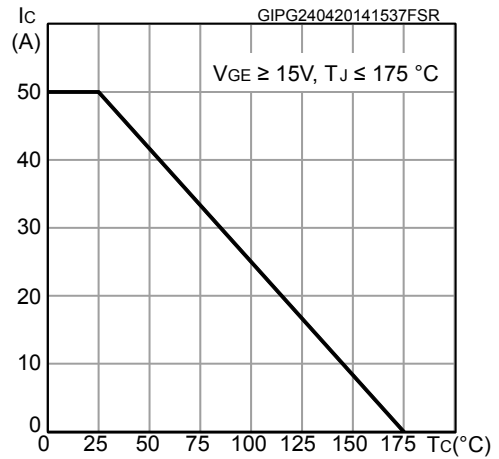
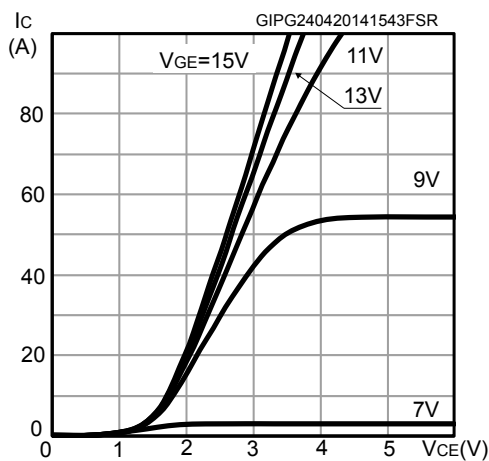
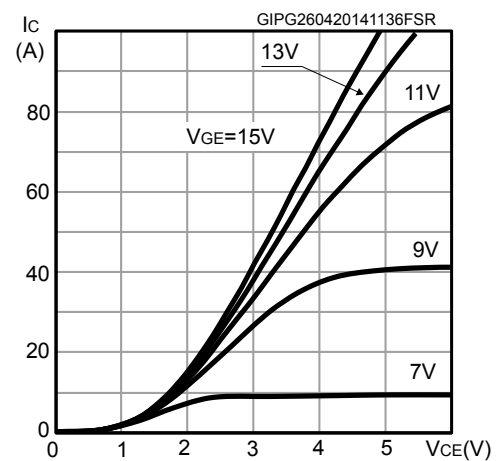
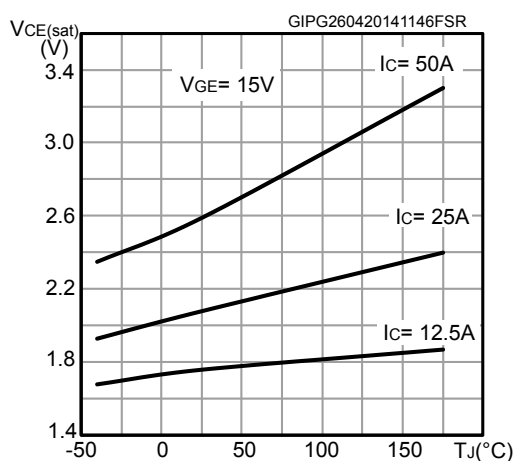
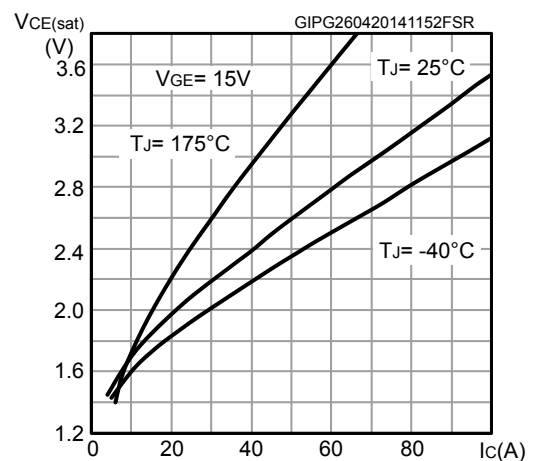
**2.1 Electrical characteristics (curves)**
**Figure 1. Power dissipation vs case temperature**

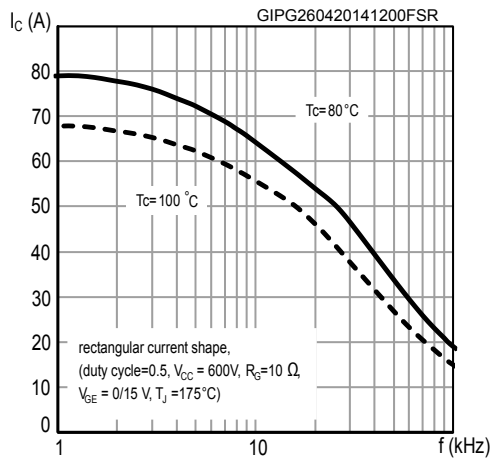
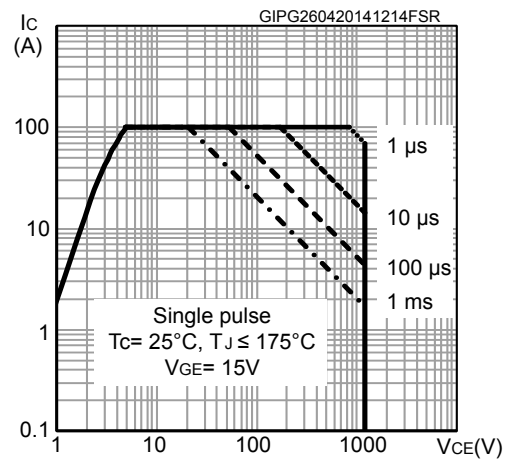
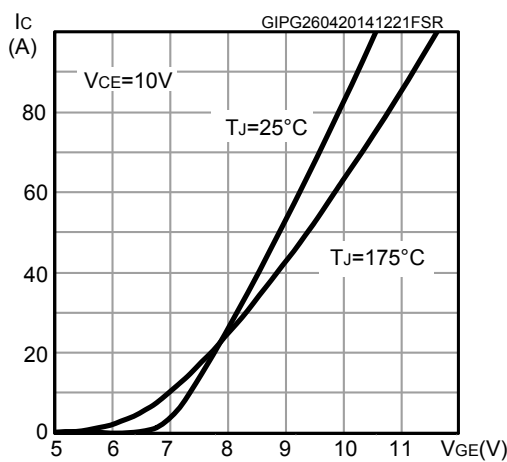
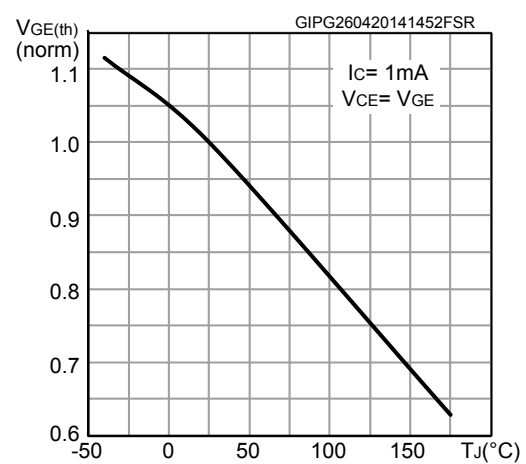
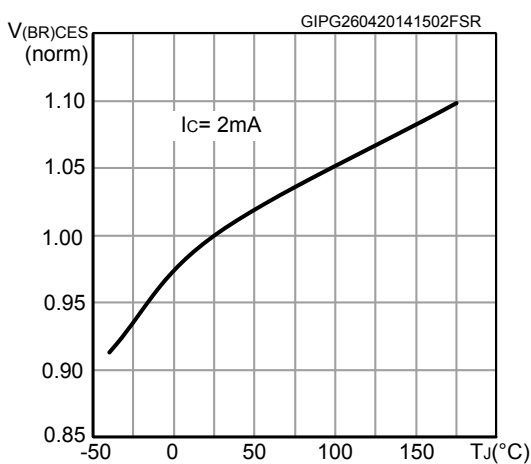
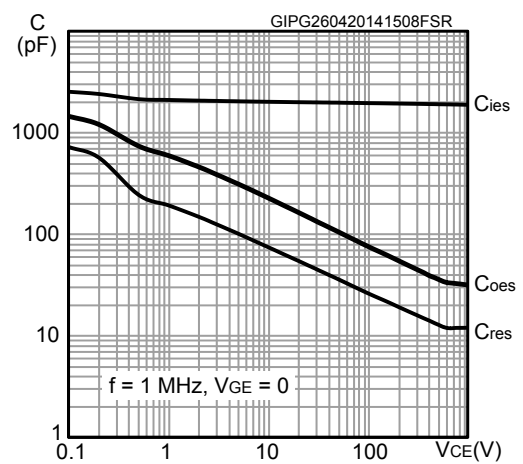
**Figure 2. Collector current vs case temperature**

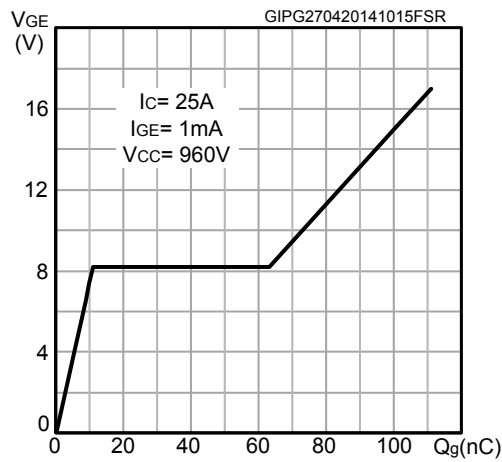
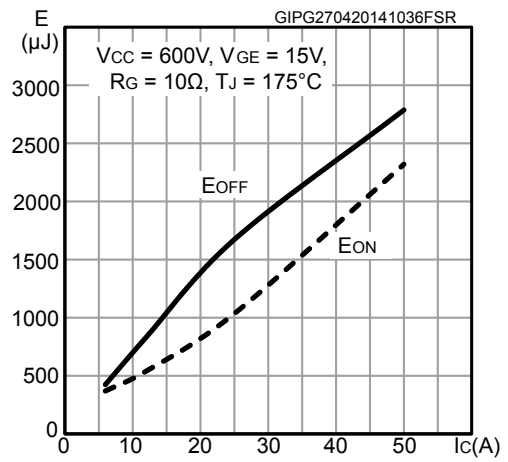
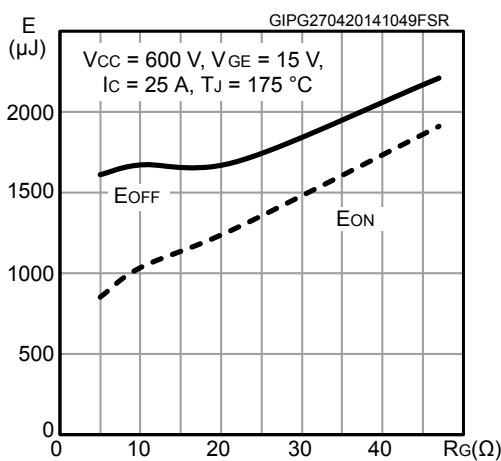
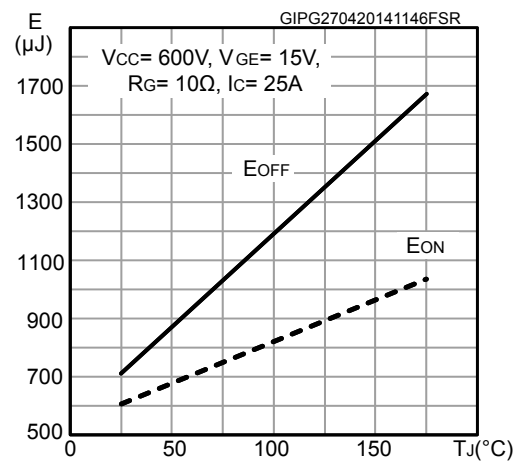
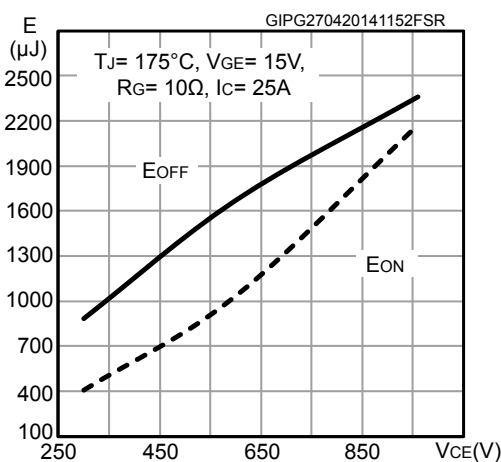
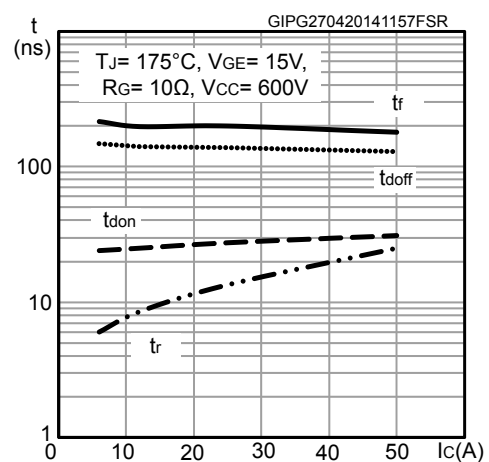
**Figure 3. Output characteristics ( $T_J = 25^\circ\text{C}$ )**

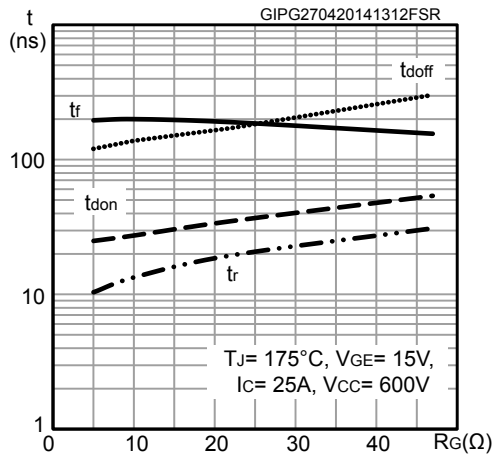
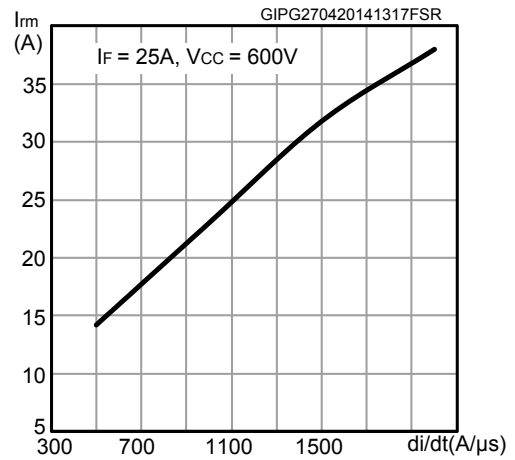
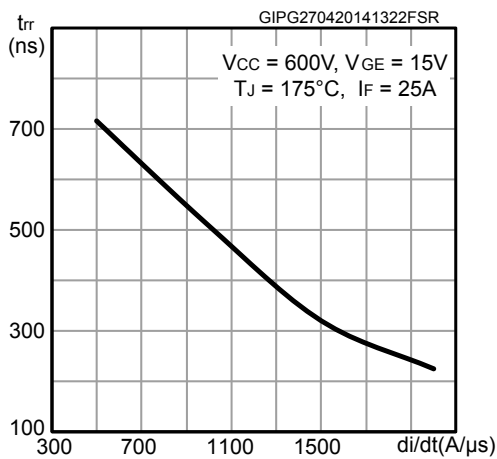
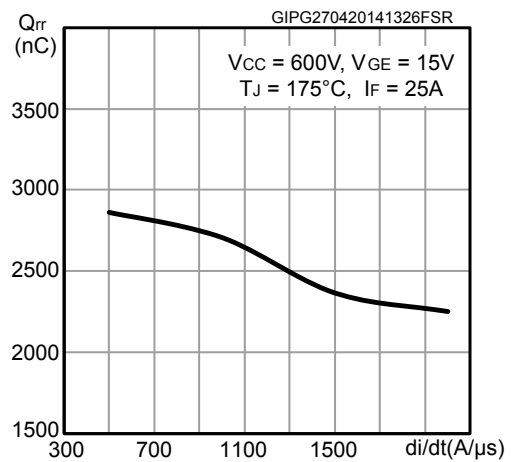
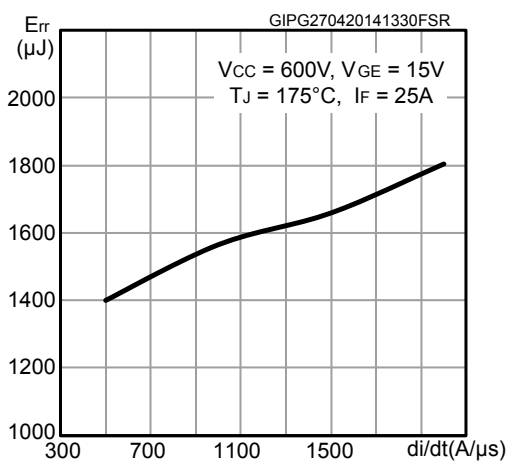
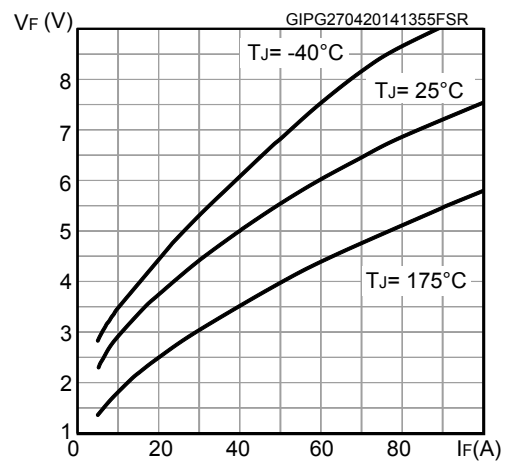
**Figure 4. Output characteristics ( $T_J = 175^\circ\text{C}$ )**

**Figure 5.  $V_{CE(sat)}$  vs junction temperature**

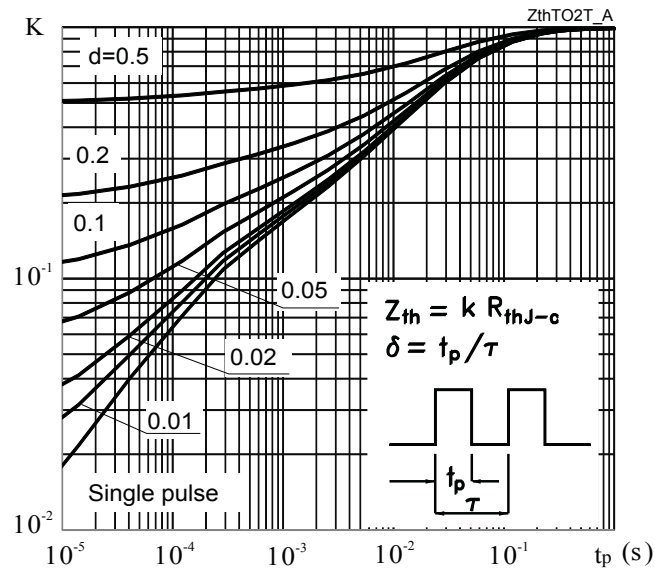
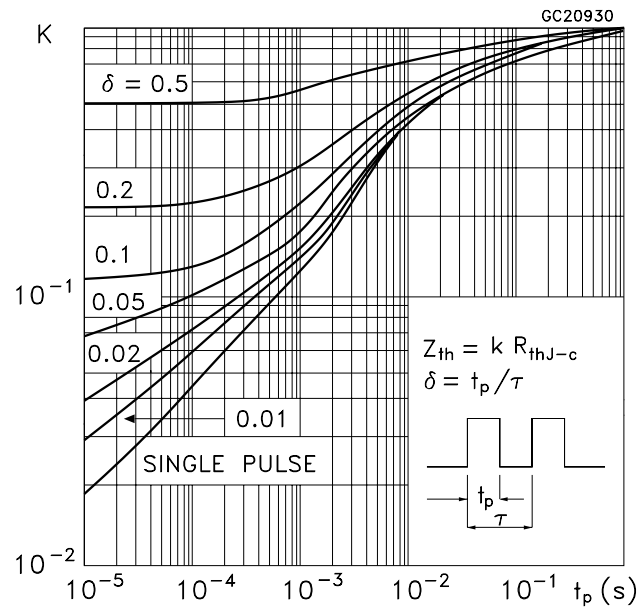
**Figure 6.  $V_{CE(sat)}$  vs collector current**

**Figure 7. Collector current vs switching frequency**

**Figure 8. Safe operating area**

**Figure 9. Transfer characteristics**

**Figure 10. Diode V<sub>F</sub> vs forward current**

**Figure 11. Normalized V<sub>(BR)CES</sub> vs junction temperature**

**Figure 12. Capacitance variations**

**Figure 13. Gate charge vs gate-emitter voltage**

**Figure 14. Switching energy vs collector current**

**Figure 15. Switching energy vs gate resistance**

**Figure 16. Switching energy vs junction temperature**

**Figure 17. Switching energy vs collector-emitter voltage**

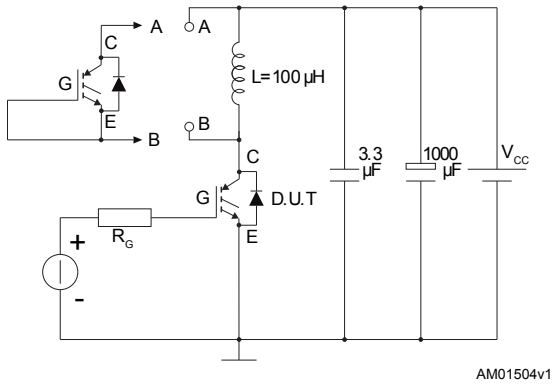
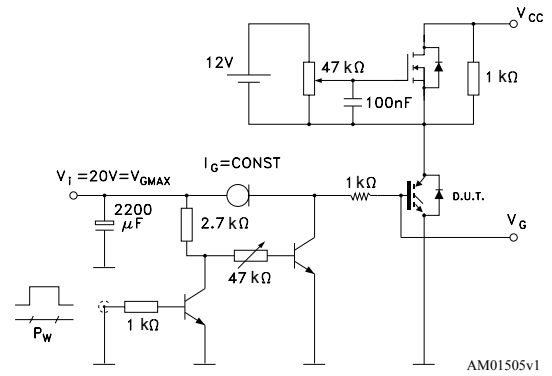
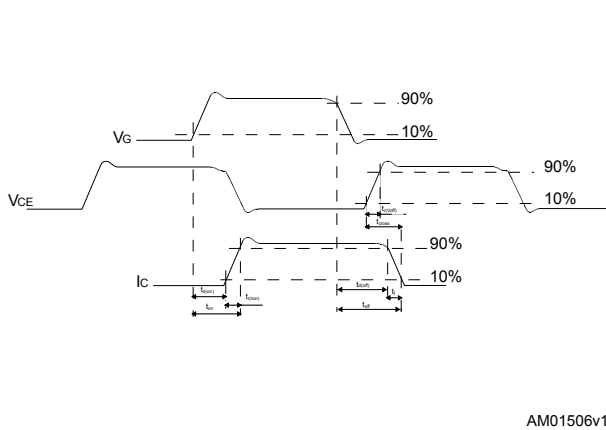
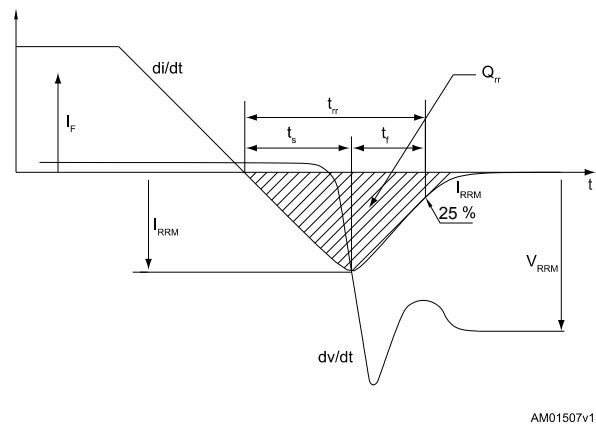
**Figure 18. Switching times vs collector current**

**Figure 19. Switching times vs gate resistance**

**Figure 20. Reverse recovery current vs diode current slope**

**Figure 21. Reverse recovery time vs diode current slope**

**Figure 22. Reverse recovery charge vs diode current slope**

**Figure 23. Reverse recovery energy vs diode current slope**

**Figure 24. Diode VF vs forward current**



**Figure 25. Thermal impedance for IGBT**

**Figure 26. Thermal impedance for diode**

### 3 Test circuits

**Figure 27. Test circuit for inductive load switching**

**Figure 28. Gate charge test circuit**

**Figure 29. Switching waveform**

**Figure 30. Diode reverse recovery waveform**

## 4 Package information

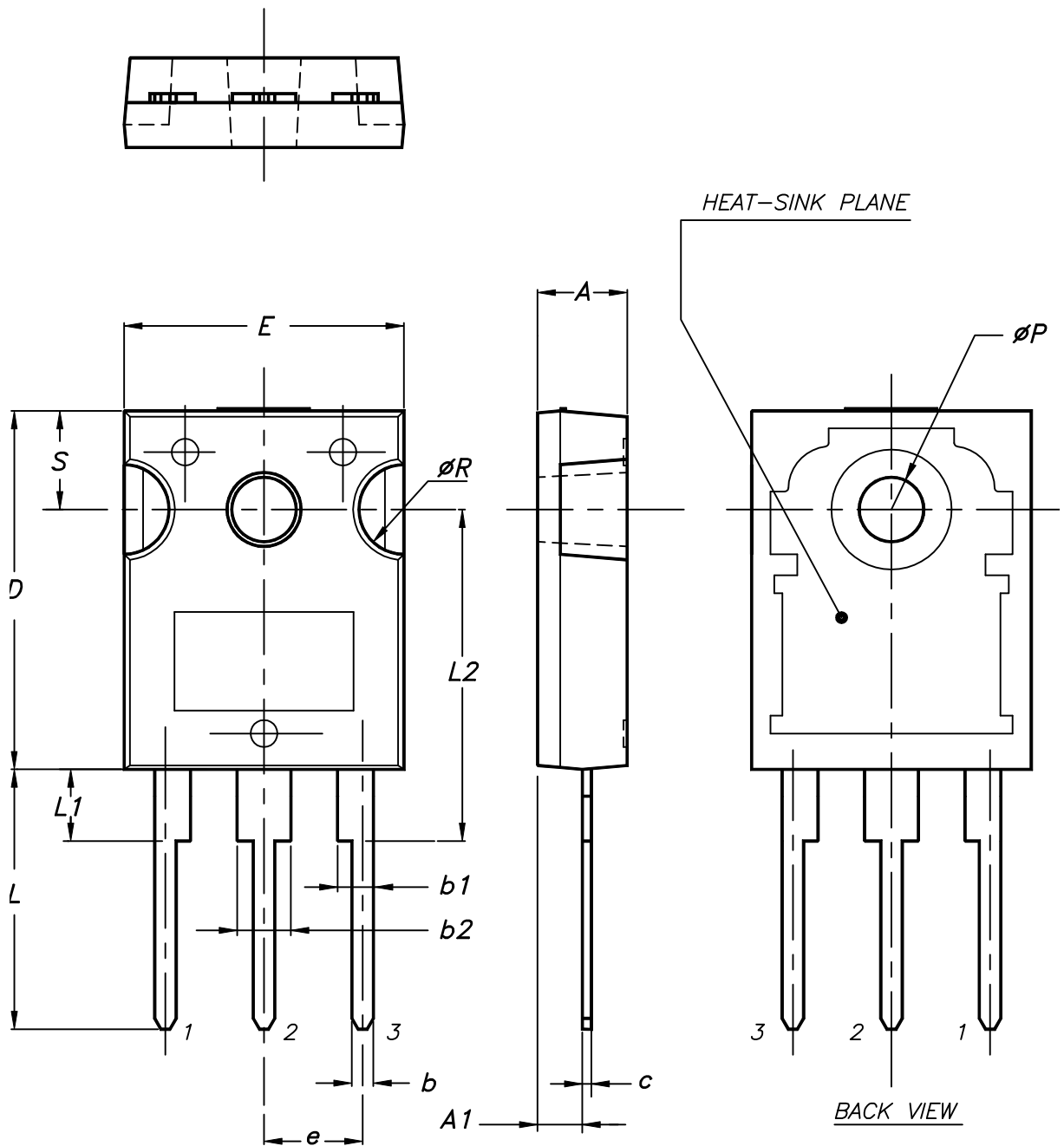
In order to meet environmental requirements, ST offers these devices in different grades of **ECOPACK** packages, depending on their level of environmental compliance. ECOPACK specifications, grade definitions and product status are available at: [www.st.com](http://www.st.com). ECOPACK is an ST trademark.

### 4.1 TO-247 package information

Figure 31. TO-247 package outline



0075325\_9

Table 7. TO-247 package mechanical data

Dim.	mm		
	Min.	Typ.	Max.
A	4.85		5.15
A1	2.20		2.60
b	1.0		1.40
b1	2.0		2.40
b2	3.0		3.40
c	0.40		0.80
D	19.85		20.15
E	15.45		15.75
e	5.30	5.45	5.60
L	14.20		14.80
L1	3.70		4.30
L2		18.50	
ØP	3.55		3.65
ØR	4.50		5.50
S	5.30	5.50	5.70

## 4.2 TO-247 long leads package information

Figure 32. TO-247 long leads package outline

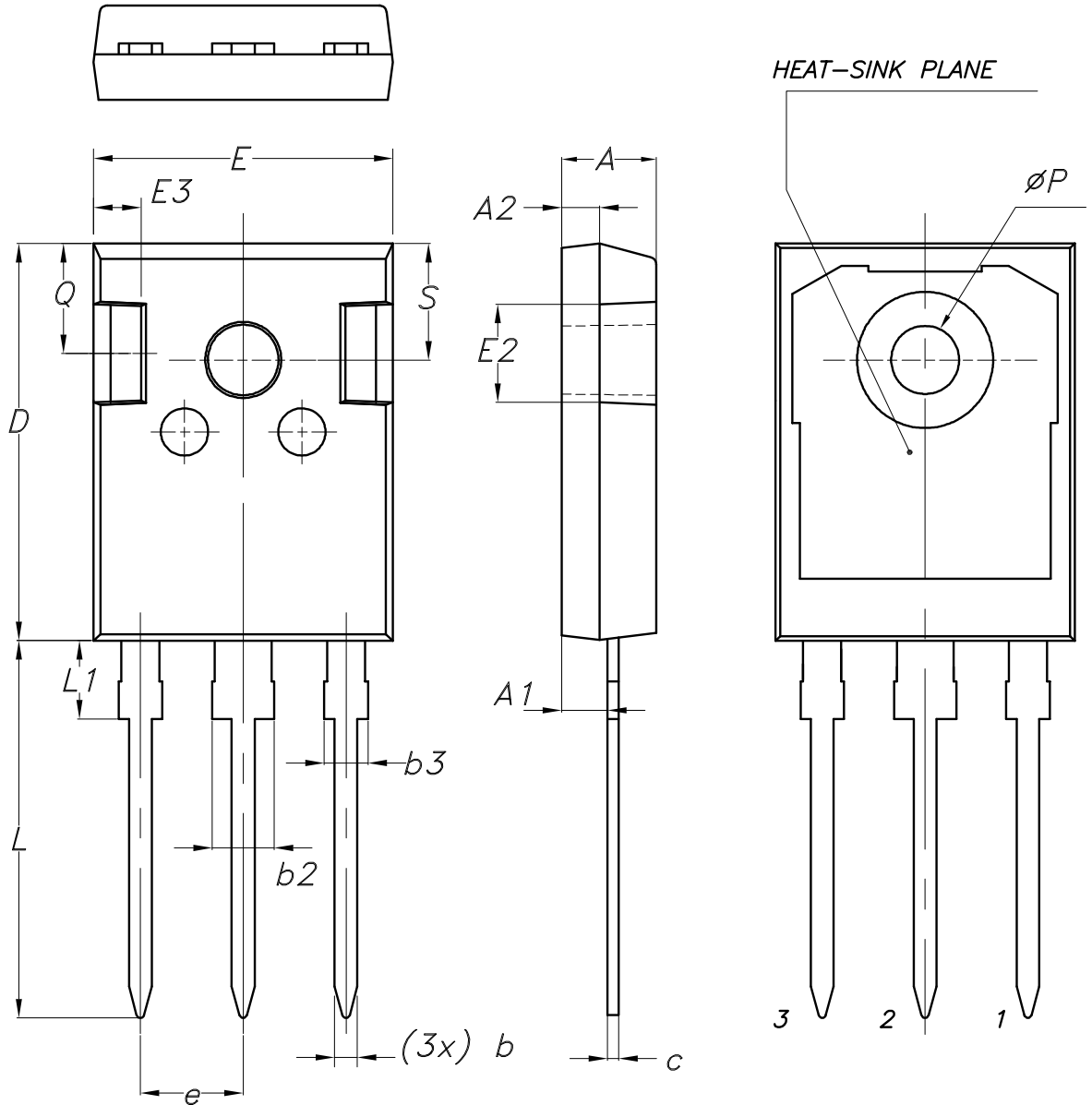

8463846\_2\_F

**Table 8. TO-247 long leads package mechanical data**

Dim.	mm		
	Min.	Typ.	Max.
A	4.90	5.00	5.10
A1	2.31	2.41	2.51
A2	1.90	2.00	2.10
b	1.16		1.26
b2			3.25
b3			2.25
c	0.59		0.66
D	20.90	21.00	21.10
E	15.70	15.80	15.90
E2	4.90	5.00	5.10
E3	2.40	2.50	2.60
e	5.34	5.44	5.54
L	19.80	19.92	20.10
L1			4.30
P	3.50	3.60	3.70
Q	5.60		6.00
S	6.05	6.15	6.25

## Revision history

**Table 9. Document revision history**

Date	Revision	Changes
03-Oct-2012	1	Initial release.
28-Feb-2014	2	Updated title and features in cover page. Minor text changes.
31-Mar-2014	3	Document status promoted from preliminary to production data. Updated <i>Table 4: Static characteristics</i> and <i>Table 6: IGBT switching characteristics (inductive load)</i> . Added Section 2.1: Electrical characteristics (curves).
06-Mar-2015	4	Added 4.2: <i>TO-247 long leads, package information</i> . Minor text changes.
10-Mar-2021	5	Updated <i>Table 1. Absolute maximum ratings</i> . Minor text changes.

---

## Contents

<b>1</b>	<b>Electrical ratings</b> .....	<b>2</b>
<b>2</b>	<b>Electrical characteristics</b> .....	<b>3</b>
<b>2.1</b>	Electrical characteristics (curves) .....	<b>5</b>
<b>3</b>	<b>Test circuits</b> .....	<b>10</b>
<b>4</b>	<b>Package information</b> .....	<b>11</b>
<b>4.1</b>	TO-247 package information .....	11
<b>4.2</b>	TO-247 long leads package information .....	13
	<b>Revision history</b> .....	<b>15</b>





**IMPORTANT NOTICE – PLEASE READ CAREFULLY**

STMicroelectronics NV and its subsidiaries (“ST”) reserve the right to make changes, corrections, enhancements, modifications, and improvements to ST products and/or to this document at any time without notice. Purchasers should obtain the latest relevant information on ST products before placing orders. ST products are sold pursuant to ST’s terms and conditions of sale in place at the time of order acknowledgement.

Purchasers are solely responsible for the choice, selection, and use of ST products and ST assumes no liability for application assistance or the design of Purchasers’ products.

No license, express or implied, to any intellectual property right is granted by ST herein.

Resale of ST products with provisions different from the information set forth herein shall void any warranty granted by ST for such product.

ST and the ST logo are trademarks of ST. For additional information about ST trademarks, please refer to [www.st.com/trademarks](http://www.st.com/trademarks). All other product or service names are the property of their respective owners.

Information in this document supersedes and replaces information previously supplied in any prior versions of this document.

© 2021 STMicroelectronics – All rights reserved