

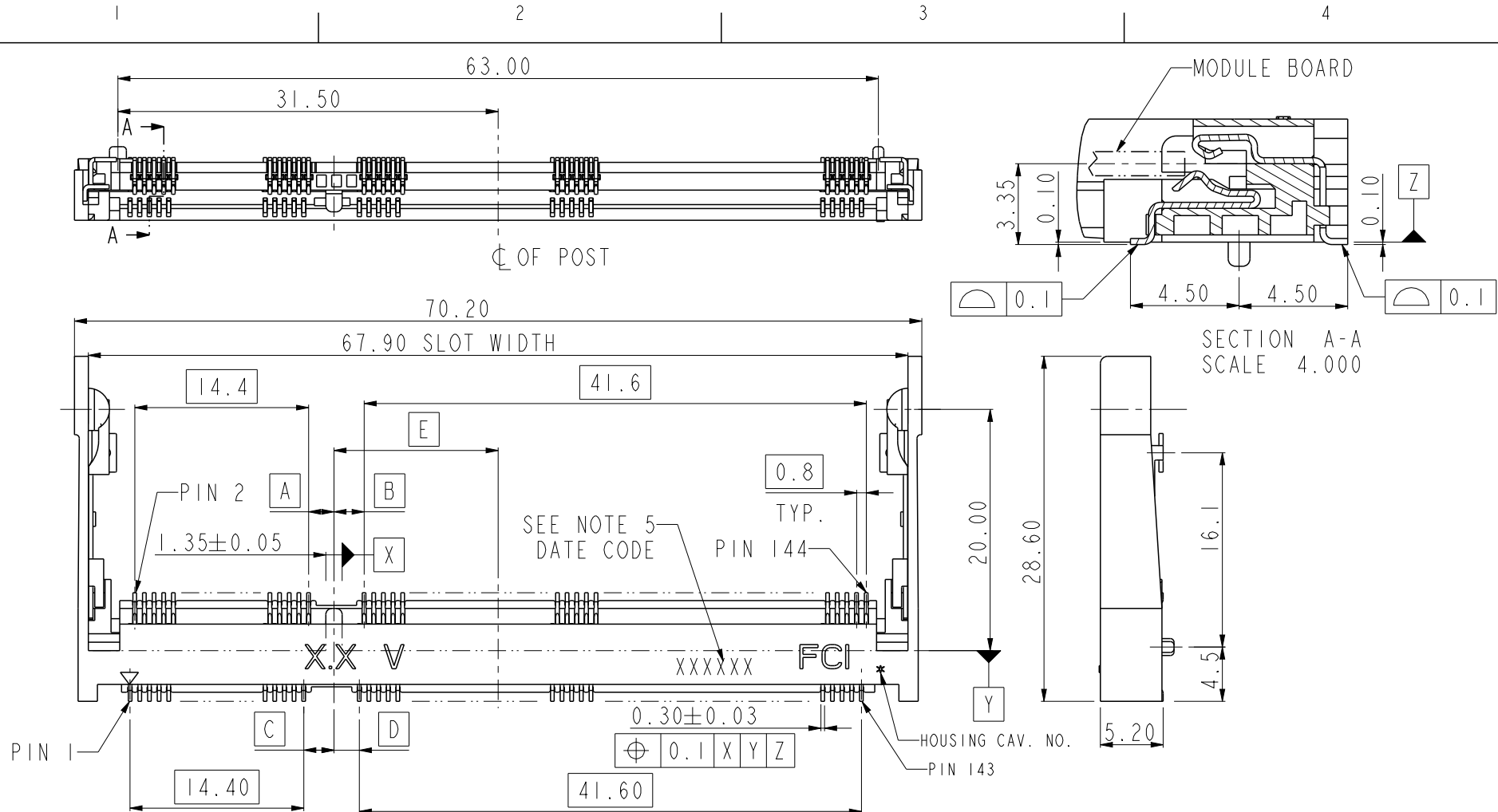

Copyright FCI.



1.5V	2.85	1.75	3.25	1.35	12.85
2.5V	1.35	3.25	1.75	2.85	14.35
1.8V	2.10	2.50	2.50	2.10	13.60
POWER SUPPLY	DIM.A	DIM.B	DIM.C	DIM.D	DIM.E

spec ref	*	dr	Rick Bian	2010/07/03	projection	MM	size	A4	scale	1.000												
tolerance std	TOLERANCES UNLESS OTHERWISE SPECIFIED	eng	Terris Liu	2014/01/21			ecn no		ELX-DG-13430-1													
		chr	Tian-Xu Huang	2014/01/22			rel level		Released													
surface	<table border="1"> <tr> <td>linear</td> <td>0.X</td> <td>±0.38</td> </tr> <tr> <td></td> <td>0.XX</td> <td>±0.25</td> </tr> <tr> <td></td> <td>0.XXX</td> <td>±0.13</td> </tr> <tr> <td>angular</td> <td>0°</td> <td>±2°</td> </tr> </table>	linear	0.X	±0.38		0.XX	±0.25		0.XXX	±0.13	angular	0°	±2°	appr	Pei-Ming Zheng	2014/01/22	product family		SO DIMM		rev	
linear	0.X	±0.38																				
	0.XX	±0.25																				
	0.XXX	±0.13																				
angular	0°	±2°																				
				title		SO DIMM SOCKET, P=0.8mm		dwg no		10062086												
		www.fci.com		cat. no.		10062086		Product - Customer Drw		sheet 1 of 4												

ProjE File - REV C - 2009-06-09



Copyright FCI.

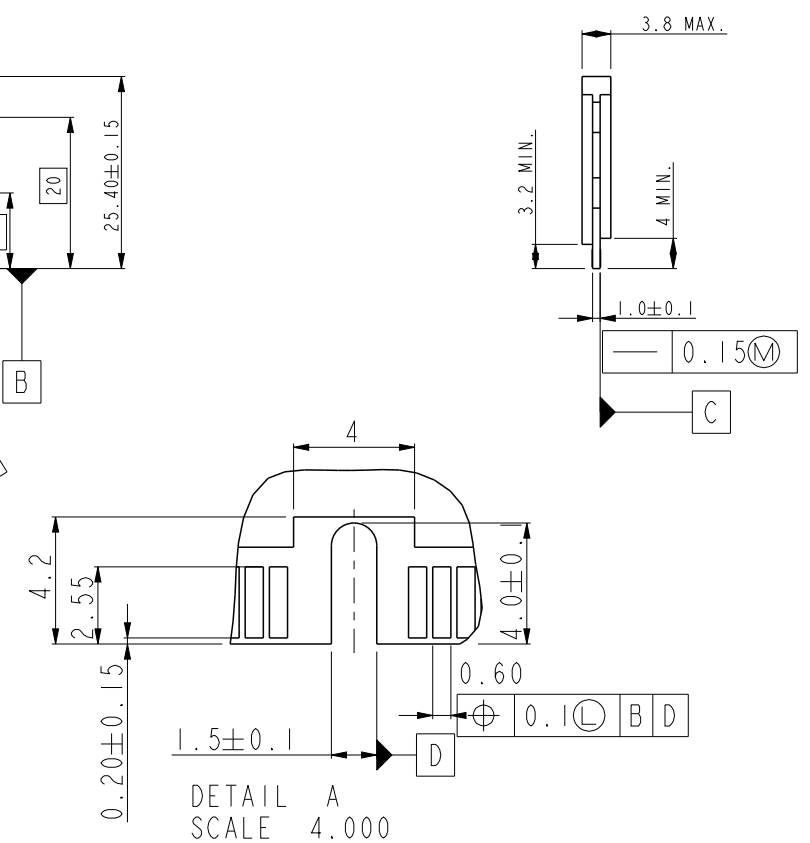
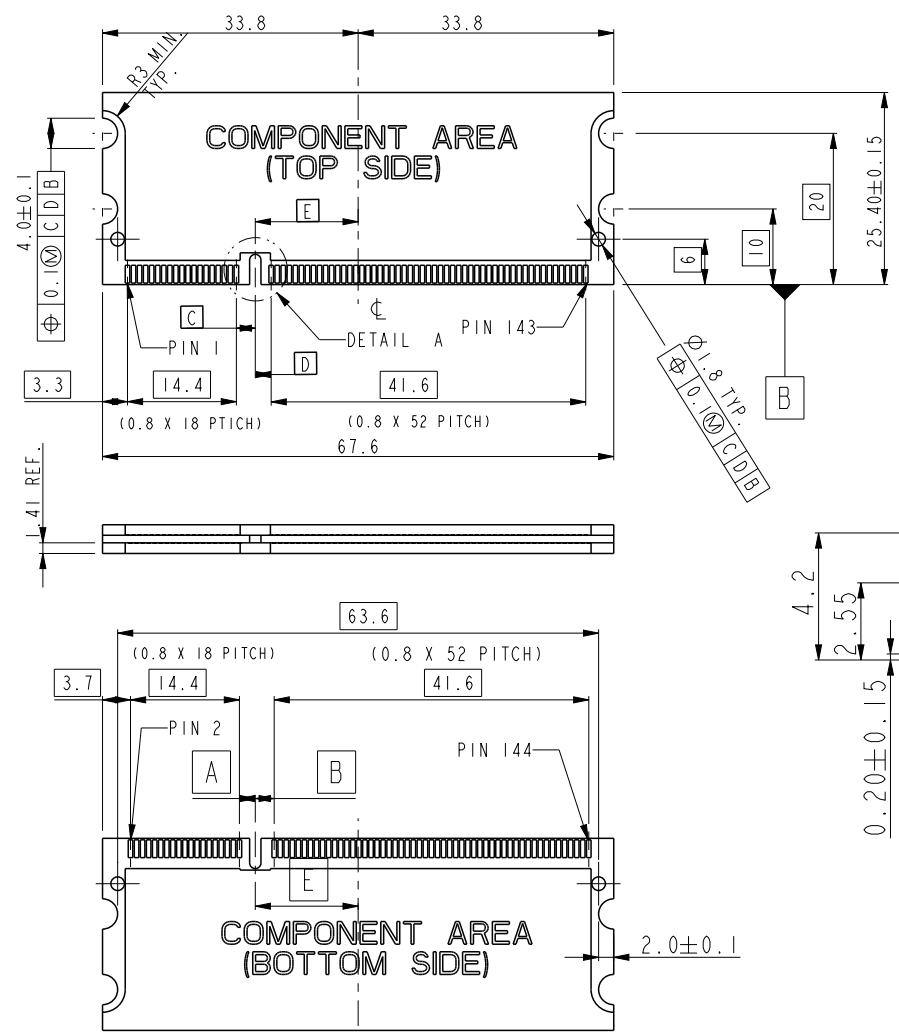

1.5V	2.85	1.75	3.25	1.35	12.85
2.5V	1.35	3.25	1.75	2.85	14.35
1.8V	2.10	2.50	2.50	2.10	13.60
POWER SUPPLY	DIM.A	DIM.B	DIM.C	DIM.D	DIM.E

dr	Rick Bian	2010/07/03	projection 	MM 	size	A4	scale	1.000	
eng	Terris Liu	2014/01/21			ecn no	ELX-DG-13430-1			
chr	Tian-Xu Huang	2014/01/22			rel level	Released			
TOLERANCE UNLESS OTHERWISE SPECIFIED			appr	Pei-Ming Zheng	2014/01/22	product family	-		
LINEAR	.X ±.20		title SO DIMM SOCKET, P=0.8mm 144 POSITION, STD PROFILE			dwg no	10062086		rev D
	.XX ±.10								
.XXX ±.05									
ANGLES	0°±2°	www.fci.com	cat. no.	-	Product - Customer Drw		sheet 2 of 4		



Copyright FCI.

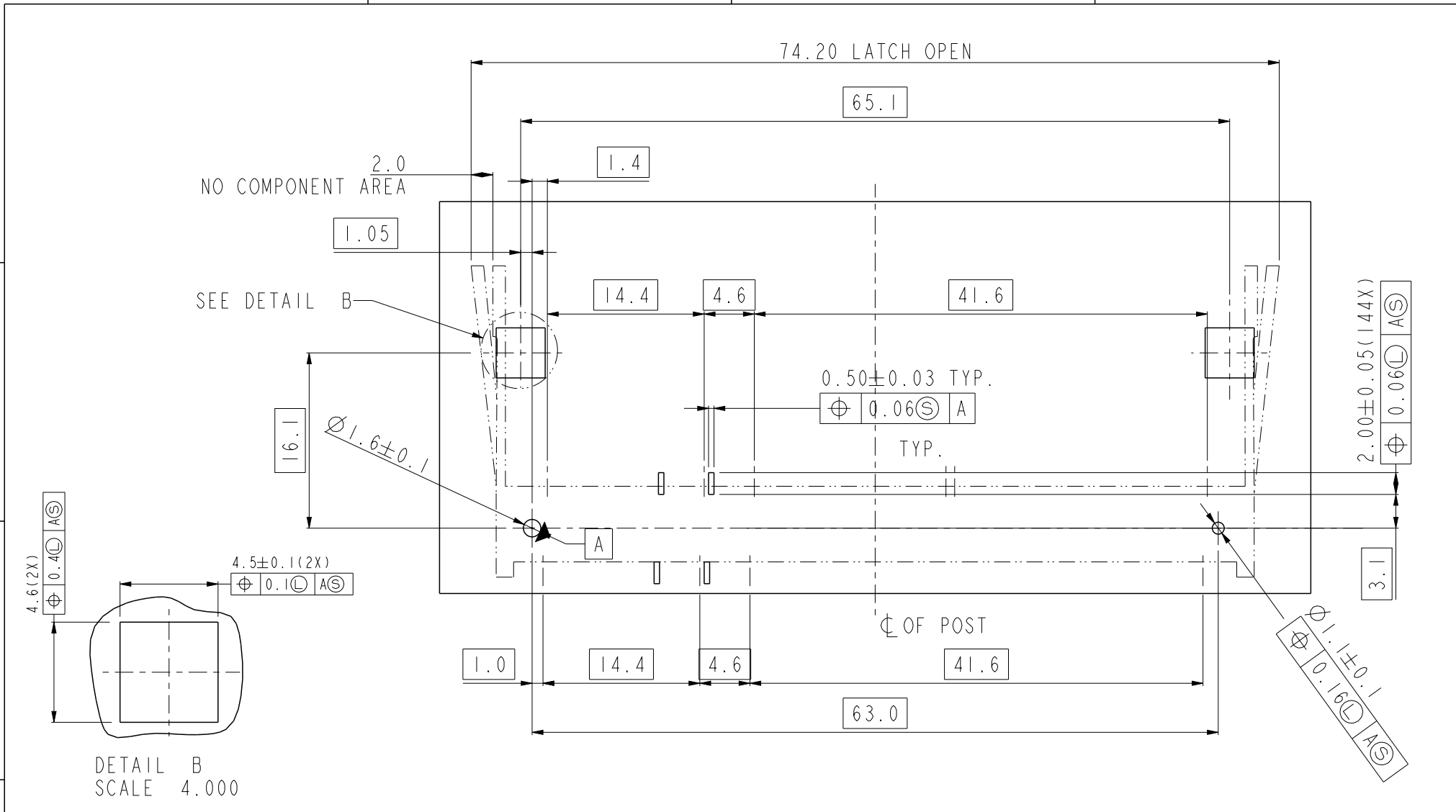

DETAIL B
SCALE 4.000

TOLERANCE UNLESS OTHERWISE SPECIFIED	
LINEAR	.X ±.30
	.XX ±.20
	.XXX ±.10
ANGLES	0°±2°

dr	Rick Bian	2010/07/03
eng	Terris Liu	2014/01/21
chr	Tian-Xu Huang	2014/01/22
appr	Pei-Ming Zheng	2014/01/22

projection	
product family	-

size	A4
ecn no	ELX-DG-13430-1
rel level	Released

scale	1.000
rev	D



title	SO DIMM SOCKET, P=0.8mm 144 POSITION, STD PROFILE
cat. no.	-

dwg no	10062086
Product - Customer Drw	sheet 3 of 4

A

A

10062086-X X X X LF

LEAD FREE AND RoHS COMPATIBLE
 0: REEL PACKAGING
 UNAVAILABLE: TRAY PACKAGING

PLATING

CODE	CONTACT AREA	SOLDER PAD	UNDERPLATING
1	0.25um MIN. GOLD	1.75um MIN. MATT Tin	1.27um MIN. NICKEL OVERALL
2	GOLD FLASH		
5	0.25um MIN. GOLD	GOLD FLASH	
6	GOLD FLASH		

0: IVORY HSG
 1: BLACK HSG

1: FOR 1.5V
 2: FOR 1.8V
 3: FOR 2.5V

NOTE:

- MATERIAL:
 HOUSING: LCP, UL94V-0
 CONTACT: PHOSPHOR BRONZE
 LATCH : COPPER ALLOY
- TWIST: 0.10mm MAX.
- PRODUCT SPEC: GS-12-364
- TRAY PACKAGE PER GS-14-368;
 REEL PACKAGE PER GS-14-1127
- DATE CODE PRINTED AS "DDMMYY".
- THIS PRODUCT MEETS EUROPEAN UNION DIRECTIVES AND OTHER COUNTRY REGULATIONS AS DESCRIBED IN GS-22-008.
- THE HOUSING WILL WITHSTAND EXPOSURE TO 260°C PEAK TEMPERATURE FOR 10-30 SECS IN A CONVECTION, INFAR-RED OR VAPORPHASE REFLOW OVEN. SEE APPLICATION NOTES/PROCEDURES IF THEY ARE AVAILABLE.

B

B

C

C



Copyright FCI.

D

D

dr	Rick Bian	2010/07/03	projection 	MM 	size	A4	scale	1.000
eng	Terris Liu	2014/01/21			ecn no	ELX-DG-13430-1		
chr	Tian-Xu Huang	2014/01/22			rel level	Released		
appr	Pei-Ming Zheng	2014/01/22	product family	-	rev	10062086		D
		title	SO DIMM SOCKET, P=0.8mm		cat. no.	Product - Customer Drw		sheet 4 of 4
www.fci.com		144 POSITION, STD PROFILE		dwg no	10062086			