

# Product data sheet

Specifications



## sub-base - soldered solid state output relay ABE7 - 16 inputs - 48 V DC

ABE7S16E2E1

### Main

Range of product	Modicon ABE7
Product or component type	Solid state input relay sub-base
[Us] rated supply voltage	24 V DC (PLC end) 48 V DC (sensor end)
Number of channels	16
Number of terminal per channel	2
Connections - terminals	Screw type terminals, 1 x 0.09...1 x 1.5 mm <sup>2</sup> , 0.09...1.5 mm <sup>2</sup> (AWG 28...AWG 16) flexible with cable end Screw type terminals, 1 x 0.14...1 x 2.5 mm <sup>2</sup> , 0.14...2.5 mm <sup>2</sup> (AWG 26...AWG 12) solid Screw type terminals, 1 x 0.14...1 x 2.5 mm <sup>2</sup> , 0.14...2.5 mm <sup>2</sup> (AWG 26...AWG 14) flexible without cable end Screw type terminals, 2 x 0.09...2 x 0.75 mm <sup>2</sup> , 0.09...0.75 mm <sup>2</sup> (AWG 28...AWG 20) flexible with cable end Screw type terminals, 2 x 0.2...2 x 2.5 mm <sup>2</sup> , 0.2...2.5 mm <sup>2</sup> (AWG 24...AWG 14) solid

### Complementary

Terminal block type	Removable
Supply voltage limits	19...30 V DC (PLC end) conforming to IEC 61131-2
Isolation PLC/operative part	Yes
Protection type	Internal fuse 1 A 5 x 20 mm fast blow PLC end Adjustable by external fuse fast blow sensor end
Fixing mode	By clips (35 mm symmetrical DIN rail) By screws (solid plate with fixing kit)
Current per channel	0.013 A
Current state 1 guaranteed	>= 6 mA (sensor end)
Voltage state 1 guaranteed	>= 30 V for sensor end
Maximum switching current	15 mA (PLC end)
Minimum switching current	1 mA for PLC end
Response time	<= 0.05 ms from state 0 to 1 <= 0.4 ms from state 1 to 0
Switching frequency	<= 1000 Hz duty cycle: 50 %
[Uimp] rated impulse withstand voltage	2.5 kV conforming to IEC 60947-1
[Ui] rated insulation voltage	2000 V
Installation category	II conforming to IEC 60664-1
Tightening torque	0.6 N.m with flat Ø 3.5 mm screwdriver

Product weight	0.37 kg
<b>Environment</b>	
Dielectric strength	2000 V at 50/60 Hz conforming to IEC 60947-1
Product certifications	CSA UL DNV GL EAC
Standards	IEC 61131-2 Type 2
IP degree of protection	IP2X conforming to IEC 60529
Resistance to incandescent wire	750 °C conforming to IEC 60695-2-11
Shock resistance	15 gn for 11 ms conforming to IEC 60068-2-27
Vibration resistance	2 gn (f= 10...150 Hz) conforming to IEC 60068-2-6
Resistance to electrostatic discharge	4 kV (contact) level 3 conforming to IEC 61000-4-2 8 kV (air) level 3 conforming to IEC 61000-4-2
Resistance to radiated fields	10 V/m (26000000...1000000000 Hz) conforming to IEC 61000-4-3 level 3
Resistance to fast transients	2 kV level 3 conforming to IEC 61000-4-4
Ambient air temperature for operation	-5...60 °C conforming to IEC 61131-2
Ambient air temperature for storage	-40...80 °C conforming to IEC 61131-2
Pollution degree	2 conforming to IEC 60664-1

## Packing Units

Unit Type of Package 1	PCE
Number of Units in Package 1	1
Package 1 Height	7.0 cm
Package 1 Width	8.3 cm
Package 1 Length	21.1 cm
Package 1 Weight	446.0 g
Unit Type of Package 2	S03
Number of Units in Package 2	16
Package 2 Height	30.0 cm
Package 2 Width	30.0 cm
Package 2 Length	40.0 cm
Package 2 Weight	7.63 kg

## Offer Sustainability

Sustainable offer status	Green Premium product
REACH Regulation	<a href="#">REACH Declaration</a>
EU RoHS Directive	Pro-active compliance (Product out of EU RoHS legal scope) <a href="#">EU RoHS Declaration</a>
Mercury free	Yes
China RoHS Regulation	<a href="#">China RoHS declaration</a>
RoHS exemption information	Yes
Environmental Disclosure	<a href="#">Product Environmental Profile</a>

---

**Circularity Profile**[End of Life Information](#)

---

**WEEE**

The product must be disposed on European Union markets following specific waste collection and never end up in rubbish bins

---

**California proposition 65**

WARNING: This product can expose you to chemicals including: Lead and lead compounds, which is known to the State of California to cause cancer and birth defects or other reproductive harm. For more information go to [www.P65Warnings.ca.gov](http://www.P65Warnings.ca.gov)

---

**Contractual warranty**

---

**Warranty**

18 months

## Dimensions

---

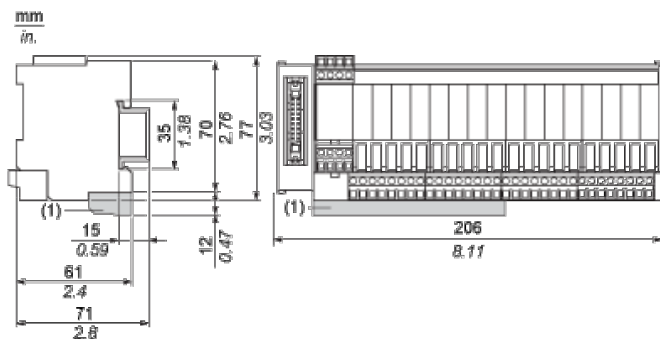

(1) ABE7BV20 / ABE7BV20E

Mounting

---

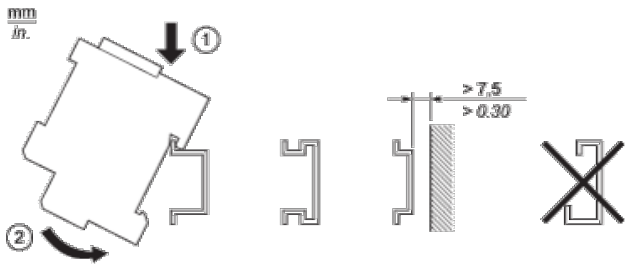

## HE10 16 Channels

---

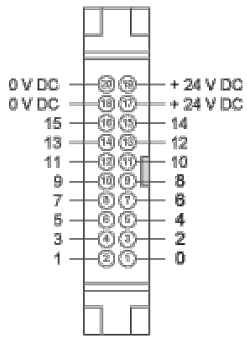

**Wiring Diagram**

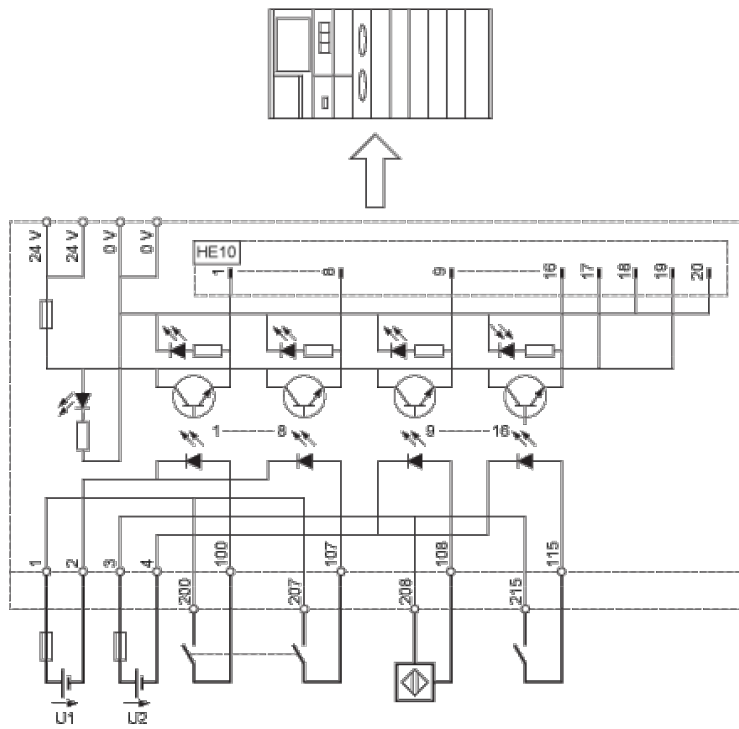

ABE7	U1, U2
S16E2B1 / E2B1E	24 VDC
S16E2E1 / E2E1E	48 VDC
S16E2E0 / E2E0E	48 VAC
S16E2F0 / E2F0E	115 VAC
S16E2M0 / E2M0E	230 VAC

**Curves for Determining Cable Type and Length According to the Current**

**16-channel Sub-base**

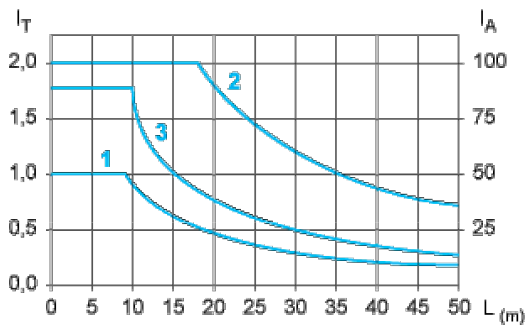

- L Cable length
- I<sub>T</sub> Total current per sub base (A)
- I<sub>A</sub> Average current per channel (mA)
- (1) TSXCDP••2 and ABFH20H••0 cables with c.s.a. 0.08 mm<sup>2</sup> (AWG 28).
- (2) TSXCDP••3 cables with c.s.a. 0.34 mm<sup>2</sup> (AWG 22).
- (3) Cables with c.s.a. 0.13 mm<sup>2</sup> (AWG 26).

The curves are given for a voltage drop of 1 V in the cable. For n volts tolerance, multiply the length determined from the graph by n.

**Recommended replacement(s)**