

- NOTES:
- PRECEDING ENG. NO. IN CHART DESIGNATES STANDARD PRODUCT.
 - SOLDERABILITY: WHEN PARTS ARE SOLDERED AT A TEMPERATURE OF 230°C (446°F) FOR 5 SECONDS, EACH SOLDERED SURFACE SHALL BE A MINIMUM OF 95% COVERED WITH A SMOOTH CONTINUOUS ADHERENT COATING. FOR OTHER INFORMATION SEE ES-152.
 - PIN PUSH OUT FORCE: PRIOR TO SOLDERING, A 3 POUND MINIMUM FORCE (IN EITHER DIRECTION) SHALL BE REQUIRED TO PUSH THE PIN OUT OF THE HEADER.
 - FOR ADDITIONAL INFORMATION AND TESTING PROCEDURES SEE PS-08-50.
 - PARTS ARE STACKABLE END TO END ON (3.96)/.156 CENTERS.
 - FOR PART WITH PEGS SEE DWG NO. SDA-42492
 - BURRS DUE TO CUTTING OFF OF PINS MUST NOT VARY FROM CENTERLINE OF PIN AT DATUM -D- BY MORE THAN .008 IN ANY DIRECTION.

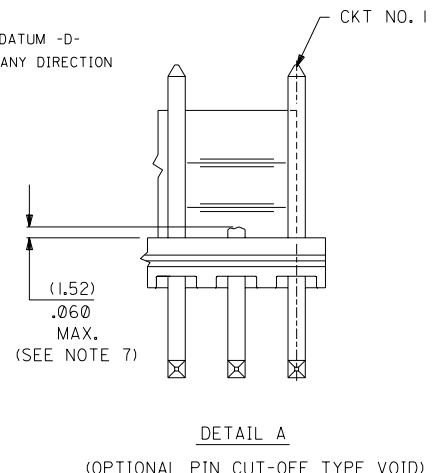

NO. OF CKT'S.	DIM. A	DIM. B
2	(3.96±.05) .156±.002	(7.77) .306
3	(7.92±.08) .312±.003	(11.73) .462
4	(11.89±.08) .468±.003	(15.70) .618
5	(15.85±.10) .624±.004	(19.66) .774
6	(19.81±.10) .780±.004	(23.62) .930
7	(23.77±.10) .936±.004	(27.58) 1.086
8	(27.74±.13) 1.092±.005	(31.55) 1.242
9	(31.70±.13) 1.248±.005	(35.51) 1.398
10	(35.66±.13) 1.404±.005	(39.47) 1.554
11	(39.62±.15) 1.560±.006	(43.43) 1.710
12	(43.59±.15) 1.716±.006	(47.40) 1.866
13	(47.55±.15) 1.872±.006	(51.36) 2.022
14	(51.51±.18) 2.028±.007	(55.32) 2.178
15	(55.47±.18) 2.184±.007	(59.28) 2.334
16	(59.44±.18) 2.340±.007	(63.25) 2.490
17	(63.40±.20) 2.496±.008	(67.21) 2.646
18	(67.36±.20) 2.652±.008	(71.17) 2.802

MATERIAL: HEADER: GLASS FILLED POLYESTER, 94V-0, MOLDED NATURAL (WHITE).
PIN: BRASS

PLATINGS:
(102) ELECTRO TIN .000450/.000200 OVER .000200/.000100 COPPER
(567) SELECT GOLD 15 M.I. MIN, SELECT TIN/LEAD 100 M.I. MIN., OVER NICKEL
(569) SELECT GOLD 30 M.I. MIN, SELECT TIN/LEAD 100 M.I. MIN., OVER NICKEL
FOR ADDITIONAL INFORMATION SE SDES-88.

REL SHT 5 UCP2003-0755 11/6/2002 SAMIEC	E2	DIMENSIONS SHOWN (METRIC) INCH UNLESS OTHERWISE SPECIFIED TOLERANCES: ANGULAR ± 1/2° <table border="1"> <tr><td>3 PLACE ±</td><td>INCH</td><td>METRIC</td></tr> <tr><td>2 PLACE ±</td><td></td><td></td></tr> <tr><td>1 PLACE ±</td><td></td><td></td></tr> </table> DRAFT WHERE APPLICABLE MUST REMAIN WITHIN DIMENSIONS DRWG. BY SAMIEC APP'D. BY LENZ CHK'D. BY PATEL SCALE:	3 PLACE ±	INCH	METRIC	2 PLACE ±			1 PLACE ±			DIMENSIONS SHOWN (METRIC) INCH UNLESS OTHERWISE SPECIFIED TOLERANCES: ANGULAR ± 1/2° <table border="1"> <tr><td>3 PLACE ±</td><td>INCH</td><td>METRIC</td></tr> <tr><td>2 PLACE ±</td><td></td><td></td></tr> <tr><td>1 PLACE ±</td><td></td><td></td></tr> </table> DRAFT WHERE APPLICABLE MUST REMAIN WITHIN DIMENSIONS DRWG. BY SAMIEC APP'D. BY LENZ CHK'D. BY PATEL SCALE:	3 PLACE ±	INCH	METRIC	2 PLACE ±			1 PLACE ±			TITLE: FRICTION LOCK HEADER ASS'Y .156 Q BENT SQ PINS, W/O PEGS 41792 SERIES DWG. MOLEX INCORPORATED LITSE, ILL. 60532 U.S.A. SHEET NO. 1 OF 6 DATE 09/09/87 PART NO. SDA-41792 DRWG. NO. SDA-41792 FILE NAME S41792X1 THIS DRAWING CONTAINS INFORMATION THAT IS PROPRIETARY TO MOLEX INC. AND SHOULD NOT BE USED WITHOUT WRITTEN PERMISSION. DIV. KK SIZE C
3 PLACE ±	INCH		METRIC																			
2 PLACE ±																						
1 PLACE ±																						
3 PLACE ±	INCH	METRIC																				
2 PLACE ±																						
1 PLACE ±																						
REL SHT 4 UCR2002-0555 12/17/01 SAMIEC	E1																					
ADD PACK SPEC UCR2002-0087 7/26/01 SAMIEC	E																					
REVISIONS	REVISIONS	MFG. SH. REV. <table border="1"> <tr><td>6</td><td>E</td></tr> <tr><td>5</td><td>E2</td></tr> <tr><td>4</td><td>E1</td></tr> <tr><td>3</td><td>E</td></tr> <tr><td>2</td><td>E</td></tr> <tr><td>1</td><td>E2</td></tr> </table>		6	E	5	E2	4	E1	3	E	2	E	1	E2							
6	E																					
5	E2																					
4	E1																					
3	E																					
2	E																					
1	E2																					

I3		I2		I1		I0		I9		I8		I7		I6		I5		I4		I3		I2		I1			
ENG. NO.		HEADER NO.		PIN NO.		PLATING		DIM. L		DIM. X		DIM. G GOLD		DIM. Y		DIM. Z		DIM. T TIN		DIM. W		NO OF CKTS		VOID CKTS		PACKAGING	
A-41792-0019/0035		41790-0002/0018		2161-37(501)		501		(27.94) 1.100		(11.43) .450		() OVERALL		(5.41) .213		(3.96) .156		() N/A		90°		2-18				BULK PER PK-41792-002	
A-41792-0036/0050		41790-0002/0018		2161-37(102)		102		(27.94) 1.100		(11.43) .450		() N/A		(5.41) .213		(3.96) .156		() OVERALL		90°		4-18		4		BULK PER PK-41792-002	
A-41792-0051/0067		41790-0002/0018		2161-64(102)		102		(29.85) 1.175		(13.28) .523		() N/A		(5.41) .213		(4.01) .158		() OVERALL		90°		2-18				BULK PER PK-41792-002	
A-41792-0068/0084		41790-0002/0018		2161-64(501)		501		(29.85) 1.175		(13.28) .523		() OVERALL		(5.41) .213		(4.01) .158		() N/A		90°		2-18				BULK PER PK-41792-002	
A-41792-0085/0101		41790-0002/0018		2161-64(503)		503		(29.85) 1.175		(13.28) .523		() OVERALL		(5.41) .213		(4.01) .158		() N/A		90°		2-18				BULK PER PK-41792-002	
A-41792-0102/0118		41790-0002/0018		2161-37(122)		122		(27.94) 1.100		(11.43) .450		() N/A		(5.41) .213		(3.96) .156		() OVERALL		90°		2-18				BULK PER PK-41792-002	

A-41792-0019/0035		A-41792-0036/0050				A-41792-0051/0067				A-41792-0068/0084				A-41792-0085/0101				A-41792-0102/0118			
EDP NO.	ENG. NO.	No OF CKTS	EDP NO.	ENG. NO.	No OF CKTS	EDP NO.	ENG. NO.	No OF CKTS	EDP NO.	ENG. NO.	No OF CKTS	EDP NO.	ENG. NO.	No OF CKTS	EDP NO.	ENG. NO.	No OF CKTS	EDP NO.	ENG. NO.	No OF CKTS	
26-61-5020	A-41792-0019	2			2	26-60-5021	A-41792-0051	2	26-61-5021	A-41792-0068	2			2	A-41792-0085	2	26-62-5022	A-41792-0102	2		
26-61-5030	A-41792-0020	3			3	26-60-5031	A-41792-0052	3	26-61-5031	A-41792-0069	3			3	A-41792-0086	3	26-62-5032	A-41792-0103	3		
26-61-5040	A-41792-0021	4	26-61-5043	A-41792-0036	4	26-60-5041	A-41792-0053	4	26-61-5041	A-41792-0070	4	26-61-5042	A-41792-0087	4	26-62-5042	A-41792-0104	4	26-62-5042	A-41792-0104	4	
26-61-5050	A-41792-0022	5	26-61-5053	A-41792-0037	5	26-60-5051	A-41792-0054	5	26-61-5051	A-41792-0071	5			5	A-41792-0088	5	26-62-5052	A-41792-0105	5		
26-61-5060	A-41792-0023	6	26-61-5063	A-41792-0038	6	26-60-5061	A-41792-0055	6	26-61-5061	A-41792-0072	6	26-61-5062	A-41792-0089	6	26-62-5062	A-41792-0106	6	26-62-5062	A-41792-0106	6	
26-61-5070	A-41792-0024	7	26-61-5073	A-41792-0039	7	26-60-5071	A-41792-0056	7	26-61-5071	A-41792-0073	7			7	A-41792-0090	7	26-62-5072	A-41792-0107	7		
26-61-5080	A-41792-0025	8	26-61-5083	A-41792-0040	8	26-60-5081	A-41792-0057	8	26-61-5081	A-41792-0074	8	26-61-5082	A-41792-0091	8	26-62-5082	A-41792-0108	8	26-62-5082	A-41792-0108	8	
26-61-5090	A-41792-0026	9	26-61-5093	A-41792-0041	9	26-60-5091	A-41792-0058	9	26-61-5091	A-41792-0075	9			9	A-41792-0092	9	26-62-5092	A-41792-0109	9		
26-61-5100	A-41792-0027	10	26-61-5103	A-41792-0042	10	26-60-5101	A-41792-0059	10	26-61-5101	A-41792-0076	10	26-61-5102	A-41792-0093	10	26-62-5102	A-41792-0110	10	26-62-5102	A-41792-0110	10	
26-61-5110	A-41792-0028	11	26-61-5113	A-41792-0043	11	26-60-5111	A-41792-0060	11	26-61-5111	A-41792-0077	11			11	A-41792-0094	11	26-62-5112	A-41792-0111	11		
26-61-5120	A-41792-0029	12	26-61-5123	A-41792-0044	12	26-60-5121	A-41792-0061	12	26-61-5121	A-41792-0078	12	26-61-5122	A-41792-0095	12	26-62-5122	A-41792-0112	12	26-62-5122	A-41792-0112	12	
26-61-5130	A-41792-0030	13	26-61-5133	A-41792-0045	13	26-60-5131	A-41792-0062	13	26-61-5131	A-41792-0079	13			13	A-41792-0096	13	26-62-5132	A-41792-0113	13		
26-61-5140	A-41792-0031	14	26-61-5143	A-41792-0046	14	26-60-5141	A-41792-0063	14	26-61-5141	A-41792-0080	14			14	A-41792-0097	14	26-62-5142	A-41792-0114	14		
26-61-5150	A-41792-0032	15	26-61-5153	A-41792-0047	15	26-60-5151	A-41792-0064	15	26-61-5151	A-41792-0081	15			15	A-41792-0098	15	26-62-5152	A-41792-0115	15		
26-61-5160	A-41792-0033	16	26-61-5163	A-41792-0048	16	26-60-5161	A-41792-0065	16	26-61-5161	A-41792-0082	16			16	A-41792-0099	16	26-62-5162	A-41792-0116	16		
26-61-5170	A-41792-0034	17	26-61-5173	A-41792-0049	17	26-60-5171	A-41792-0066	17	26-61-5171	A-41792-0083	17			17	A-41792-0100	17	26-62-5172	A-41792-0117	17		
26-61-5180	A-41792-0035	18	26-61-5183	A-41792-0050	18	26-60-5181	A-41792-0067	18	26-61-5181	A-41792-0084	18			18	A-41792-0101	18	26-62-5182	A-41792-0118	18		

A-41792-0019/0035		A-41792-0036/0050				A-41792-0051/0067				A-41792-0068/0084				A-41792-0085/0101				A-41792-0102/0118			
EDP NO.	ENG. NO.	No OF CKTS	EDP NO.	ENG. NO.	No OF CKTS	EDP NO.	ENG. NO.	No OF CKTS	EDP NO.	ENG. NO.	No OF CKTS	EDP NO.	ENG. NO.	No OF CKTS	EDP NO.	ENG. NO.	No OF CKTS	EDP NO.	ENG. NO.	No OF CKTS	
26-61-5020	A-41792-0019	2			2	26-60-5021	A-41792-0051	2	26-61-5021	A-41792-0068	2			2	A-41792-0085	2	26-62-5022	A-41792-0102	2		
26-61-5030	A-41792-0020	3			3	26-60-5031	A-41792-0052	3	26-61-5031	A-41792-0069	3			3	A-41792-0086	3	26-62-5032	A-41792-0103	3		
26-61-5040	A-41792-0021	4	26-61-5043	A-41792-0036	4	26-60-5041	A-41792-0053	4	26-61-5041	A-41792-0070	4	26-61-5042	A-41792-0087	4	26-62-5042	A-41792-0104	4	26-62-5042	A-41792-0104	4	
26-61-5050	A-41792-0022	5	26-61-5053	A-41792-0037	5	26-60-5051	A-41792-0054	5	26-61-5051	A-41792-0071	5			5	A-41792-0088	5	26-62-5052	A-41792-0105	5		
26-61-5060	A-41792-0023	6	26-61-5063	A-41792-0038	6	26-60-5061	A-41792-0055	6	26-61-5061	A-41792-0072	6	26-61-5062	A-41792-0089	6	26-62-5062	A-41792-0106	6	26-62-5062	A-41792-0106	6	
26-61-5070	A-41792-0024	7	26-61-5073	A-41792-0039	7	26-60-5071	A-41792-0056	7	26-61-5071	A-41792-0073	7			7	A-41792-0090	7	26-62-5072	A-41792-0107	7		
26-61-5080	A-41792-0025	8	26-61-5083	A-41792-0040	8	26-60-5081	A-41792-0057	8	26-61-5081	A-41792-0074	8	26-61-5082	A-41792-0091	8	26-62-5082	A-41792-0108	8	26-62-5082	A-41792-0108	8	
26-61-5090	A-41792-0026	9	26-61-5093	A-41792-0041	9	26-60-5091	A-41792-0058	9	26-61-5091	A-41792-0075	9			9	A-41792-0092	9	26-62-5092	A-41792-0109	9		
26-61-5100	A-41792-0027	10	26-61-5103	A-41792-0042	10	26-60-5101	A-41792-0059	10	26-61-5101	A-41792-0076	10	26-61-5102	A-41792-0093	10	26-62-5102	A-41792-0110	10	26-62-5102	A-41792-0110	10	
26-61-5110	A-41792-0028	11	26-61-5113	A-41792-0043	11	26-60-5111	A-41792-0060	11	26-61-5111	A-41792-0077	11			11	A-41792-0094	11	26-62-5112	A-41792-0111	11		
26-61-5120	A-41792-0029	12	26-61-5123	A-41792-0044	12	26-60-5121	A-41792-0061	12	26-61-5121	A-41792-0078	12	26-61-5122	A-41792-0095	12	26-62-5122	A-41792-0112	12	26-62-5122	A-41792-0112	12	
26-61-5130	A-41792-0030	13	26-61-5133	A-41792-0045	13	26-60-5131	A-41792-0062	13	26-61-5131	A-41792-0079	13			13	A-41792-0096	13	26-62-5132	A-41792-0113	13		
26-61-5140	A-41792-0031	14	26-61-5143	A-41792-0046	14	26-60-5141	A-41792-0063	14	26-61-5141	A-41792-0080	14			14	A-41792-0097	14	26-62-5142	A-41792-0114	14		
26-61-5150	A-41792-0032	15	26-61-5153	A-41792-0047	15	26-60-5151	A-41792-0064	15	26-61-5151	A-41792-0081	15			15	A-41792-0098	15	26-62-5152	A-41792-0115	15		
26-61-5160	A-41792-0033	16	26-61-5163	A-41792-0048	16	26-60-5161	A-41792-0065	16	26-61-5161	A-41792-0082	16			16	A-41792-0099	16	26-62-5162	A-41792-0116	16		
26-61-5170	A-41792-0034	17	26-61-5173	A-41792-0049	17	26-60-5171	A-41792-0066	17	26-61-5171	A-41792-0083	17			17	A-41792-0100	17	26-62-5172	A-41792-0117	17		
26-61-5180	A-41792-0035	18	26-61-5183	A-41792-0050	18	26-60-5181	A-41792-0067	18	26-61-5181	A-41792-0084	18			18	A-41792-0101	18	26-62-5182	A-41792-0118	18		

SEE SHEET I	SEE SHEET I	SEE SHEET I	SEE SHEET I	SEE SHEET I	SEE SHEET I	SEE SHEET I	SEE SHEET I	SEE SHEET I	SEE SHEET I	SEE SHEET I	SEE SHEET I	SEE SHEET I	SEE SHEET I	SEE SHEET I	SEE SHEET I	SEE SHEET I	SEE SHEET I	SEE SHEET I	SEE SHEET I	SEE SHEET I	SEE SHEET I	SEE SHEET I	SEE SHEET I	SEE SHEET I	
LTR.	REVISIONS	LTR.	REVISIONS	LTR.	REVISIONS	LTR.	REVISIONS	LTR.	REVISIONS	LTR.	REVISIONS	LTR.	REVISIONS	LTR.	REVISIONS	LTR.	REVISIONS	LTR.	REVISIONS	LTR.	REVISIONS	LTR.	REVISIONS	LTR.	REVISIONS
DIMENSIONS SHOWN (METRIC) INCH UNLESS OTHERWISE SPECIFIED TOLERANCES ANGULAR ± 1/2°												REVISIONS 3 PLACE ± 2 PLACE ± 1 PLACE ±				DRAFT WHERE APPLICABLE MUST REMAIN WITHIN DIMENSIONS DRWG. NO. SDA-41792									
DRWG. BY: SAMEIC CHK'D. BY: PATEL APP'D. BY: LENZ												TITLE: FRICTION LOCK HEADER ASSY .156 @ BENT SQ PINS, W/O PEGS 41792 SERIES DWG				MOLEX INCORPORATED 1151E.JLL.									