

REVISIONS					
REV	ECO	DESCRIPTION	DATE	BY	APPR
B1	-	RELEASED DRAWING	JAN-18-2014	ARROW	TOMMY
B2	-	CHANGE DIMENSION TOLERANCE	FEB-3-2015	ARROW	TOMMY
B3	-	DESIGN CHANGE	MAR-30-2015	BEN	TOMMY
B4	-	DESIGN CHANGE	JUL-18-2017	FLAN	TOMMY
B5	-	Update drawing	Jun-21-18	Flan	Tommy

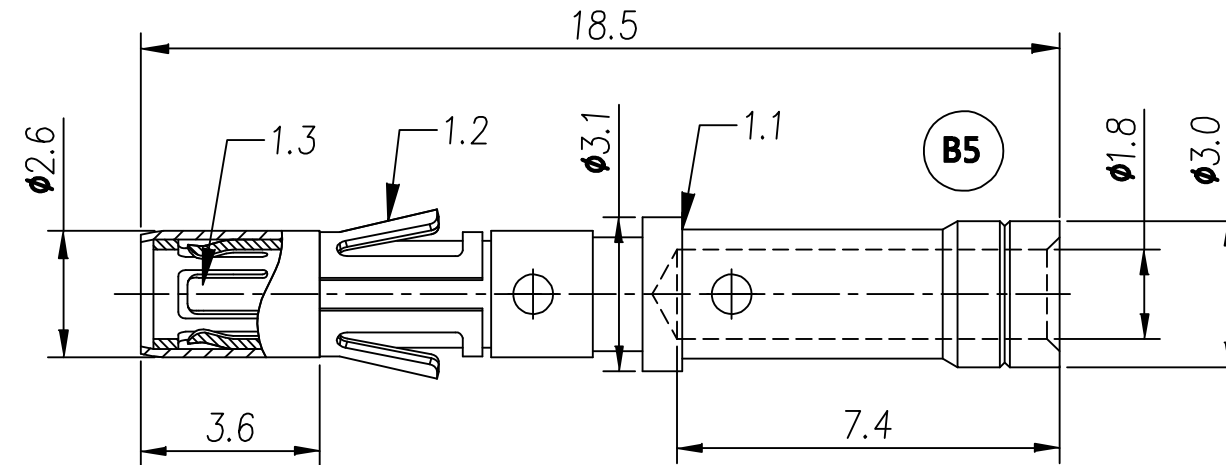

**NOTES : ( UNLESS OTHERWISE SPECIFIED )**

**1. MATERIAL :**

- 1.1. CONTACT BODY : COPPER ALLOY.
- 1.2. POSITIONING CLIP : COPPER ALLOY.
- 1.3. CROWN CONTACT : COPPER ALLOY.

**2. SPECIFICATIONS :**

- 2.1 CURRENT RATING : 13A(MAX).
- 2.2 TERMINATION TYPE : CRIMPING.
- 2.3 WIRE RANGE : 16~18AWG.

**3. SUITABLE CONTACT : MP16M23xx.**

**4. RoHS COMPLIANT.**

**5. ALL DIMENSIONS ARE FOR REFERENCE USE ONLY.**

P/N	CONTACT PLATING(MATING AREA)
MS16M23T	TIN PLATING OVER NICKEL.
MS16M23S	SILVER PLATING OVER NICKEL.
MS16M23F	GOLD FLASH PLATING OVER NICKEL.
MS16M23G5	5 $\mu$ "GOLD PLATING OVER NICKEL.
MS16M23G10	10 $\mu$ "GOLD PLATING OVER NICKEL.
MS16M23G15	15 $\mu$ "GOLD PLATING OVER NICKEL.
MS16M23G30	30 $\mu$ "GOLD PLATING OVER NICKEL.

QUANTITY	PART NUMBER	DESCRIPTION	ITEM
<b>MATERIALS LIST</b>			
<b>UNLESS OTHERWISE SPECIFIED</b> 1) All dimensions are in metric(mm). 2) Tolerances are as follows: 1 PL DEC $\pm 0.30$ 2 PL DEC $\pm 0.15$ 3 PL DEC $\pm 0.08$ 3) Note reference =		<b>SIGNATURES</b> DRAWN: Flan CHECKED: Tod ENGINEER: APPROVAL: Tommy DATE: Jun-21-18 Jun-21-18 Jun-21-18	<b>Amphenol</b> Sine Systems - www.amphenol-sine.com 44724 Morley Drive Clinton Township, MI 48036
<b>MATERIAL SPECIFICATIONS:</b>		<b>CUSTOMER:</b> ECO-MATE, SOCKET CONTACT MACHINE, 16-18AWG, SIZE 16	<b>SIZE</b> B <b>TYPE</b> C- <b>DWG NO:</b> MS16M23xx <b>REVISION</b> B5
<b>PROCESS SPECIFICATIONS:</b>		THIS DRAWING IS SUPPLIED FOR INFORMATION ONLY. DESIGN FEATURES, SPECIFICATIONS AND PERFORMANCE DATA SHOWN HEREON ARE THE PROPERTY OF THE AMPHENOL CORPORATION. NO RIGHTS OF REPRODUCTION ARE IMPLIED. ALL DIMENSIONS ARE SUBJECT TO NORMAL MANUFACTURING VARIATIONS.	<b>SCALE:</b> NONE <b>SHEET</b> 1 <b>OF</b> 1
<b>NEXT ASSY:</b>			

TITLE: ECO-MATE SOCKET CONTACT MACHINE, 16-18AWG, SIZE 16  
 DWG NO: MS16M23xx  
 REV: B5  
 SH: 1  
 OF: 1