



**MICROCHIP**

---

**mTouch™ AR1100  
Analog Resistive USB and RS-232  
Touch Screen Controller Board  
User's Guide**

---

---

**Note the following details of the code protection feature on Microchip devices:**

- Microchip products meet the specification contained in their particular Microchip Data Sheet.
- Microchip believes that its family of products is one of the most secure families of its kind on the market today, when used in the intended manner and under normal conditions.
- There are dishonest and possibly illegal methods used to breach the code protection feature. All of these methods, to our knowledge, require using the Microchip products in a manner outside the operating specifications contained in Microchip's Data Sheets. Most likely, the person doing so is engaged in theft of intellectual property.
- Microchip is willing to work with the customer who is concerned about the integrity of their code.
- Neither Microchip nor any other semiconductor manufacturer can guarantee the security of their code. Code protection does not mean that we are guaranteeing the product as "unbreakable."

Code protection is constantly evolving. We at Microchip are committed to continuously improving the code protection features of our products. Attempts to break Microchip's code protection feature may be a violation of the Digital Millennium Copyright Act. If such acts allow unauthorized access to your software or other copyrighted work, you may have a right to sue for relief under that Act.

---

Information contained in this publication regarding device applications and the like is provided only for your convenience and may be superseded by updates. It is your responsibility to ensure that your application meets with your specifications. MICROCHIP MAKES NO REPRESENTATIONS OR WARRANTIES OF ANY KIND WHETHER EXPRESS OR IMPLIED, WRITTEN OR ORAL, STATUTORY OR OTHERWISE, RELATED TO THE INFORMATION, INCLUDING BUT NOT LIMITED TO ITS CONDITION, QUALITY, PERFORMANCE, MERCHANTABILITY OR FITNESS FOR PURPOSE. Microchip disclaims all liability arising from this information and its use. Use of Microchip devices in life support and/or safety applications is entirely at the buyer's risk, and the buyer agrees to defend, indemnify and hold harmless Microchip from any and all damages, claims, suits, or expenses resulting from such use. No licenses are conveyed, implicitly or otherwise, under any Microchip intellectual property rights.

**Trademarks**

The Microchip name and logo, the Microchip logo, dsPIC, KEELOQ, KEELOQ logo, MPLAB, PIC, PICmicro, PICSTART, PIC<sup>32</sup> logo, rfPIC and UNI/O are registered trademarks of Microchip Technology Incorporated in the U.S.A. and other countries.

FilterLab, Hampshire, HI-TECH C, Linear Active Thermistor, MXDEV, MXLAB, SEEVAL and The Embedded Control Solutions Company are registered trademarks of Microchip Technology Incorporated in the U.S.A.

Analog-for-the-Digital Age, Application Maestro, chipKIT, chipKIT logo, CodeGuard, dsPICDEM, dsPICDEM.net, dsPICworks, dsSPEAK, ECAN, ECONOMONITOR, FanSense, HI-TIDE, In-Circuit Serial Programming, ICSP, Mindi, MiWi, MPASM, MPLAB Certified logo, MPLIB, MPLINK, mTouch, Omniscient Code Generation, PICC, PICC-18, PICDEM, PICDEM.net, PCKit, PICtail, REAL ICE, rfLAB, Select Mode, Total Endurance, TSHARC, UniWinDriver, WiperLock and ZENA are trademarks of Microchip Technology Incorporated in the U.S.A. and other countries.

SQTP is a service mark of Microchip Technology Incorporated in the U.S.A.

All other trademarks mentioned herein are property of their respective companies.

© 2011, Microchip Technology Incorporated, Printed in the U.S.A., All Rights Reserved.

 Printed on recycled paper.

ISBN: 978-1-61341-491-0

**QUALITY MANAGEMENT SYSTEM**  
**CERTIFIED BY DNV**  
**== ISO/TS 16949:2009 ==**

*Microchip received ISO/TS-16949:2009 certification for its worldwide headquarters, design and wafer fabrication facilities in Chandler and Tempe, Arizona; Gresham, Oregon and design centers in California and India. The Company's quality system processes and procedures are for its PIC<sup>®</sup> MCUs and dsPIC<sup>®</sup> DSCs, KEELOQ<sup>®</sup> code hopping devices, Serial EEPROMs, microperipherals, nonvolatile memory and analog products. In addition, Microchip's quality system for the design and manufacture of development systems is ISO 9001:2000 certified.*



# mTouch™ AR1100 User's Guide

---

---

## Table of Contents

---

---

<b>Preface</b> .....	<b>5</b>
Introduction.....	5
Document Layout .....	6
Recommended Reading.....	6
The Microchip Web Site .....	6
Customer Support .....	7
Document Revision History .....	7
<b>Chapter 1. Product Overview</b>	
1.1 Introduction .....	9
1.2 Product Description .....	9
<b>Chapter 2. Connections</b>	
2.1 Mounting .....	13
2.2 Power .....	13
2.3 Communication .....	14
2.4 Sensor .....	16
<b>Chapter 3. Operation</b>	
3.1 Configuration .....	19
3.2 Communication .....	19
3.3 Data Format .....	19
3.4 LED Indicator .....	21
<b>Chapter 4. Software Device Drivers</b>	
<b>Chapter 5. Accessories</b>	
5.1 Communication Cables .....	25
5.2 Touch Screen Cables .....	25
<b>Chapter 6. Support</b>	
<b>Chapter 7. Touch Screen Selection</b>	
<b>Index</b> .....	<b>31</b>
<b>Worldwide Sales and Service</b> .....	<b>32</b>

# mTouch™ AR1100 User's Guide

---

NOTES:



# mTouch™ AR1100 User's Guide

## Preface

### NOTICE TO CUSTOMERS

All documentation becomes dated, and this manual is no exception. Microchip tools and documentation are constantly evolving to meet customer needs, so some actual dialogs and/or tool descriptions may differ from those in this document. Please refer to our web site ([www.microchip.com](http://www.microchip.com)) to obtain the latest documentation available.

Documents are identified with a "DS" number. This number is located on the bottom of each page, in front of the page number. The numbering convention for the DS number is "DSXXXXA", where "XXXX" is the document number and "A" is the revision level of the document.

For the most up-to-date information on development tools, see the MPLAB® IDE on-line help. Select the Help menu, and then Topics to open a list of available online help files.

## INTRODUCTION

This chapter contains the general information that will be useful to know before using the mTouch™ AR1100 Analog Resistive USB and RS-232 Touch Screen Controller Board. Items discussed in this chapter include:

- Document Layout
- Recommended Reading
- The Microchip Web Site
- Customer Support
- Document Revision History

# mTouch™ AR1100 User's Guide

---

## DOCUMENT LAYOUT

This document describes how to use the mTouch™ AR1100 Analog Resistive USB and RS-232 Touch Screen Controller Board. The manual layout is as follows:

- [Chapter 1. “Product Overview”](#)
- [Chapter 2. “Connections”](#)
- [Chapter 3. “Operation”](#)
- [Chapter 4. “Software Device Drivers”](#)
- [Chapter 5. “Accessories”](#)
- [Chapter 6. “Support”](#)
- [Chapter 7. “Touch Screen Selection”](#)

## RECOMMENDED READING

This user's guide describes how to use the mTouch™ AR1100 Analog Resistive USB and RS-232 Touch Screen Controller Board. Other useful documents are listed below. The following Microchip documents are available and recommended as supplemental reference resources.

### **Readme for mTouch™ AR1100 Analog Resistive USB and RS-232 Touch Screen Controller Board**

For the latest information on using mTouch™ AR1100 Analog Resistive USB and RS-232 Touch Screen Controller Board, read the “`Readme.txt`” file in the main installation directory. The Readme file contains updated information and known issues that may not be included in this user's guide.

### **Readme Files**

For the latest information on using other tools, read the tool-specific Readme files in the Readme subdirectory of the MPLAB IDE installation directory. The Readme files contain update information and known issues that may not be included in this user's guide.

## THE MICROCHIP WEB SITE

Microchip provides online support through our web site at [www.microchip.com](http://www.microchip.com). This web site is used as a means to make files and information easily available to customers. Accessible by using your favorite Internet browser, the web site contains the following information:

- **Product Support** – Data sheets and errata, application notes and sample programs, design resources, user's guides and hardware support documents, latest software releases and archived software
- **General Technical Support** – Frequently Asked Questions (FAQs), technical support requests, online discussion groups, Microchip consultant program member listing
- **Business of Microchip** – Product selector and ordering guides, latest Microchip press releases, listing of seminars and events, listings of Microchip sales offices, distributors and factory representatives

## CUSTOMER SUPPORT

Users of Microchip products can receive assistance through several channels:

- Distributor or Representative
- Local Sales Office
- Field Application Engineer (FAE)
- Technical Support

Customers should contact their distributor, representative or field application engineer (FAE) for support. Local sales offices are also available to help customers. A listing of sales offices and locations is included in the back of this document.

Technical support is available through the web site at: <http://support.microchip.com>

## DOCUMENT REVISION HISTORY

### Revision A (August 2011)

Initial release of this document.

# mTouch™ AR1100 User's Guide

---

NOTES:



---

---

## Chapter 1. Product Overview

---

---

### 1.1 INTRODUCTION

The Microchip mTouch™ AR1100 Analog Resistive USB and RS-232 Touch Screen Controller Board represents a feature-rich, fully-integrated universal touch screen controller solution. The AR1100 Touch Screen Controller Board automatically selects between USB and RS-232 communication protocols, as well as supports 4, 5 or 8-wire analog resistive touch screens from any of a variety of touch screen manufacturers. The AR1100 Touch Screen Controller Board dynamically adapts to the various touch screen electrical characteristics such as sensitivity, contact resistance, and capacitance to provide optimal performance with minimal design time.

Building on the AR1000 series, the new AR1100 Touch Screen Controller Board offers customers an easy to integrate solution for low-cost, high-performing resistive touch with the advantages of USB plug and play, support for USB mouse or digitizer, advanced touch response and accuracy, field-flash updatability, and free drivers for most operating systems to enable low-risk designs for a wide variety of touch sensing requirements.

The AR1100 Touch Screen Controller Board supports large displays like industrial controls, self-service kiosks, and POS terminals, as well as smaller tablet displays, hand-held consumer devices, and medical devices.

Resistive touch provides the advantages of easy integration, low total system cost and acceptance of finger, glove or stylus input, and USB communication is the industry standard for attaching peripherals to a computer. The AR1100 Touch Screen Controller Board is an easy-to-integrate touch screen controller that meets all of these needs in a single-chip solution or production ready-board product. The device comes with free drivers for most major operating systems, making it easy for designers to quickly create low-risk touch interface solutions.

### 1.2 PRODUCT DESCRIPTION

The mTouch™ AR1100 Touch Screen Controller Board auto-detects communication (RS-232 or USB) and uses a jumper to select between 5-wire and 4/8-wire analog resistive touch screens. The AR1100 Touch Screen Controller Board is ready to go out of the box with little or no configuration.

#### 1.2.1 Part Number

AR1100BRD

#### 1.2.2 AR1100 Core Features:

- RoHS Compliant
- Automatically detects communication type
  - RS-232 (9600 BAUD) and USB (2.0 Compliant)
  - Full-speed USB device HID compliant at 12 Mb/sec.
  - Low-power Suspend mode for USB < 500 uA
  - Low-power Sleep mode for RS-232 <10 uA

# mTouch™ AR1100 User's Guide

- USB plug and play
  - USB mouse (HID-MOUSE) or
  - Single-touch Win7 digitizer (HID-DIGITIZER)
- Jumper-selectable sensor support
  - 5 wire
  - 4/8 wire
- Dynamic rise-time and sampling capability
- Resolution:
  - 10-bit measurement (1024x1024)
  - 12-bit reporting (4096x4096) of processed touch coordinates
  - Report rate: 150 rps (typical)
  - Touch screen resistance – 2k ohm sheet resistance lead to lead.
  - Calibration data stored on local EEPROM
  - User EEPROM available – 96 bytes
  - Flash/Data EEPROM retention: >40 years
  - Industry-leading touch response and accuracy
  - ESD protection – both communication and touch screen connections
- Static Protection: 24 kVA

## 1.2.3 Mechanical

### 1.2.3.1 DIMENSIONS

FIGURE 1-1: PCB – MECHANICAL DRAWING

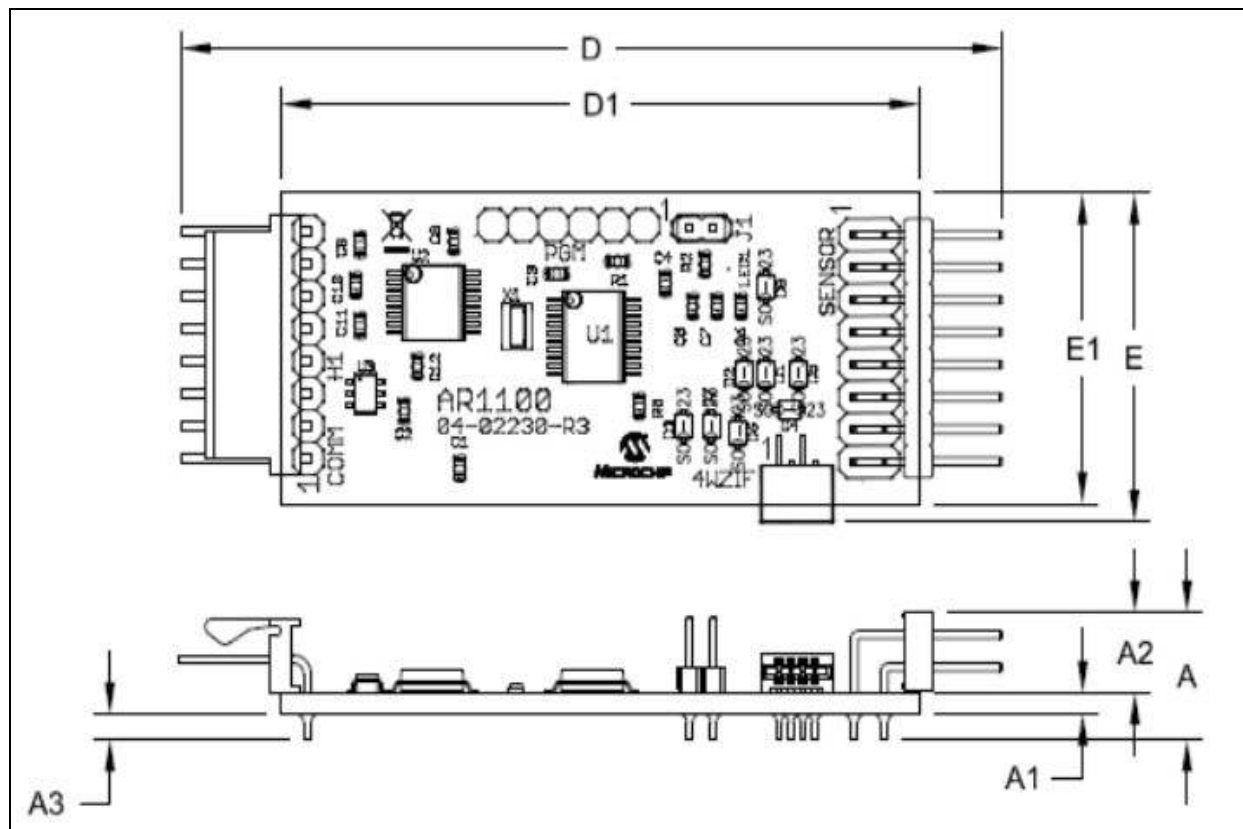

**TABLE 1-1: PCB – MECHANICAL DIMENSIONS**

Units:		Millimeters			Inches		
Dimension Limits:		MIN.	NOM.	MAX.	MIN.	NOM.	MAX.
Overall Length	D	67.51	69.02	70.56	2.658	2.718	2.778
Overall Width	E	24.28	25.81	27.33	0.956	1.016	1.076
PCB Length	D1	52.07	53.59	55.12	2.050	2.110	2.17
PCB Width	E1	2.29	24.38	25.91	0.090	0.960	1.02
Overall Height	A	—	—	11.63	—	—	0.458
PCB Thickness	A1	1.42	15.75	1.73	0.056	0.620	0.068
Component Height	A2	—	6.35	7.87	—	0.250	0.310
Through Hole Lead Trim Length	A3	—	—	2.03	—	—	0.080

**Note 1:** Passive components omitted from some views for clarity.

**2:** Dimensions and tolerances per ASME Y14.5M.

BSC: Basic Dimension. Theoretically exact value shown without tolerances.

REF: Reference Dimension, usually without tolerance, for information purposes only.

## WARNING

Although Microchip Technology Inc. has taken steps to protect your touch screen controller from transient voltage, it is important to make all grounding, communication and touch screen connections to the controller and touch screen. This must be done before powering on your computer, video monitor or touch screen controller. Failure to follow this procedure may result in damage to your controller and/or communication port. If you believe that your application will require additional static protection, it is up to you to determine the appropriate static protection needed to protect your electronics from transient voltage.

**Failure to take the necessary precautions may result in damage to your controller. Microchip does not warranty the Microchip controller board against transient static discharge damage.**

## 1.2.4 Electrical

**TABLE 1-2: PCB – ELECTRICAL SPECIFICATIONS**

	Conditions	Min.	Typical	Max.	Units
Supply Voltage		3.3		5.0	V
Supply Current	RS-232 (idle)		16		mA
	RS-232 (touch)		18		
	USB (idle)		17		
	USB (touch)		25		
Suspend Current	RS232			10	μA
	USB			330	
Operating temperature	Chip	-40		125	°C
	Board	-25		85	°C
Resolution	VCC: +5V, VDD: Gnd		1024 x 1024		Pixels
Response Time	Normal		8		ms
	Waking		10		
Detect Voltage Threshold			1.65		V
Touch Screen Resistance				2000	Ω
Touch Capacitance		0		0.5	μF

**Note 1:** Additional literature is available from Microchip Technology Inc. – definitions, specifications, and other general touch screen information.

**Chapter 2. Connections**

**FIGURE 2-1: CONNECTIONS – OVERVIEW**

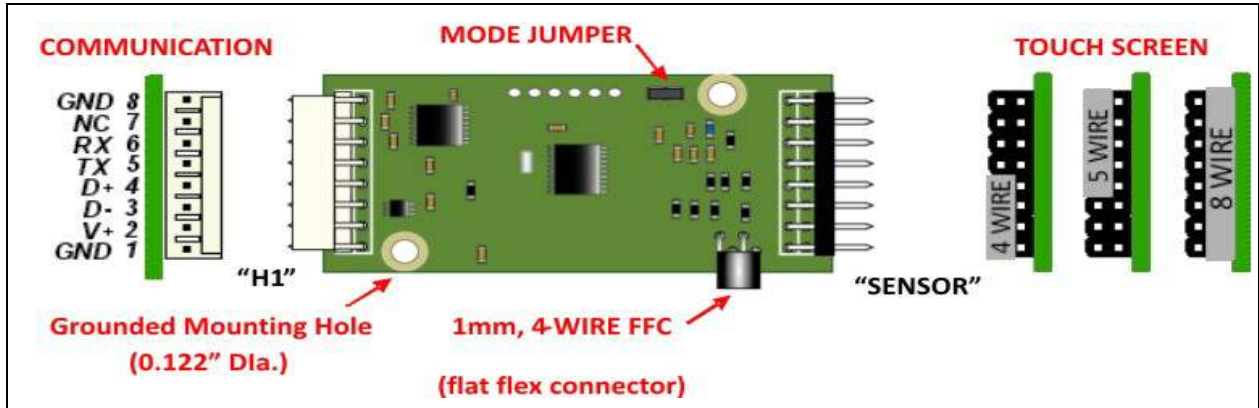

**2.1 MOUNTING**

Two static ground mounting holes (0.122" diameter) are provided. Take special care to insulate the controller from system and from EMI and RFI generating components of the display. Use conductive 4-40 stand-offs or ground-lead wires terminated to the grounded system enclosure or PC board to insure proper static protection and grounding. *STANDOFFS MUST NOT TOUCH ANY PORTION OF THE CIRCUIT.*

Position the controller in a location that minimizes bending or creasing of the touch screen overlay connection tail. Wear to the tail, printed traces, or tail header will negatively impact touch screen performance.

**2.2 POWER**

Power to the AR1100 Touch Screen Controller Board is provided by the H1 communication connector as seen in Figure 2-2. In USB Communication mode, power can be derived from the USB bus. In RS-232 mode – regulated power (3.3V – 5.0V) is provided from an external source. Check connections before applying power to the controller as **reversing polarity WILL damage the board.**

**FIGURE 2-2: POWER**

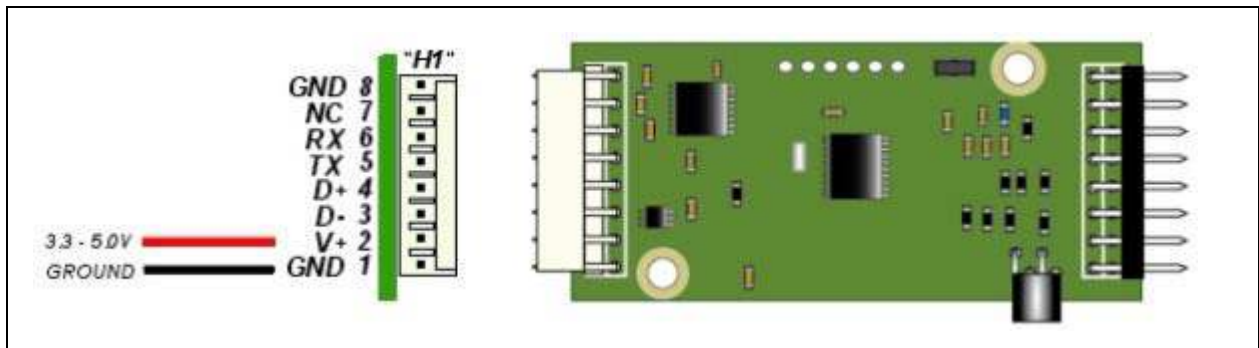

## WARNING

SUPPLYING POWER FROM TWO DIFFERENT POWER SOURCES WILL PERMANENTLY DESTROY YOUR CONTROLLER, YOUR COMPUTER, OR YOUR MONITOR.

If the Microchip AR1100 Touch Screen Controller Board is installed into a monitor application where the end user will decide to use USB communication or RS-232 communication, the board must be powered internally. Because the board cannot be supplied with power from USB and internal 5V, it is recommended that the power (pin 1) contact be removed from the USB socket to insure that multiple power source connections are not permitted.

## 2.3 COMMUNICATION

The AR1100 Touch Screen Controller Board will automatically detect and configure itself for the active communication protocol – RS-232 or USB HID. The controller will default to RS-232 communication until USB activity is detected. Once the active communication mode is determined, the inactive mode is decommissioned to minimize power consumption. The active communication will remain in effect until power is removed from the controller.

### 2.3.1 RS-232

Microchip cable harness p/n: C72-080S1F-09XDXF is a standard 6' long, round shielded cable terminated by a DB-9 female connector and an 8-position single-row socket. This cable has a ground termination wire running the length of the cable which may be utilized to ground the controller board through the DB-9 connector. In any case, for best performance, a jacketed, shielded cable is recommended.

FIGURE 2-3: RS-232 CONNECTIONS

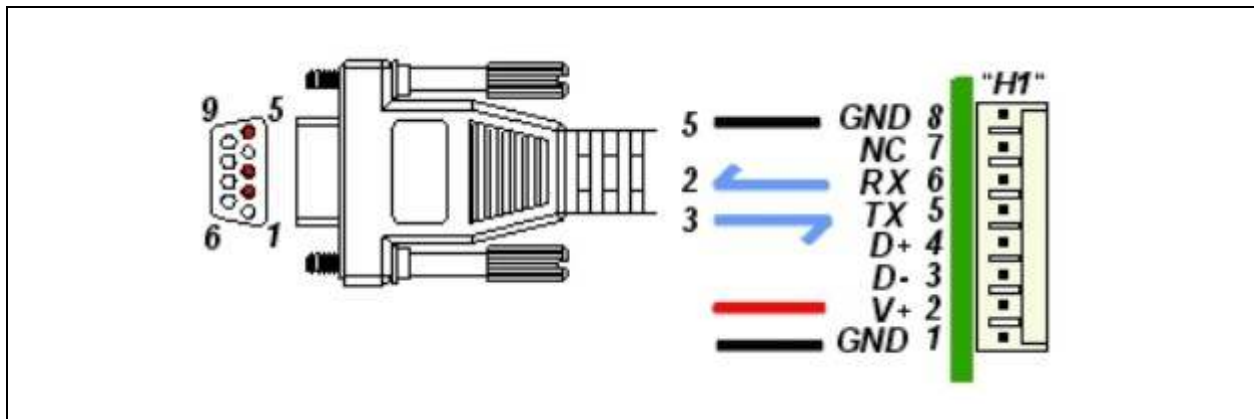

## 2.3.2 USB

Microchip cable harness p/n: C72-080S1F-04XAXM-D is a 6' long, jacketed shielded cable terminated by a Type "A" USB plug and an 8-position, single-row socket. *DO NOT SUPPLY POWER FROM BOTH RS-232 AND USB.*

FIGURE 2-4: USB

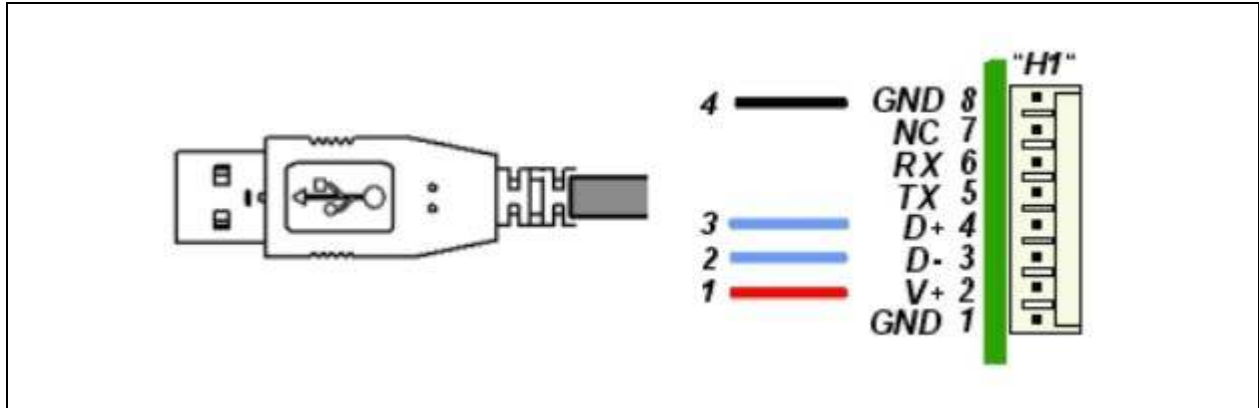

### WARNING

SUPPLYING POWER FROM TWO DIFFERENT POWER SOURCES COULD PERMANENTLY DAMAGE YOUR CONTROLLER, YOUR COMPUTER, AND/OR YOUR MONITOR.

If the Microchip AR1100 Touch Screen Controller Board is installed into a monitor application where the end user will decide to use USB communication or RS-232 communication, the board must be powered internally. Because the board cannot be supplied with power from USB and internal 5V, it is recommended that the power (pin 1) contact be removed from the USB socket to insure that multiple power source connections are not permitted.

# mTouch™ AR1100 User's Guide

## 2.4 SENSOR

The AR1100 Touch Screen Controller Board supports 4, 5 and 8-wire sensors. A 2x8 pin header (“SENSOR”) seen in the mechanical diagram is the connection point for all 3 sensor types. Additionally, a 4-conductor flat flex connector can be used with 4-wire sensors. An illustration of sensor wiring/construction is given below for reference (see Figure 2-5).

**FIGURE 2-5: SENSOR CONNECTIONS**

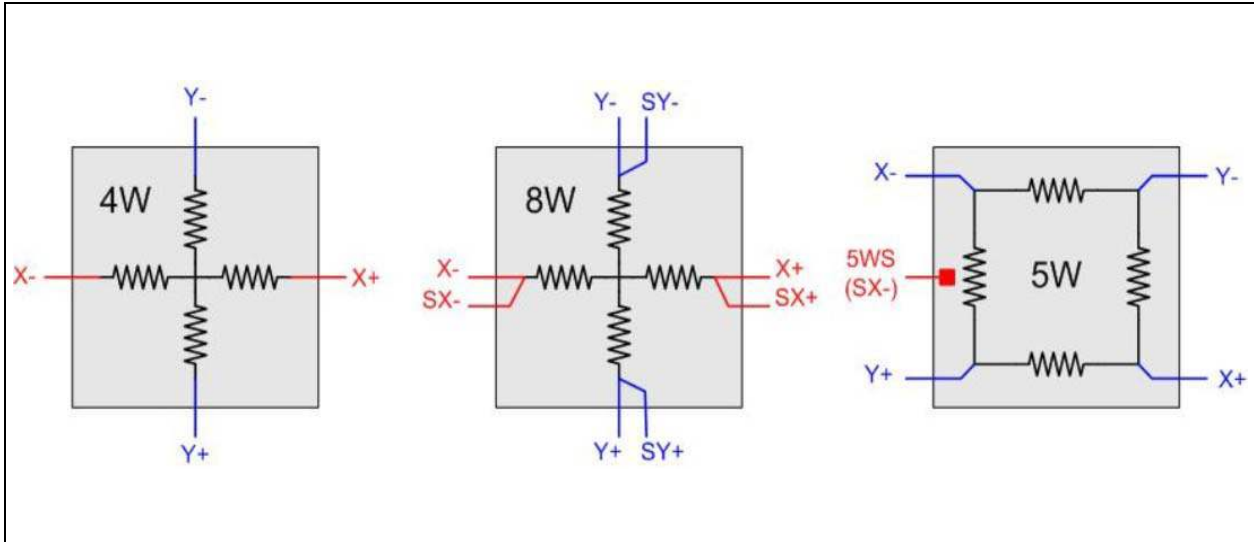

### 2.4.1 Connector: “4WZIF” – 4-Conductor FFC (flat flex)

JST part number: JST-04FM-1.st (LF)(SN) (4-position low insertion force flat flex connector)

**TABLE 2-1: 4WZIF PIN ASSIGNMENTS**

PIN#	FUNCTION
1	Y-
2	X-
3	Y+
4	X+



## 2.4.2 Connector: 'SENSOR' – 2x8 Header

Sullins part number: PTC08DBAN. 2 x 8, 0.100" spacing, .024" sq.post, .230" mating length.

**TABLE 2-2: SENSOR PIN ASSIGNMENTS**

Function	Pin#		Function
Y+	1	2	Y-
X+	3	4	SY-
5WSX-	5	6	SY+
X-	7	8	Y+
Y-	9	10	X-
X-	11	12	5WSX-
Y+	13	14	SX+
X+	15	16	X+

**FIGURE 2-6: SENSOR CONNECTIONS**

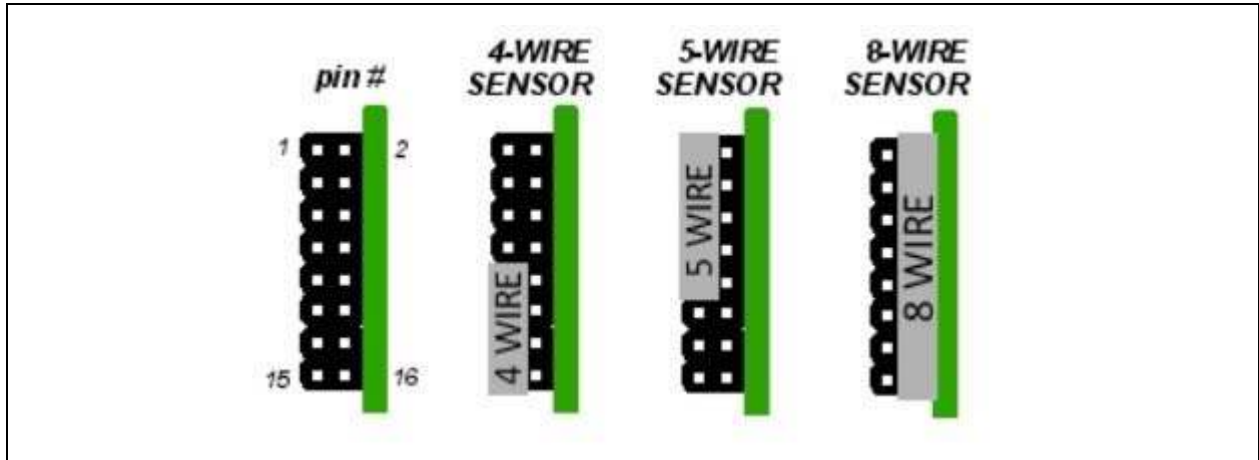

# mTouch™ AR1100 User's Guide

---

NOTES:

## Chapter 3. Operation

### 3.1 CONFIGURATION

The AR1100 Touch Screen Controller Board is operational out of the box. Communication protocol is detected automatically (as described below) and the Mechanical mode jumper selects between 5-wire (jumper on) and 4/8-wire (jumper off). If a USB cable is connected, the AR1100 Touch Screen Controller Board will default to Mouse mode (HID-MOUSE). Additional configuration is possible (but generally, not necessary) using commands described in the AR1100 IC data sheet. The Microchip AR Configuration Utility Software can be used with the AR1100 Touch Screen Controller Board to modify (fine tune) operational parameters, change the 'default' USB device or actually update the control firmware. Any change made to the factory defaults is saved to internal, nonvolatile memory.

### 3.2 COMMUNICATION

The AR1100 Touch Screen Controller Board supports both RS-232 and USB. The controller will automatically detect and select between the two at power-up. The USB support is further defined to be one of three devices – HID-GENERIC, HID-MOUSE or HID-DIGITIZER – the controller can be configured to power-up as any of the three devices but the factory default is HID-MOUSE.

### 3.3 DATA FORMAT

The touch report data format for each communication protocol is defined below. The HID-MOUSE and HID-DIGITIZER are compatible with intrinsic drivers of Windows® XP and Windows 7, respectively. The HID-GENERIC and RS-232 protocols require custom handling.

#### 3.3.1 Mode: HID-GENERIC, RS-232

**TABLE 3-1: TOUCH REPORT FORMAT – GENERIC**

BYTE	BIT							
	7	6	5	4	3	2	1	0
1	1	R	R	R	R	R	R	P
2	0	X6	X5	X4	X3	X2	X1	X0
3	0	0	X11	X10	X9	X8	X7	X6
4	0	Y6	Y5	Y4	Y3	Y2	Y1	Y0
5	0	0	Y11	Y10	Y9	Y8	Y7	Y6

**Note 1:** P Pen state 1: Pen down; 0: Pen up  
R (Reserved)  
X X ordinate of touch location (12 bits)  
Y Y ordinate of touch location (12 bits)

## 3.3.2 Mode: HID-MOUSE

The USB 'report' format is given below:

**TABLE 3-2: TOUCH REPORT FORMAT – MOUSE**

BYTE	BIT							
	7	6	5	4	3	2	1	0
1	0	0	0	0	0	B3	B2	B1
2	X7	X6	X5	X4	X3	X2	X1	X0
3	0	0	0	0	X11	X10	X9	X8
4	Y7	Y6	Y5	Y4	Y3	Y2	Y1	Y0
5	0	0	0	0	Y11	Y10	Y9	Y8
<b>Note 1:</b>	B1	Button 1 depressed (configurable, reacts to touch event/state (see the description below))						
	B2	Button 2 depressed ( <u>always 0</u> )						
	B3	Button 3 depressed ( <u>always 0</u> )						
	X	X ordinate of touch location (12 bits)						
	Y	Y ordinate of touch location (12 bits)						

As seen in Table 3-2 above, the AR1100 Touch Screen Controller Board provides flexibility to the 'Button 1' field in the HID-MOUSE touch report. The value of 'Button 1' and the touch reports issued in reaction to touch events is dictated by the operational parameter, TouchMode, (described in the AR1100 Resistive USB and RS-232 Touch Screen Controller data sheet, DS41606). In the summary below, touch report field "P" (pen) corresponds to 'Button 1'.

### 3.3.2.1 SUMMARY OF PARAMETER: *TouchMode*

In reaction to each touch state/event, the AR1100 issues 0,1,2 or 3 touch reports with pen state "P" (a 1-bit field) set as described below.

TouchMode[7:5] = PD[2:0] Response to event PD (PEN/TOUCH DOWN)

- b000 No touch report issued in response to the event
- b001 Touch report w/ P=0
- b010 Touch report w/ P=1
- b011 Touch report w/ P=1, then Touch report w/ P=0
- b100 Touch report w/ P=0, then Touch report w/ P=1, then Touch report w/ P=0
- b101 Touch report w/ P=0, then Touch report w/ P=1

TouchMode[4:3] = PM[1:0] Response to event PM (PEN/TOUCH MOVEMENT)

- b000 No touch report issued in response to the event
- b001 Touch report w/ P=0
- b010 Touch report w/ P=1

TouchMode[2:0] = PU[2:0] Response to event PU (PEN/TOUCH UP)

- b000 No touch report issued in response to the event
- b001 Touch report w/ P=0
- b010 Touch report w/ P=1
- b011 Touch report w/ P=1, then Touch report w/ P=0
- b100 Touch report w/ P=0, then Touch report w/ P=1, then Touch report w/ P=0
- b101 Touch report w/ P=0, then Touch report w/ P=1

### 3.3.3 Mode: HID-DIGITIZER

The USB 'report' format is given below:

**TABLE 3-3: TOUCH REPORT FORMAT – DIGITIZER**

BYTE	BIT							
	7	6	5	4	3	2	1	0
1	0	0	0	0	0	0	P	T
2	0	0	0	0	0	0	0	0
3	X7	X6	X5	X4	X3	X2	X1	X0
4	0	0	0	0	X11	X10	X9	X8
5	Y7	Y6	Y5	Y4	Y3	Y2	Y1	Y0
6	0	0	0	0	Y11	Y10	Y9	Y8

**Note 1:** T1 Tip switch  
P Proximity (in range) – always 1  
X X ordinate of touch location (12 bits)  
Y Y ordinate of touch location (12 bits)

For flexibility, the value and behavior of the 'tip switch' data entity ("T") reflects the pen up/down state (similar to the 'Button 1' description in HID-MOUSE mode).

## 3.4 LED INDICATOR

The Microchip AR1100 Touch Screen Controller Board is equipped with a LED indicator to display controller status as follows:

**TABLE 3-4: LED INDICATOR**

Behavior	Status
LED blinks slowly (once per second)	Controller is powered, awake and no touch is detected.
LED blinks rapidly (5 times per second)	Controller detects a touch.
LED is off	Controller has no power or is asleep (suspended).

# mTouch™ AR1100 User's Guide

---

NOTES:

**Chapter 4. Software Device Drivers**

---

---

Microchip Technology has device driver software available for all AR1100 touch screen controller chip and board solutions.

The software drivers may be downloaded at no additional charge at: [www.microchip.com/mtouch](http://www.microchip.com/mtouch)

The Microchip device driver software enables you to configure the touch screen operation to meet your needs. The following is a list of features available with Microchip's software:

1. Touch screen calibration/linearization/alignment (4, 9, 25-point)
2. Adjustable calibration inset
3. Touch modes:
  - Normal mouse emulation
  - Touch-Up mode
  - Touch-Down mode
4. Other special features are also included. Please see the complete driver manuals available at the [www.microchip.com](http://www.microchip.com) web site for further details.

**Note:** Microchip device drivers vary between operating systems and operating system varieties and versions.

# mTouch™ AR1100 User's Guide

---

NOTES:



**Chapter 5. Accessories**

**5.1 COMMUNICATION CABLES**

**TABLE 5-1: COMMUNICATION CABLES**

Part Number	Description
C72-080S1F-09XDXF	6' RS-232 cable. Female DB9 to 8-position SIP socket Direct connect to <b>H1</b> header
C72-080S1F-04XAXM-D	6' USB cable. Male type A USB to 8-position SIP socket Direct connect to <b>H1</b> header

**5.2 TOUCH SCREEN CABLES**

**TABLE 5-2: TOUCH SCREEN CABLES**

Part Number	Description
C18-040S1F-040G1M	4-Wire – 18", 4-position, 0.100" SIP header to SIP socket. Direct connect to SENSOR header
C18-050S1F-050G1M	5-Wire – 18", 5-position, 0.100" SIP header to SIP socket Direct connect to SENSOR header
C18-080S1F-080G1M	8-Wire – 18", 8-position, 0.100" SIP header to SIP socket Direct connect to SENSOR header
C12-040S1F-041Z1F	4-Wire – 12", 4-position, 0.100" socket to 1 mm flat flex conector. Direct connect to flat flex connector
10022-100	6" 4-wire touch screen 'crossover' cable, 4-position SIP socket to SIP header Direct connect to SENSOR header
10023-100	6" 5-wire touch screen 'crossover' cable, 5-position SIP socket to SIP header Direct connect to SENSOR header
10024-100	6" 8-wire touch screen 'crossover' cable, 8-position SIP socket to SIP header Direct connect to SENSOR header

# mTouch™ AR1100 User's Guide

---

NOTES:

## **Chapter 6. Support**

---

---

Webticket Support System: <http://support.microchip.com>

In the event that you need to contact Microchip via telephone or via our support e-mail, please take a minute to identify these items prior to contacting Microchip technical support staff.

- Information about Microchip reseller, if not purchased directly from Microchip
- Touch Screen type and Manufacturer
- Communication type
- Microchip driver and revision
- Operating system and service pack releases
- A brief summary of the problem that you are having

# mTouch™ AR1100 User's Guide

---

NOTES:

---

---

## Chapter 7. Touch Screen Selection

---

---

The 4 and 8-wire touch screens are typically produced with higher resistance transparent conductive film (ITO Indium Tin Oxide) than 5-wire touch screens. Most often, touch screen resistance falls within 100-400 Ohm per square. Because 4 and 8-wire touch screens typically have a higher resistance than 5-wire sensors, you will find most battery-powered applications using this technology. You will also find that 4 and 8-wire touch screens are more linear than 5-wire ones.

The 5-wire touch screens are typically more mechanically durable (top sheet does not need to be linear) and are less affected by environmental variation. 5-wire touch screens come in a wide variety of sheet resistance. In some cases, because of the 5-wire construction, the resistance may be lower than the 50 Ohm specification. While these touch screens require more power to drive them, this does not imply poor quality.

Once resistance drops below an optimum level, so does the resolution. In contrast, as resistance increases, depending upon the construction, contact resistance begins to negatively affect the touch screen's performance. The negative effect of a high or low resistance touch screen can be managed by properly implementing the correct circuit. It should be understood that extremes in either direction will negatively influence the performance of any efficient circuit design. In order to maximize efficiency and performance, a higher resistance, linear, environmentally stable touch screen is recommended.

Your product design requirements will help you identify the touch screen technology and construction that will best suit your application. Please contact Microchip Technology Inc. for more unbiased touch screen material science information and a list of recommended Microchip controller designs to fit your application.

# mTouch™ AR1100 User's Guide

---

NOTES:

**Index**

<b>A</b>		<b>T</b>	
Accessories.....	25	The Microchip Web Site.....	6
AR1100 Core Features.....	9	Touch Screen Cables.....	25
AR1100BRD.....	9	Touch Screen Selection.....	29
<b>C</b>		<b>W</b>	
Communication.....	14, 19	WWW Address.....	6
Communication Cables.....	25		
Configuration.....	19		
Connections.....	13		
Customer Support.....	6, 7		
<b>D</b>			
Data Format.....	19		
Document Layout.....	6		
Documentation Layout.....	6		
Documentation Revision History.....	6		
<b>E</b>			
Electrical.....	12		
<b>I</b>			
Internet Address.....	6		
Introduction.....	5, 9		
<b>L</b>			
LED Indicator.....	19		
<b>M</b>			
Mechanical.....	10		
Microchip Internet Web Site.....	6		
Mode			
HID-DIGITIZER.....	21		
HID-GENERIC, RS-232.....	19		
HID-MOUSE.....	20		
Mounting.....	13		
<b>O</b>			
Operation.....	19		
<b>P</b>			
Power.....	13		
Preface.....	5		
Product Description.....	9		
Product Overview.....	9		
<b>R</b>			
Reading, Recommended.....	6		
Recommended Reading.....	6		
<b>S</b>			
Sensor.....	16		
Software Device Drivers.....	23		
Support.....	27		



# MICROCHIP

## Worldwide Sales and Service

### AMERICAS

**Corporate Office**  
2355 West Chandler Blvd.  
Chandler, AZ 85224-6199  
Tel: 480-792-7200  
Fax: 480-792-7277  
Technical Support:  
<http://www.microchip.com/support>  
Web Address:  
[www.microchip.com](http://www.microchip.com)

**Atlanta**  
Duluth, GA  
Tel: 678-957-9614  
Fax: 678-957-1455

**Boston**  
Westborough, MA  
Tel: 774-760-0087  
Fax: 774-760-0088

**Chicago**  
Itasca, IL  
Tel: 630-285-0071  
Fax: 630-285-0075

**Cleveland**  
Independence, OH  
Tel: 216-447-0464  
Fax: 216-447-0643

**Dallas**  
Addison, TX  
Tel: 972-818-7423  
Fax: 972-818-2924

**Detroit**  
Farmington Hills, MI  
Tel: 248-538-2250  
Fax: 248-538-2260

**Indianapolis**  
Noblesville, IN  
Tel: 317-773-8323  
Fax: 317-773-5453

**Los Angeles**  
Mission Viejo, CA  
Tel: 949-462-9523  
Fax: 949-462-9608

**Santa Clara**  
Santa Clara, CA  
Tel: 408-961-6444  
Fax: 408-961-6445

**Toronto**  
Mississauga, Ontario,  
Canada  
Tel: 905-673-0699  
Fax: 905-673-6509

### ASIA/PACIFIC

**Asia Pacific Office**  
Suites 3707-14, 37th Floor  
Tower 6, The Gateway  
Harbour City, Kowloon  
Hong Kong  
Tel: 852-2401-1200  
Fax: 852-2401-3431

**Australia - Sydney**  
Tel: 61-2-9868-6733  
Fax: 61-2-9868-6755

**China - Beijing**  
Tel: 86-10-8569-7000  
Fax: 86-10-8528-2104

**China - Chengdu**  
Tel: 86-28-8665-5511  
Fax: 86-28-8665-7889

**China - Chongqing**  
Tel: 86-23-8980-9588  
Fax: 86-23-8980-9500

**China - Hangzhou**  
Tel: 86-571-2819-3187  
Fax: 86-571-2819-3189

**China - Hong Kong SAR**  
Tel: 852-2401-1200  
Fax: 852-2401-3431

**China - Nanjing**  
Tel: 86-25-8473-2460  
Fax: 86-25-8473-2470

**China - Qingdao**  
Tel: 86-532-8502-7355  
Fax: 86-532-8502-7205

**China - Shanghai**  
Tel: 86-21-5407-5533  
Fax: 86-21-5407-5066

**China - Shenyang**  
Tel: 86-24-2334-2829  
Fax: 86-24-2334-2393

**China - Shenzhen**  
Tel: 86-755-8203-2660  
Fax: 86-755-8203-1760

**China - Wuhan**  
Tel: 86-27-5980-5300  
Fax: 86-27-5980-5118

**China - Xian**  
Tel: 86-29-8833-7252  
Fax: 86-29-8833-7256

**China - Xiamen**  
Tel: 86-592-2388138  
Fax: 86-592-2388130

**China - Zhuhai**  
Tel: 86-756-3210040  
Fax: 86-756-3210049

### ASIA/PACIFIC

**India - Bangalore**  
Tel: 91-80-3090-4444  
Fax: 91-80-3090-4123

**India - New Delhi**  
Tel: 91-11-4160-8631  
Fax: 91-11-4160-8632

**India - Pune**  
Tel: 91-20-2566-1512  
Fax: 91-20-2566-1513

**Japan - Yokohama**  
Tel: 81-45-471- 6166  
Fax: 81-45-471-6122

**Korea - Daegu**  
Tel: 82-53-744-4301  
Fax: 82-53-744-4302

**Korea - Seoul**  
Tel: 82-2-554-7200  
Fax: 82-2-558-5932 or  
82-2-558-5934

**Malaysia - Kuala Lumpur**  
Tel: 60-3-6201-9857  
Fax: 60-3-6201-9859

**Malaysia - Penang**  
Tel: 60-4-227-8870  
Fax: 60-4-227-4068

**Philippines - Manila**  
Tel: 63-2-634-9065  
Fax: 63-2-634-9069

**Singapore**  
Tel: 65-6334-8870  
Fax: 65-6334-8850

**Taiwan - Hsin Chu**  
Tel: 886-3-5778-366  
Fax: 886-3-5770-955

**Taiwan - Kaohsiung**  
Tel: 886-7-536-4818  
Fax: 886-7-330-9305

**Taiwan - Taipei**  
Tel: 886-2-2500-6610  
Fax: 886-2-2508-0102

**Thailand - Bangkok**  
Tel: 66-2-694-1351  
Fax: 66-2-694-1350

### EUROPE

**Austria - Wels**  
Tel: 43-7242-2244-39  
Fax: 43-7242-2244-393

**Denmark - Copenhagen**  
Tel: 45-4450-2828  
Fax: 45-4485-2829

**France - Paris**  
Tel: 33-1-69-53-63-20  
Fax: 33-1-69-30-90-79

**Germany - Munich**  
Tel: 49-89-627-144-0  
Fax: 49-89-627-144-44

**Italy - Milan**  
Tel: 39-0331-742611  
Fax: 39-0331-466781

**Netherlands - Drunen**  
Tel: 31-416-690399  
Fax: 31-416-690340

**Spain - Madrid**  
Tel: 34-91-708-08-90  
Fax: 34-91-708-08-91

**UK - Wokingham**  
Tel: 44-118-921-5869  
Fax: 44-118-921-5820

08/02/11