

REVISIONS			
LTR	DESCRIPTION	DATE	APPROVED
F	REVISED PER OG1Z-0020-99	05-SEPT-00	
G	REVISED PER DCR R030112 - COLOR STRIPE CHANGE	30-APR-03	JKUSTER

**If this document is printed it becomes uncontrolled.
Check for the latest revision.**

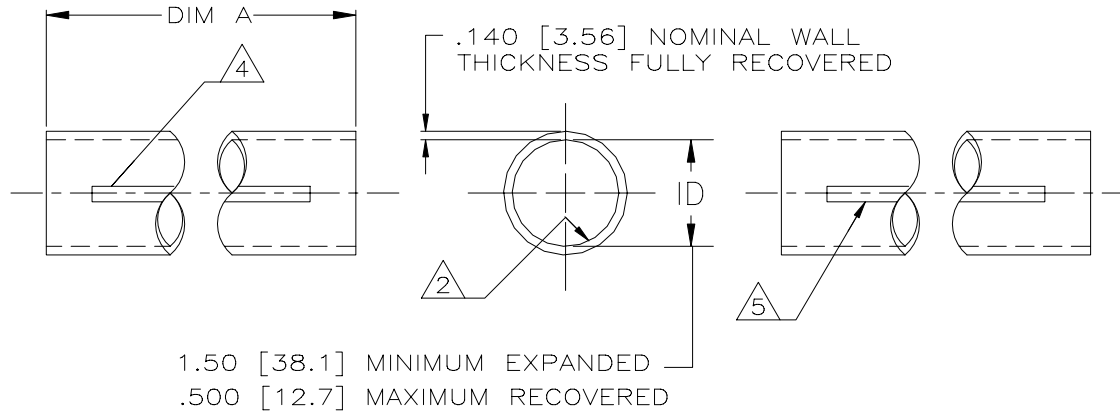

NOTES:

- MATERIAL: BLACK POLYOLEFIN, COMPLIES WITH MIL-23053/15-103-0.
- SEALANT THROUGHOUT TOTAL LENGTH OF INSIDE DIAMETER.
- DIMENSIONS APPLY WITHOUT SEALANT.
- PRODUCT IS MARKED "AMP MIL-23053/15-103-0 90°C 600V MAXIMUM" IN WHITE CHARACTERS ON SURFACE INDICATED.
- PRODUCT IS MARKED "AMP 608507 1.50-.50"/38.1-12.7mm 1/0-3/0 AWG", WITH DATE CODE, IN WHITE CHARACTERS ON SURFACE INDICATED.

11.81-12.19 [300-309.6]	608507-5
48.00-49.00 [1219.2-1244.6]	608507-4
DIMENSION A (LENGTH)	PART NO

SPECIFICATION CONTROL DRAWING

UNLESS OTHERWISE SPECIFIED DIMENSIONS ARE IN INCHES. METRIC DIMENSIONS ARE IN BRACKETS. DECIMALS .XXX ± [mm] .XX ± [mm] ANGLES .X ± WEIGHT lbs [g]	DRAWN	MFORONDA	03/04/03	 RAYCHEM PRODUCTS 305 CONSTITUTION DRIVE MENLO PARK, CALIFORNIA 94025		
	CHECKED					
	APPROVED	JKUSTER	03/04/03			
	APPROVED					
CAD NAME R0300112				TITLE TUBING, HEAT SHRINK AMPSULATION, MHWP31, 1.50 DIA.		
THIRD ANGLE PROJECTION			SIZE B	CODE IDENT. NO. 06090	DWG. NO. C-608507	REV G
DO NOT SCALE THIS DRAWING					SHEET 1 OF 1	