

PRODUCT NUMBER	PLATING OPT.	HSG&FRAME COLOR
10112634-101	OPTION 1	BLACK
10112634-101LF	OPTION 2	BLACK
10112634-121	OPTION 1	NATURAL
10112634-121LF	OPTION 2	NATURAL

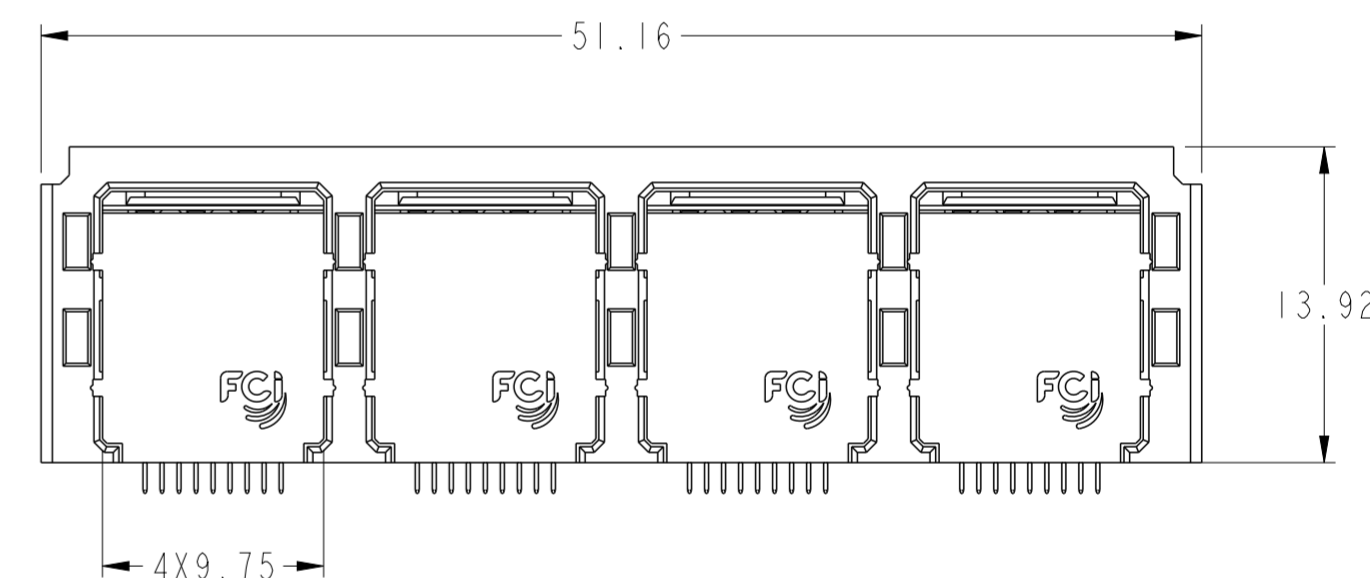
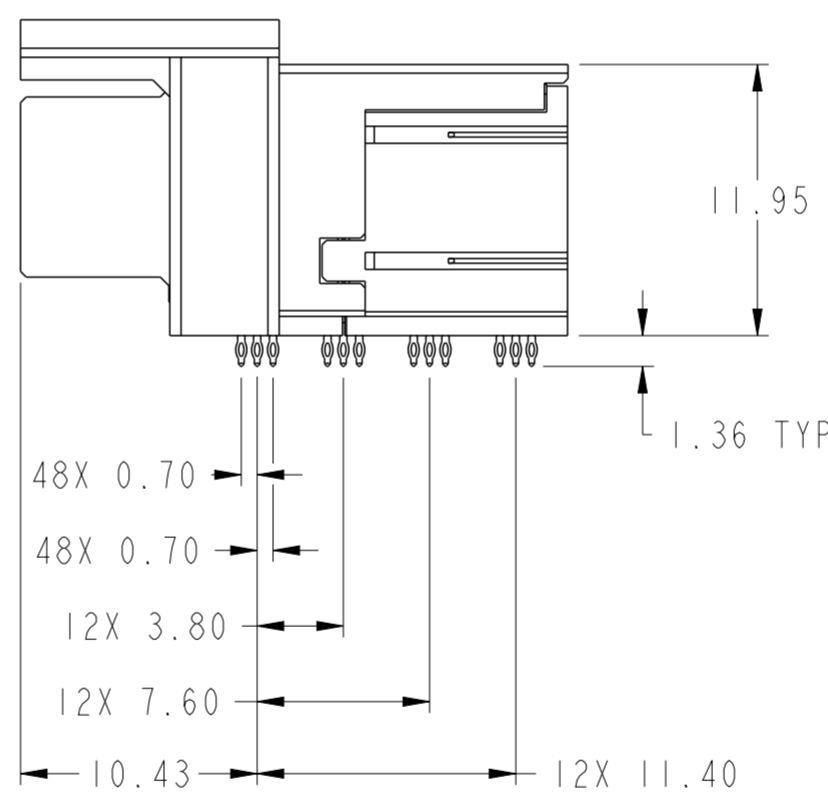
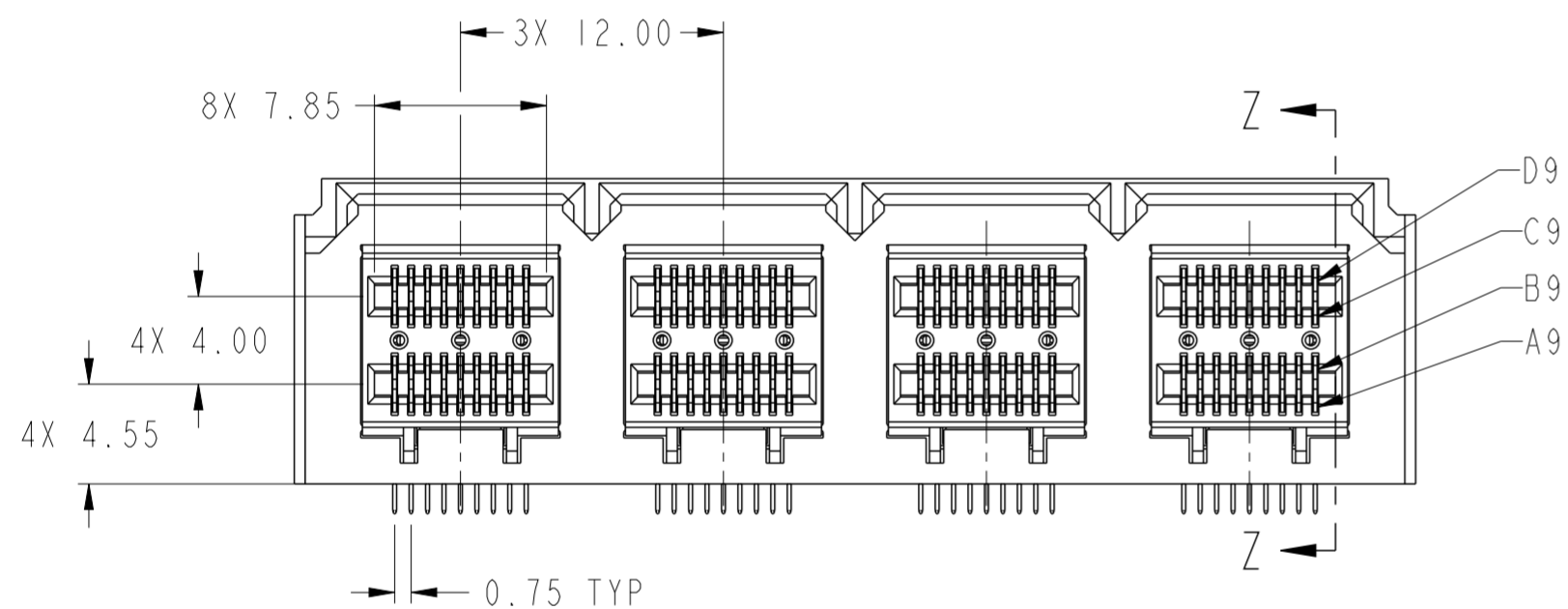
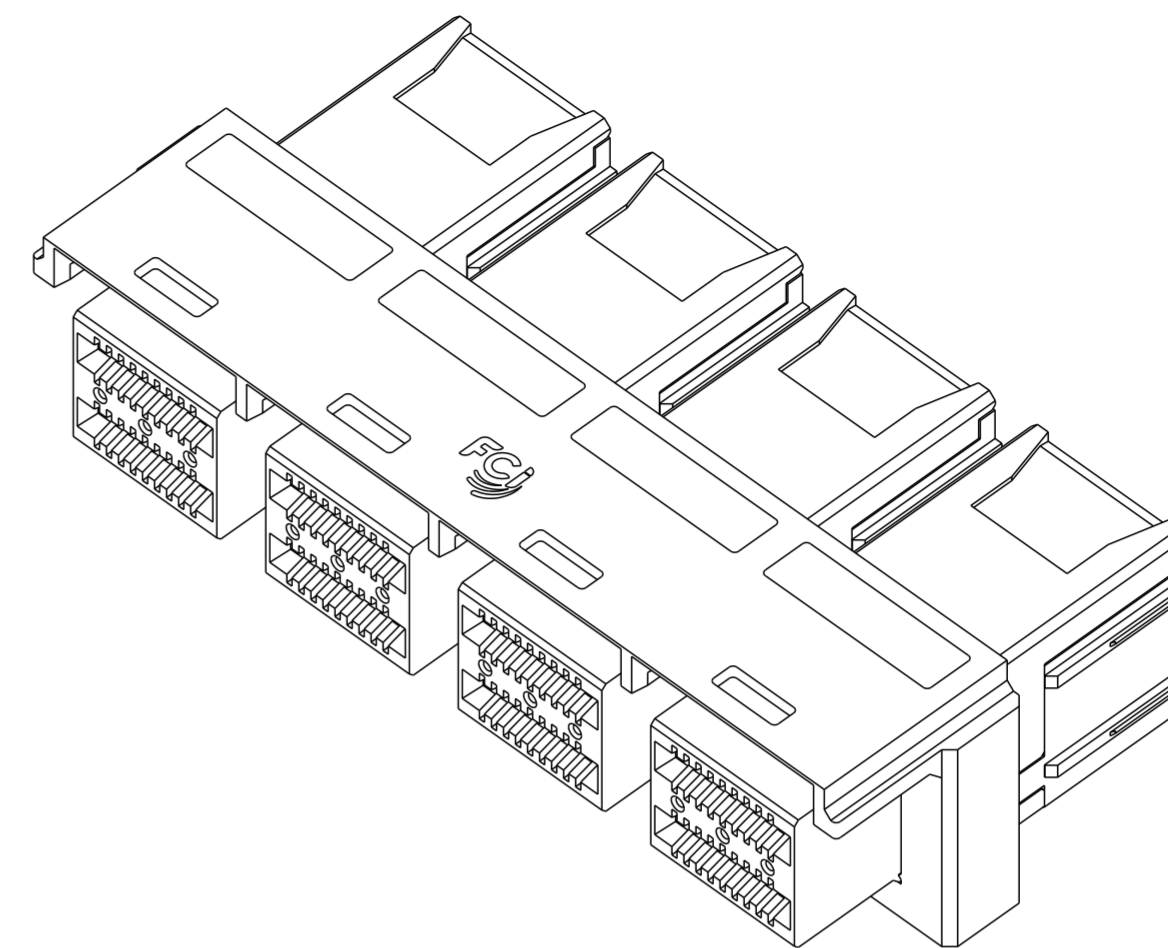
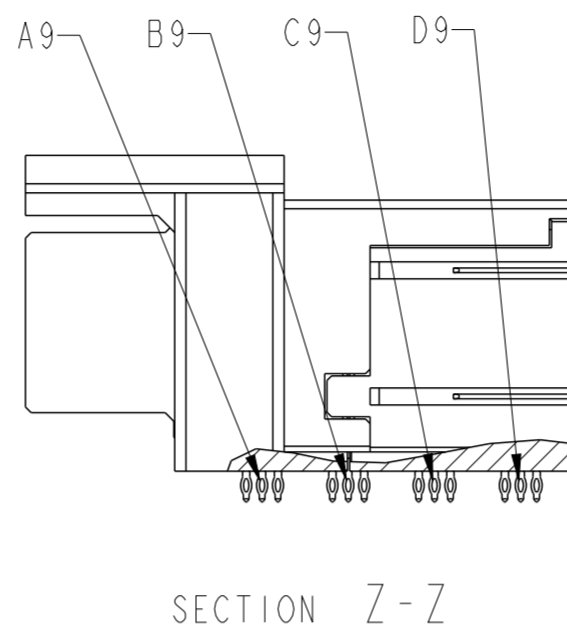
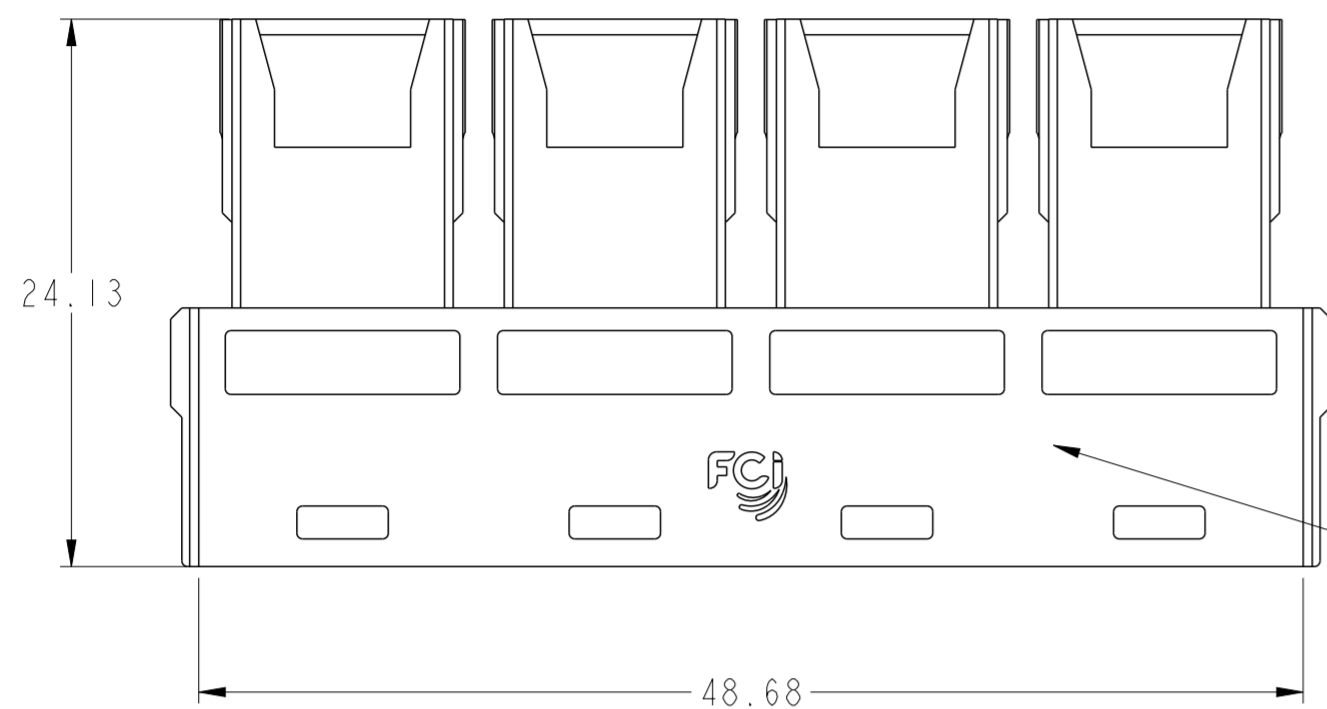

- NOTES:
- MATERIALS:
CONNECTOR HOUSING: HIGH TEMPERATURE THERMOPLASTIC, GLASS FILLED, UL 94V-0
TERMINALS: COPPER ALLOY
 - FINISHES:
CONTACT AREA: 0.76µm GOLD OVER 2.54µm MIN NICKEL
TAIL AREA:
OPTION 1: 0.76µm - 1.52µm TIN/LEAD (90/10) OVER 2.54µm MIN NICKEL.
OPTION 2: 0.76µm - 1.52µm TIN (LEAD FREE) OVER 2.54µm MIN NICKEL.
 - PRODUCT SPECIFICATION: GS-12-650.
APPLICATION SPECIFICATION: GS-20-0356
PACKAGING SPECIFICATION: GS-14-1490
 - RECOMMENDED MOUNTING HARDWARE:
△ OPTION 1: M2 X 0.91mm SELF-THREADING SCREW
OPTION 2: M2 X 0.80mm SELF-THREADING SCREW
OPTION 3: M2 X 0.40mm SELF-THREADING SCREW
RECOMMENDED MOUNTING SCREW LENGTH: PCB THICKNESS + (2.5±0.35)mm △
 - THIS CONNECTOR IS DESIGNED TO MEET THE REQUIREMENTS OF INDUSTRY SPECIFICATION SFF-8643.
 - A △ SYMBOL WILL BE NEXT TO ANY DIMENSION, VIEW, OR NOTE THAT HAS BEEN MODIFIED WITH THE CURRENT DRAWING REVISION.

MATES WITH MINI-SAS HD ENDS IN:
10119217 SERIES (4i)
10119312 SERIES (4i)
10120086 SERIES (4i)
10120087 SERIES (4i)
10119576 SERIES (8i)
10119577 SERIES (8i)
10120088 SERIES (8i)
10120089 SERIES (8i)

spec ref	-	dr	Mark Gray	2010/08/04	projection	MM	size	A2	scale	3:1
tolerance std	ASME Y14.5	eng	Jackbin Zou	2015/12/09			ecn no	ELX-DG-17937-1		
TOLERANCES UNLESS OTHERWISE SPECIFIED		chr	Zhen Luo	2015/12/22				rel level	Released	
surface	✓	appr	Pei-Ming Zheng	2015/12/23	product family	MINI-SAS HD		rel level	Released	
ASME Y14.5	linear	0.X	±0.25		IX4 INTERNAL ASSEMBLY MINI-SAS HD	cat. no.	Product - Customer Drw	sheet 1 of 4	rev C	
		0.XX	±0.15							
	angular	0°	±1/2°							

RECOMMENDED PC BOARD LAYOUT

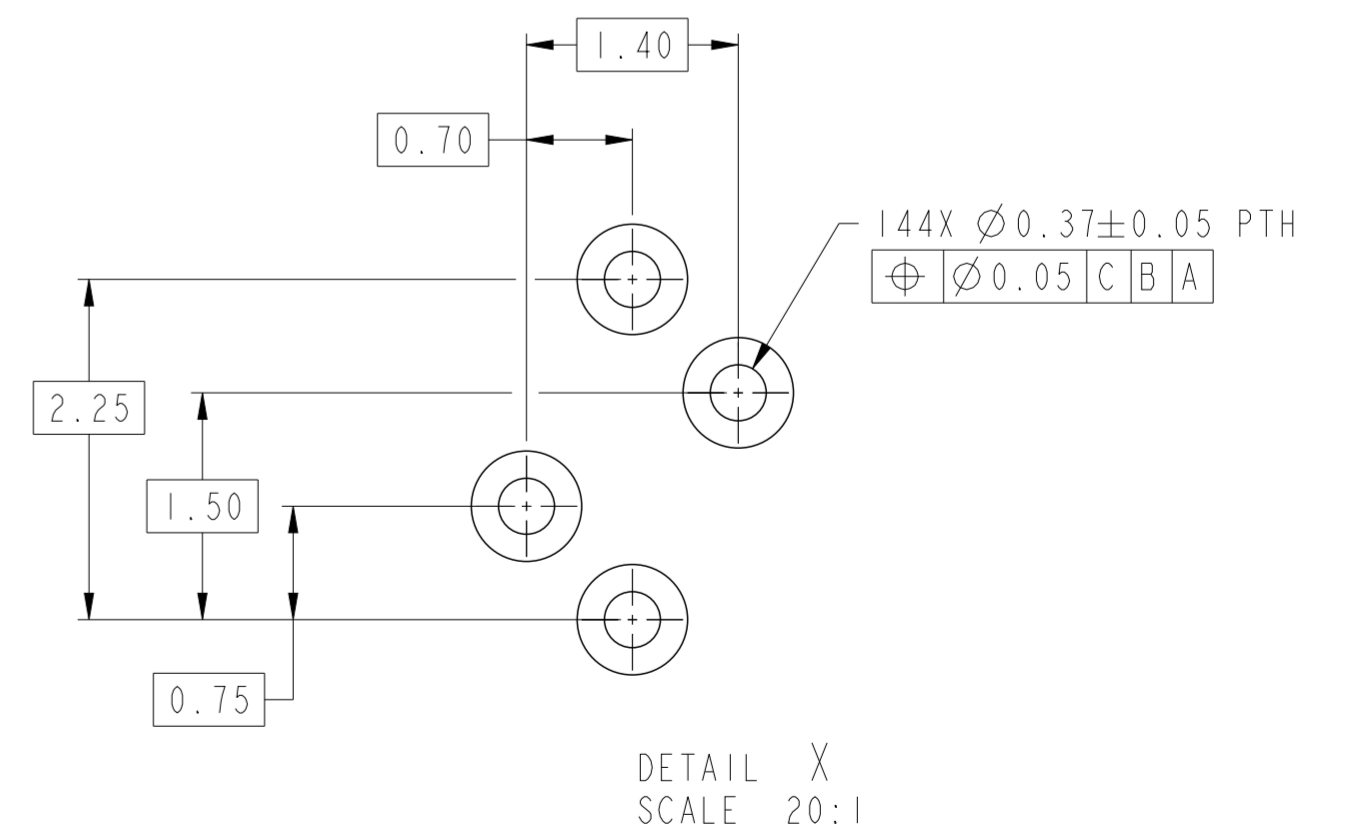
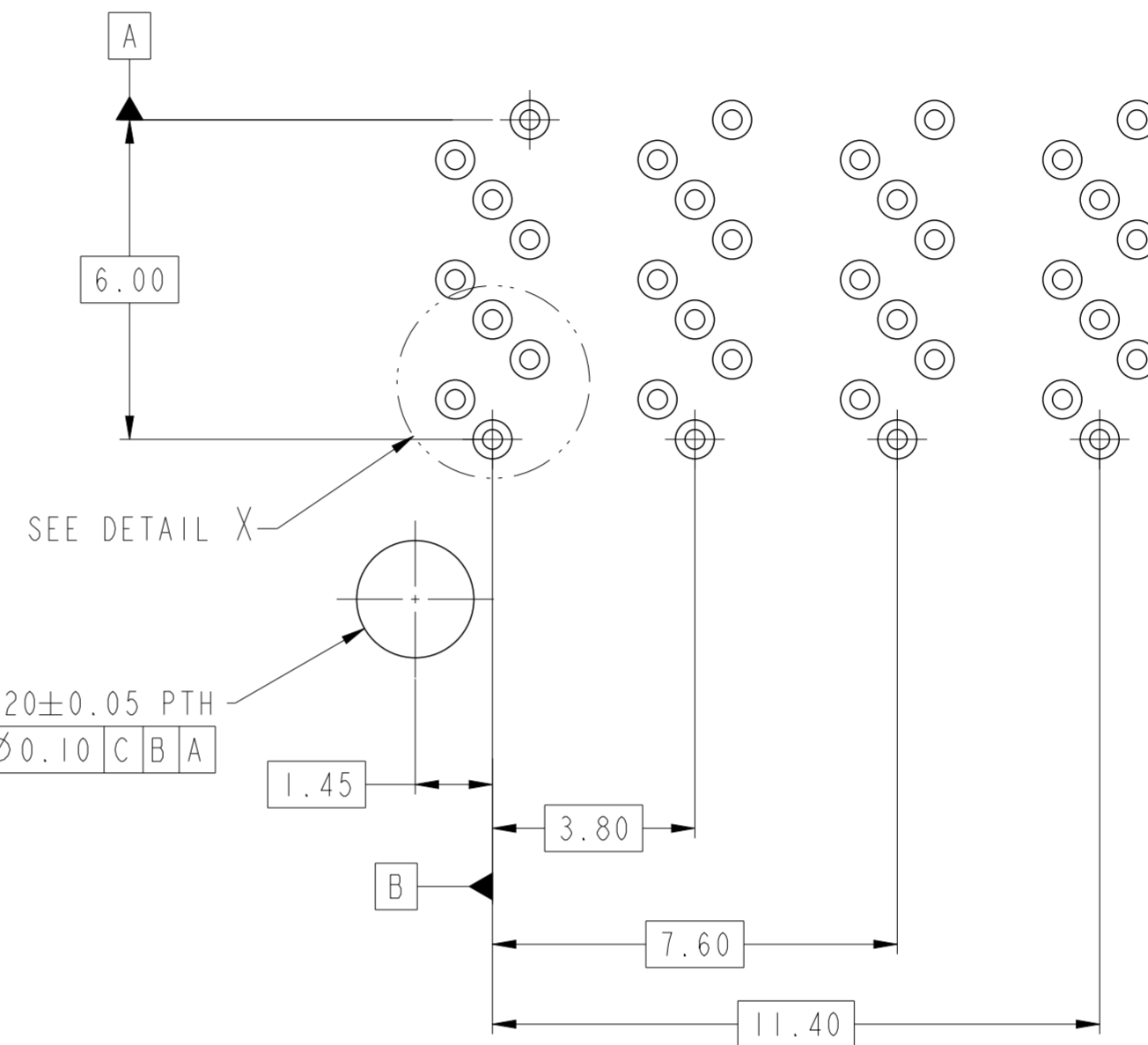
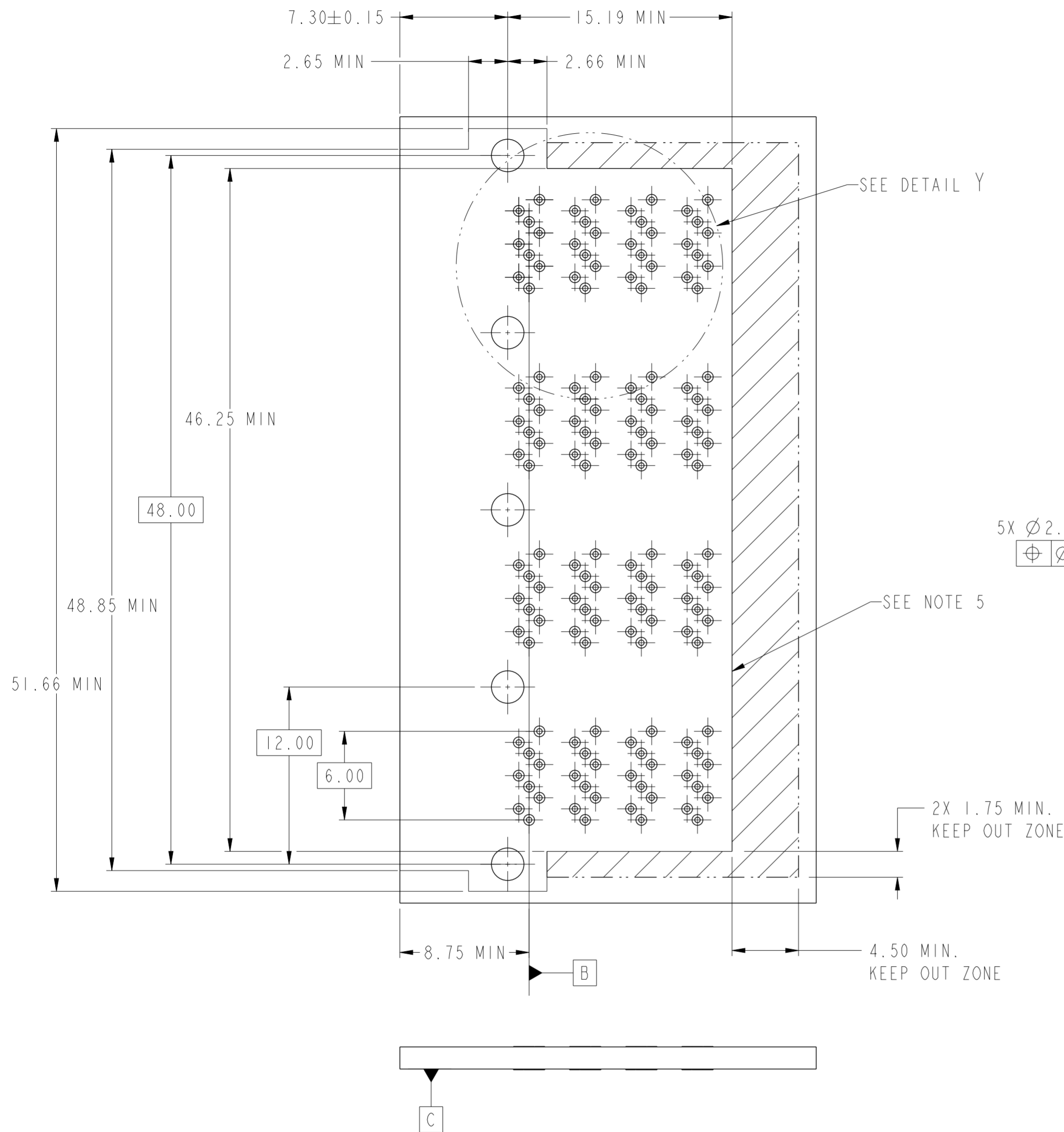

NOTES:

1. RECOMMENDED DRILL SIZE FOR A $\varnothing 0.37$ FINISHED PTH IS $\varnothing 0.457$ (#77 DRILL).
2. RECOMMENDED ANNULAR RING AROUND $\varnothing 0.37$ FINISHED PTH IS $\varnothing 0.73$.
3. MINIMUM RECOMMENDED SPACING : 14.00mm.
4. MINIMUM PCB THICKNESS : 1.57mm.
5. CONNECTOR KEEP OUT AREA.

spec ref	-	dr	Mark Gray	2010/08/04	projection	MM	size	A2	scale	2:1
tolerance std	ASME Y14.5	eng	Jacklin Zou	2015/12/09			ecn no	ELX-DG-17937-1	rel level	Released
TOLERANCES UNLESS OTHERWISE SPECIFIED		chr	Zhen Luo	2015/12/22						
		appr	Pei-Ming Zheng	2015/12/23						
surface	✓	product family	MINI-SAS HD			product family	MINI-SAS HD	rel level	Released	
linear	0.X ±0.25	0.XX ±0.15	0.XXX ±	0° ±1/2°	www.fci.com	cat. no.	-	Product - Customer Drw	sheet 2 of 4	
angular	0°	±1/2°								
TITLE		IX4 INTERNAL ASSEMBLY			MINI-SAS HD		dwg no	10112634	rev	C

PIN OUT DESIGNATIONS

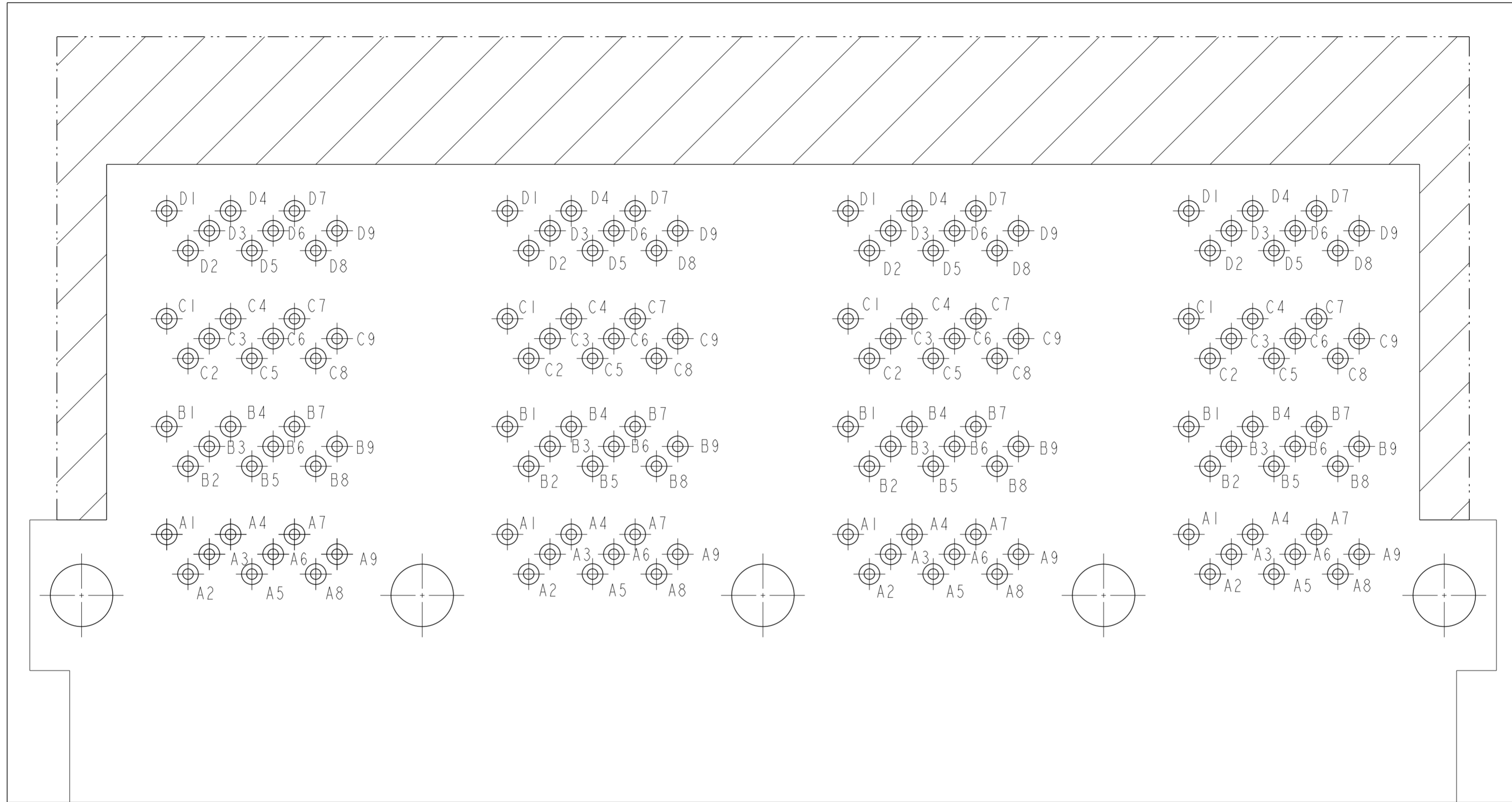

spec ref	-	dr	Mark Gray	2010/08/04	projection	MM	size	A2	scale	2:1												
tolerance std	ASME Y14.5	eng	Jacklin Zou	2015/12/09			ecn no	ELX-DG-17937-1	rel level	Released												
TOLERANCES UNLESS OTHERWISE SPECIFIED		chr	Zhen Luo	2015/12/22							product family	MINI-SAS HD										
surface	<table border="1"> <tr> <td>linear</td> <td>0.X</td> <td>±0.25</td> </tr> <tr> <td></td> <td>0.XX</td> <td>±0.15</td> </tr> <tr> <td></td> <td>0.XXX</td> <td>±</td> </tr> <tr> <td>angular</td> <td>0°</td> <td>±1/2°</td> </tr> </table>	linear	0.X	±0.25		0.XX	±0.15		0.XXX	±	angular	0°	±1/2°	appr	Pei-Ming Zheng	2015/12/23	title	IX4 INTERNAL ASSEMBLY	dwg no	10112634	rev	C
linear	0.X	±0.25																				
	0.XX	±0.15																				
	0.XXX	±																				
angular	0°	±1/2°																				
ASME Y14.5		www.fci.com	cat. no.	-	Product - Customer Drw	sheet 3 of 4																



Copyright FCI.

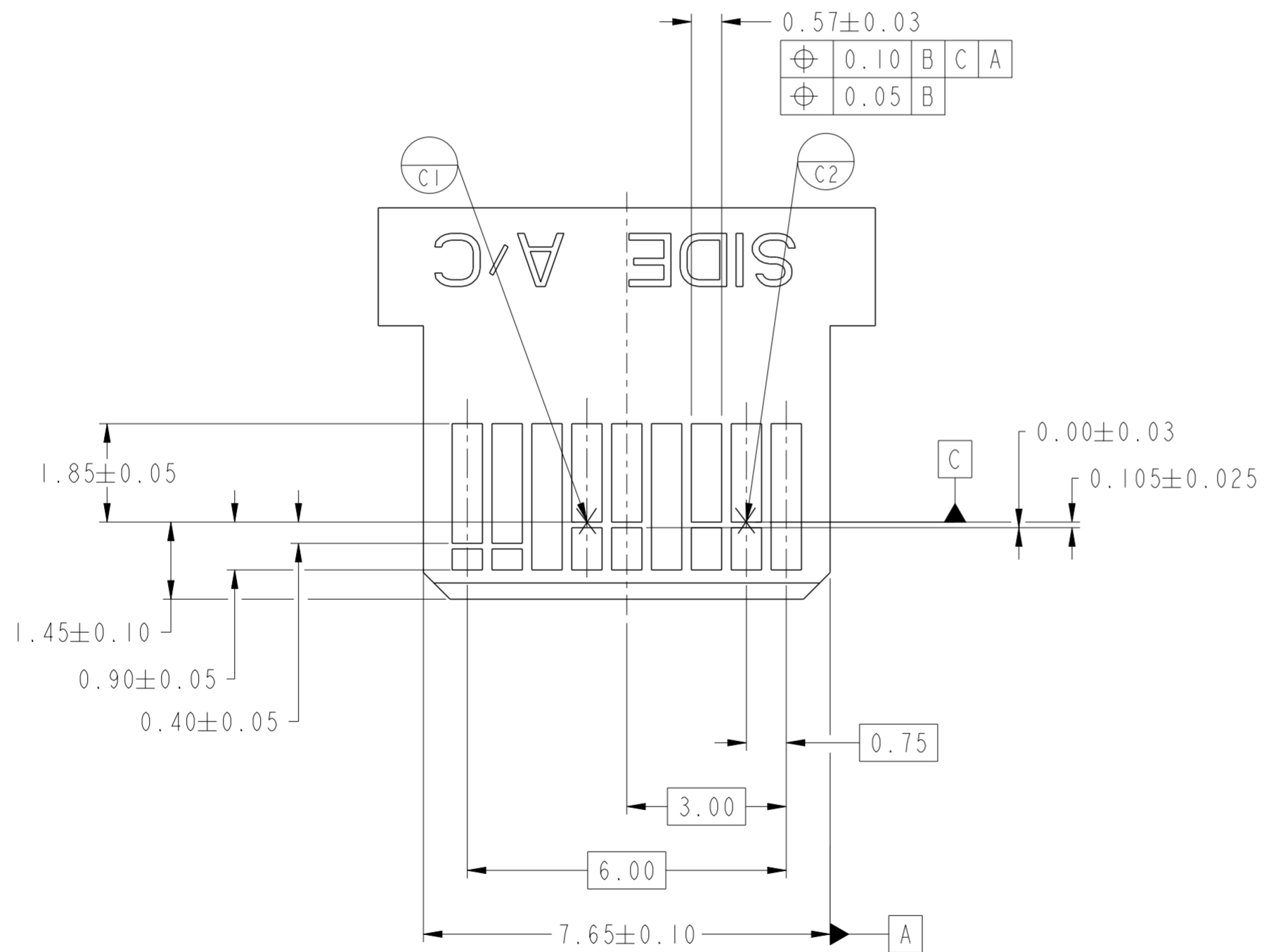
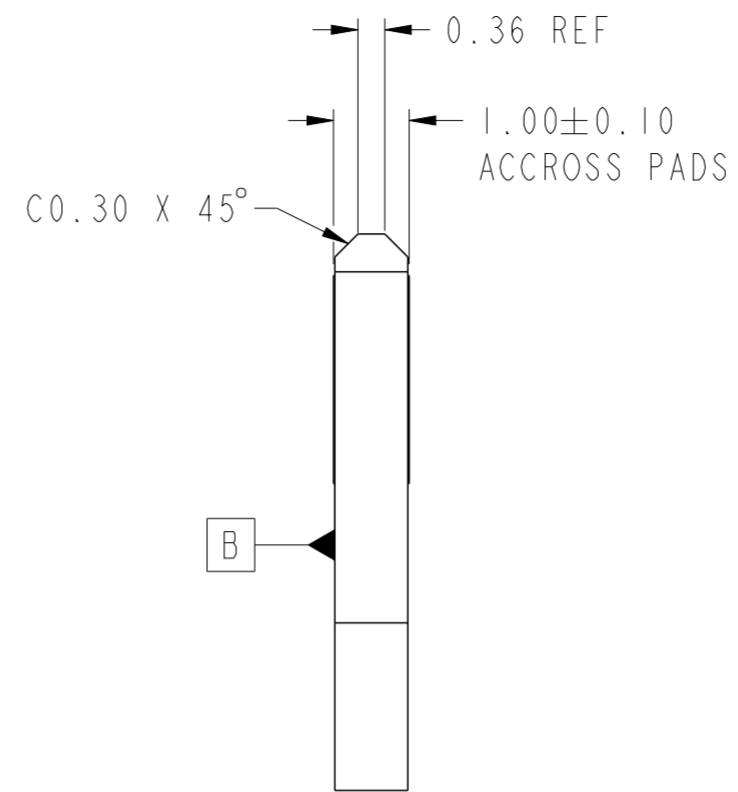
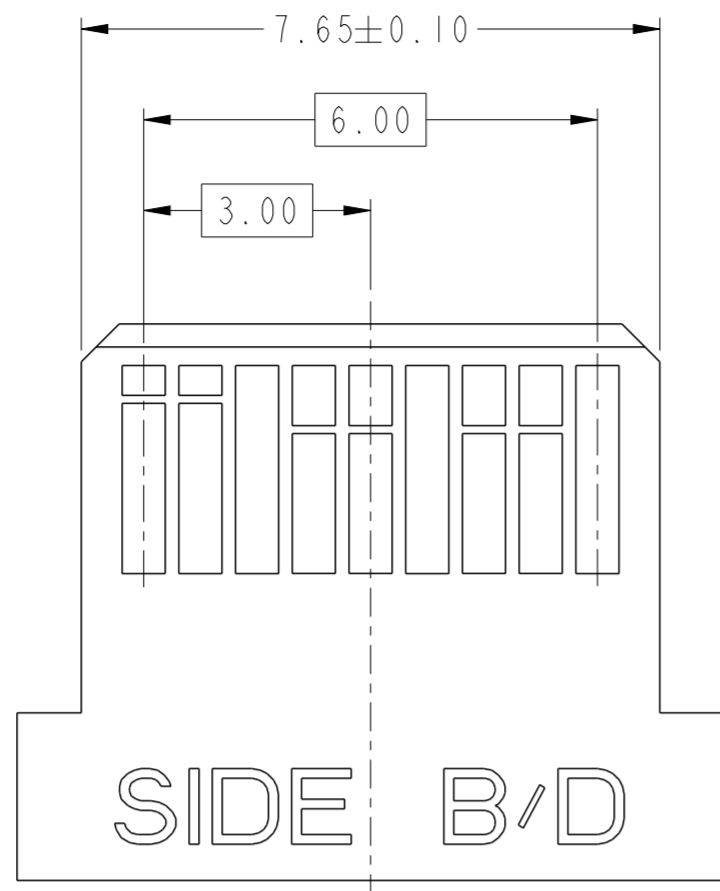

NOTES:

- 0.05 MINIMUM KEEP OUT SOLDER MASK AROUND ALL PADS.
- DATUM C TARGETS ARE DEFINED BY THE RESPECTIVE PAD CENTER LINES AND THE LEADING EDGE OF THE TARGET PADS.

spec ref	-	dr	Mark Gray	2010/08/04	projection	MM	size	A2	scale	2:1				
tolerance std	ASME Y14.5	eng	Jacklin Zou	2015/12/09			ecn no	ELX-DG-17937-1						
TOLERANCES UNLESS OTHERWISE SPECIFIED		chr	Zhen Luo	2015/12/22			rel level	Released						
		appr	Pei-Ming Zheng	2015/12/23			product family	MINI-SAS HD						
surface	✓	linear	0.X	±0.25		title IX4 INTERNAL ASSEMBLY MINI-SAS HD	dwg no 10112634	rev C	ASME Y14.5		angular	0°	±1/2°	
		linear	0.XX	±0.15					www.fci.com	cat. no.	-		Product - Customer Drw	sheet 4 of 4
		linear	0.XXX	±										

