

THIS DRAWING AND THE SUBJECT MATTER SHOWN THEREON ARE CONFIDENTIAL AND THE PROPERTY OF BEL/STEWART/TRP CONNECTOR AND SHALL NOT BE REPRODUCED, COPIED, OR USED IN ANY MANNER WITHOUT THE WRITTEN CONSENT OF TRP CONNECTOR.

PRODUCT MAY BE PROTECTED BY ONE OR MORE OF THE FOLLOWING US PATENTS:  
 5736910 5939955 6425781 6428361 6554638 6840817 7123117  
 7429195 7717749 7808751 6217391 6149050 7924130

REVISIONS				
P	LTR	DESCRIPTION	DATE	APPD
C		EC-1411035 COMPANY LOGO CHANGE	18DEC2014	GZ TY

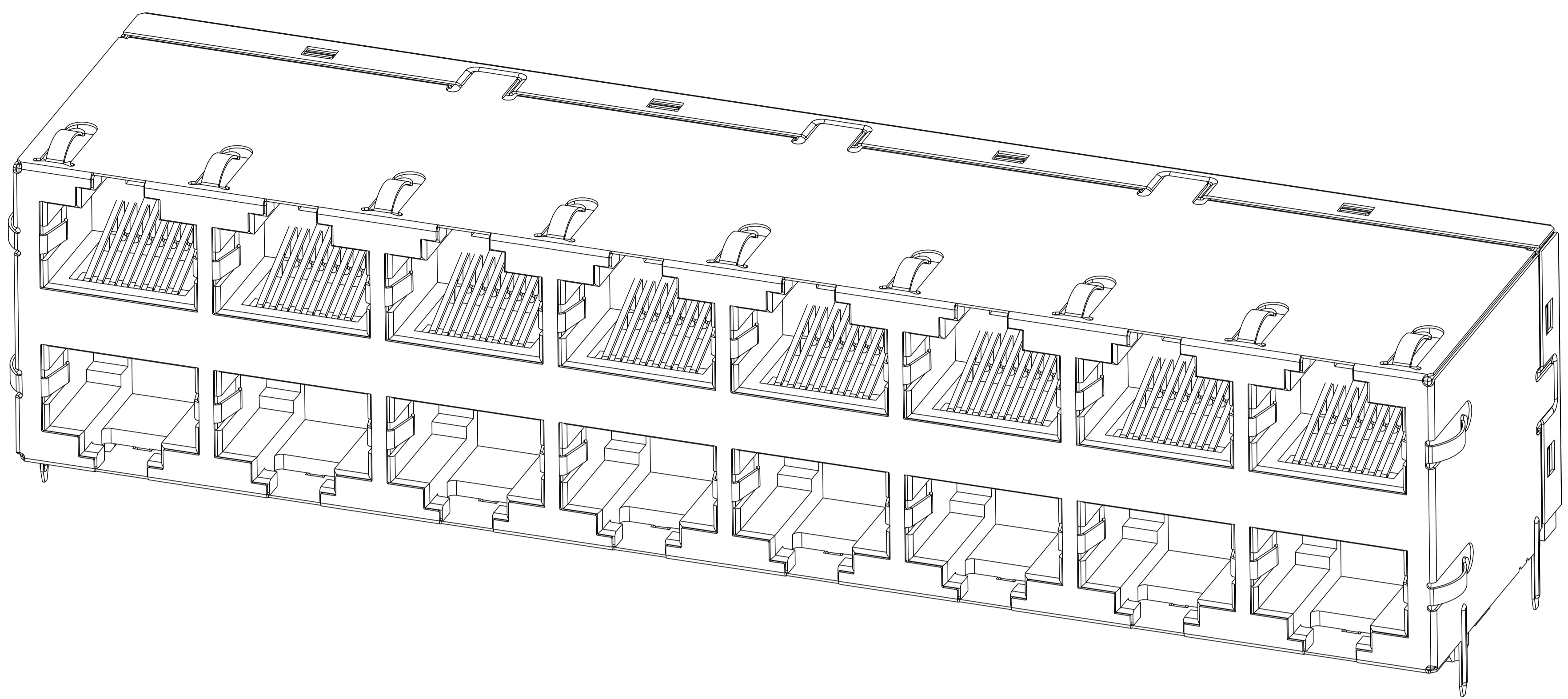

- MATERIALS:**  
 PLASTIC HOUSING: BLACK, THERMOPLASTIC FLAMMABILITY RATING UL 94V-0  
 SHIELD: BRASS, PREPLATED WITH 0.76um MIN SEMI-BRIGHT NICKEL,  
 POST DIPPED WITH 2.54um MIN SAC SOLDER ON SOLDER TAILS,  
 CONTACTS: PHOSPHOR BRONZE, 1.27um MIN OVERALL NICKEL  
 UNDERPLATE WITH SELECT 1.27um MIN GOLD AT MATING INTERFACE  
 AND 2.54um MIN MATTE TIN ON SOLDER TAILS.
- MAGNETICS**  
 APPLICATION: 10/100/1000 BASE-T  
 IMPEDANCE: 100 OHMS  
 TURNS RATIO (CHIP:CABLE): 1:1 ALL FOUR PAIRS  
 OPEN CIRCUIT INDUCTANCE (OCL): 350uH MIN @100kHz, 0.1VRMS,  
 8mADC BIAS FROM 0°C TO 70°C, ALL FOUR PAIRS  
 ALL FOUR PAIRS BI-DIRECTIONAL  
 PERFORMANCE @ 25°C:  
 INSERTION LOSS (IL): 1.1dB MAX FROM 0.5MHz TO 100MHz  
 RETURN LOSS (RL): 18dB MIN FROM 0.5MHz TO 40MHz  
 12-20LOG(f/80)dB MIN FROM 40.1MHz TO 100MHz  
 CROSSTALK ATTENUATION: 35dB MIN FROM 0.5MHz TO 40MHz  
 33-20LOG(f/50)dB MIN FROM 40.1MHz TO 100MHz  
 COMMON MODE REJECTION RATIO (CMRR): 30dB MIN FROM 0.5MHz TO 100MHz  
 ISOLATION VOLTAGE: 2250VDC(MAX) FOR 60 SECONDS WITH A RISE TIME OF  
 500V/SEC AND WITH ALL PORTS CONNECTED.
- PART NUMBER, DATE CODE AND COUNTRY OF ORIGIN ARE LOCATED  
 IN APPROXIMATE AREA SHOWN. DATE CODE "YY" IS YEAR, "WW" IS  
 WORK WEEK, "D" IS DAY OF WEEK, WITH SUNDAY=1
- TRP LOGO AND AGENCY APPROVAL LOGO ARE  
 LOCATED IN APPROXIMATE AREA SHOWN.
- OPERATING TEMP: FROM 0°C TO +70°C.
- RJ45 CAVITY CONFORMS TO FCC RULES AND REGULATION PART 68 SUBPART F.
- INDICATED MAGNETIC CONNECTIONS ARE SYMMETRICAL AND  
 SUPPORT AUTO-MDI/MDIX.
- DATUM AND BASIC DIMENSION ESTABLISHED BY CUSTOMER.
- BASIC DIMENSION ESTABLISHED BY CUSTOMER, BUT MAY NOT BE  
 GREATER THAN 5.08mm.
- THE PARTS ARE RECOMMENDED FOR WAVE SOLDERING PROCESS,  
 PEAK TEMPERATURE 260°C MAX, 10 SECONDS MAX.

### S8G69P6 GIGABIT CIRCUIT

TOP AND BOTTOM PORTS

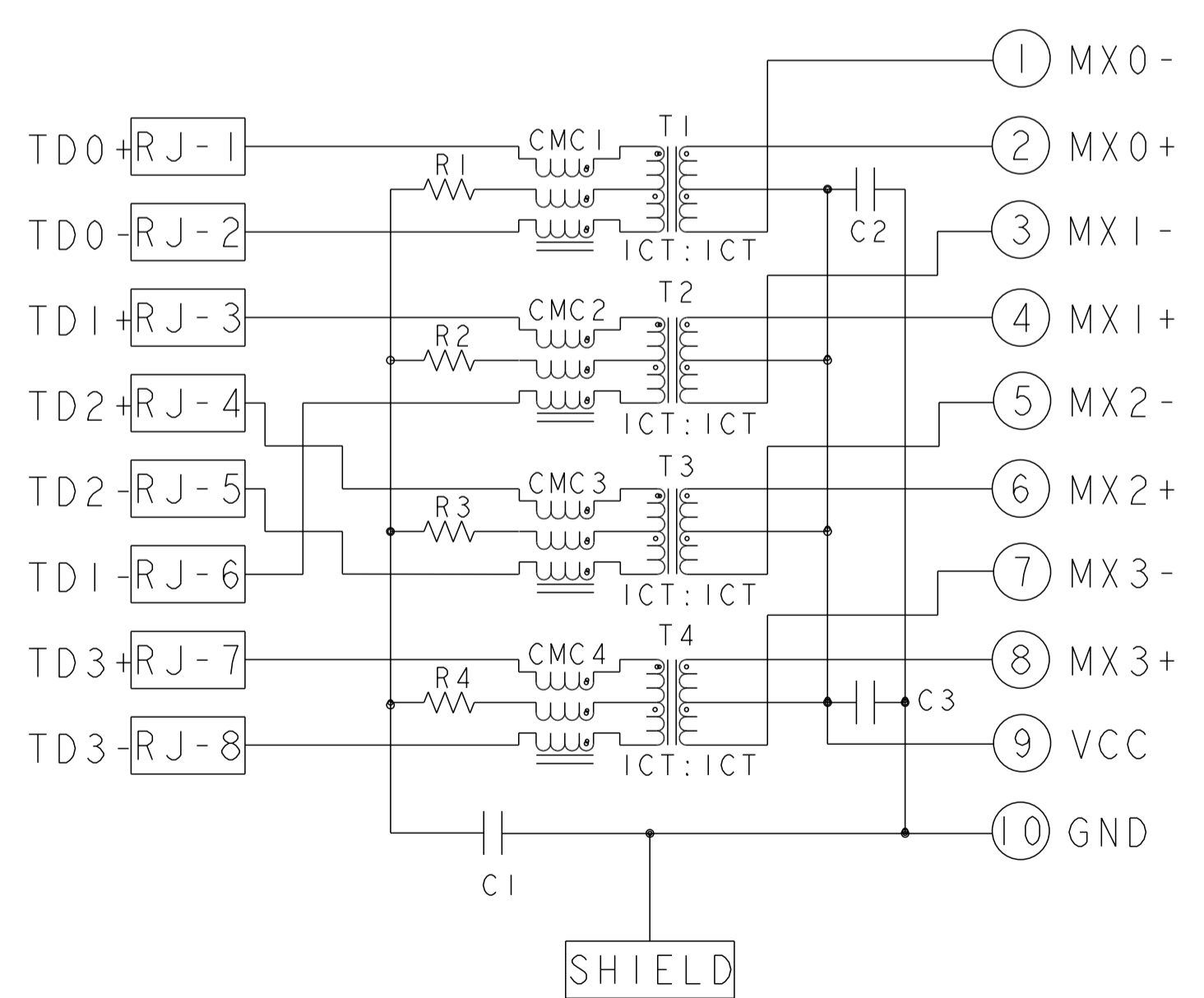

#### Pin Designations

(Repeat for each vertical pair of ports.)

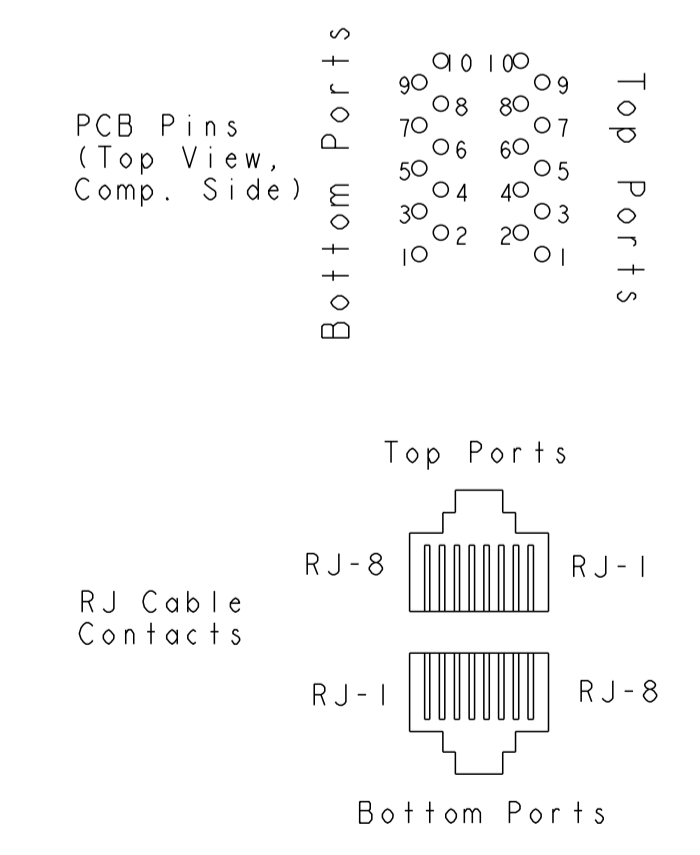

C1: 1000PF, 2KV CAPACITOR  
 C2 - C3 : 10nF, 50V CAPACITOR  
 R1-R4: 75 Ohms, RESISTORS

2.29	1840337-2
3.04	1840337-1
DIM A	PART NUMBER

THIS DRAWING IS A CONTROLLED DOCUMENT.		DRW: JAMISON C/SEAN H 27SEP2010	TRP CONNECTOR a bel group DONGGUAN CHINA
DIMENSIONS: mm		CHK: TONY YUAN 27SEP2010	
TOLERANCES UNLESS OTHERWISE SPECIFIED:		APPR: KEITH ZHU 27SEP2010	MODEL NAME: MAGJACK DESC: 2X8 S8G69P6 GIGABIT W/O LED
0 PLC ±0.25 1 PLC ±0.25 2 PLC ±0.25 3 PLC ±0.25 4 PLC ±		PRODUCT SPEC: 108-104004 APPLICATION SPEC:	SIZE: A1 CAGE CODE: 1840337 DRAWING NO: 1840337 RESTRICTED TO:
CUSTOMER DRAWING		SCALE: 4:1	SHEET 1 OF 3 REV C

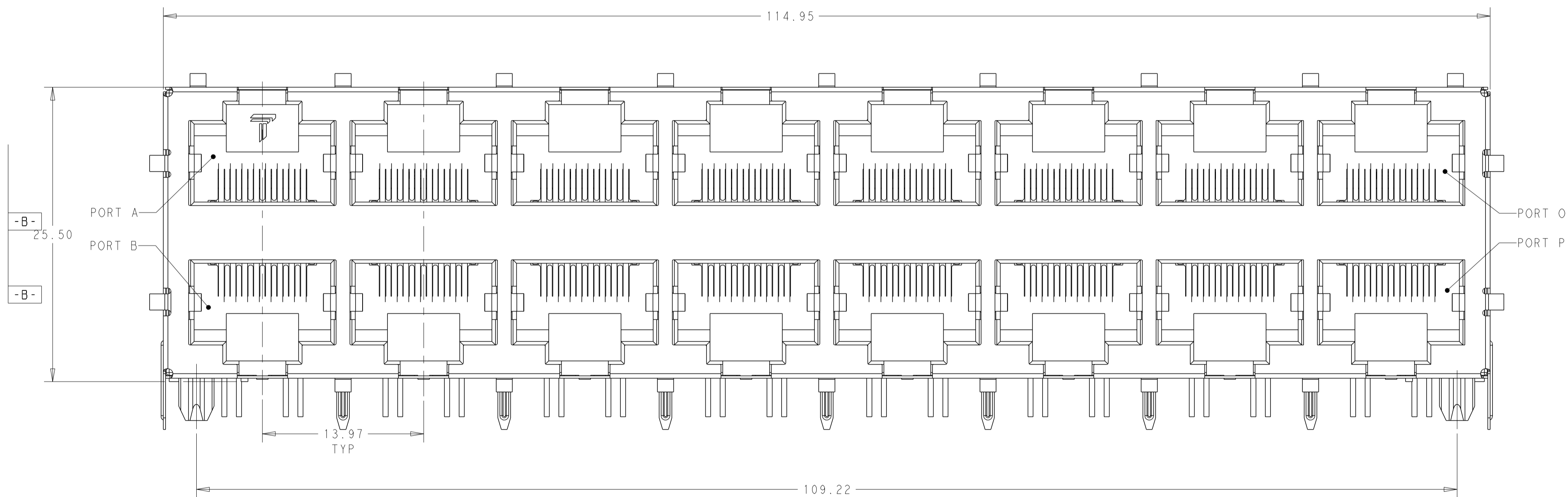
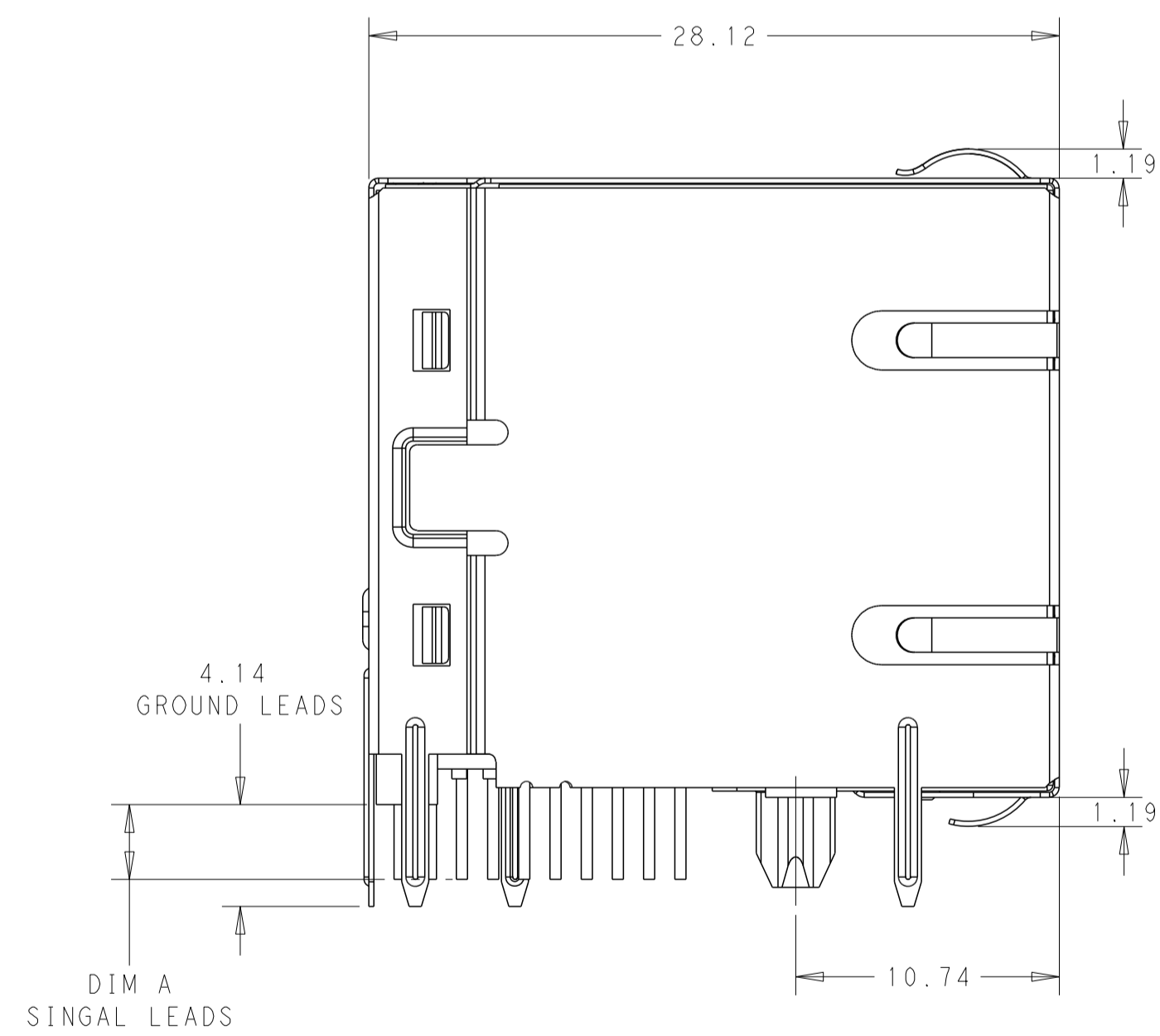
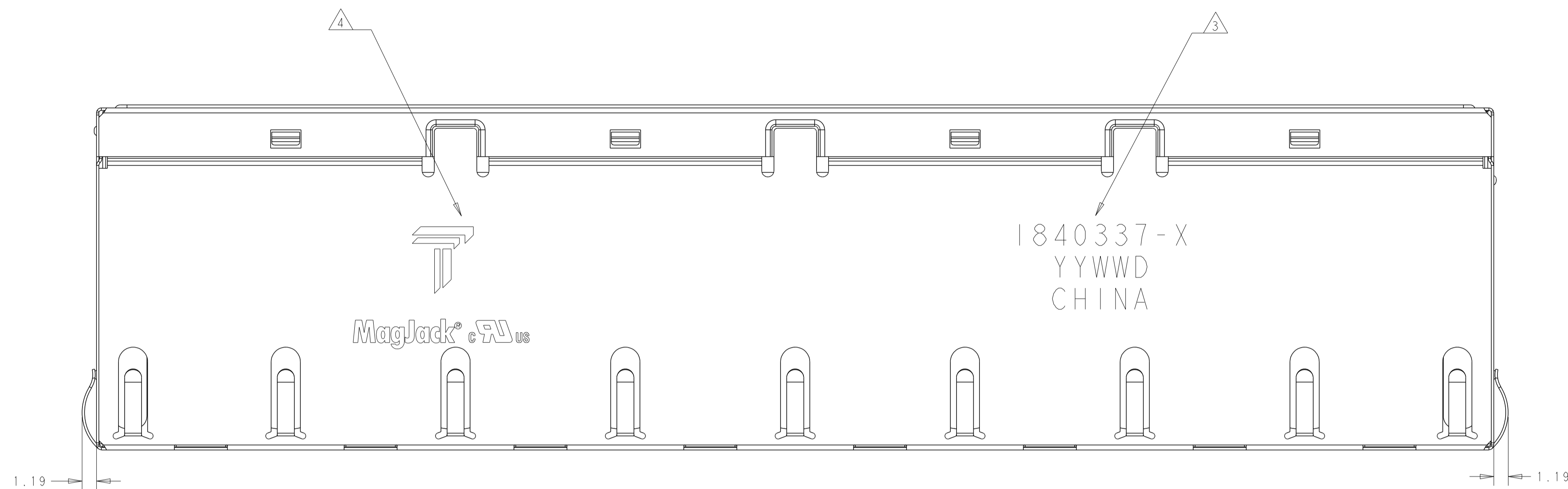

THIS DRAWING IS A CONTROLLED DOCUMENT.		DWN: JAMISON C/27SEP2010 CHK: TONY YUAN 27SEP2010 APD: KEITH ZHU 27SEP2010 MODEL NAME: MAGJACK	TRP CONNECTOR a bel group DONGGUAN CHINA
DIMENSIONS: mm 	TOLERANCES UNLESS OTHERWISE SPECIFIED: 0 PLC ±0.25 1 PLC ±0.25 2 PLC ±0.25 3 PLC ± 4 PLC ± ANGLES ± APPLICATION SPEC ±	DESC: 2X8 S8G69P6 GIGABIT W/O LED SIZE: A1 CAGE CODE: 1840337 DRAWING NO: 1840337 RESTRICTED TO: - CUSTOMER DRAWING	
PRODUCT SPEC: 108-104004		SCALE: 4:1 SHEET: 2 OF 3 REV: C	

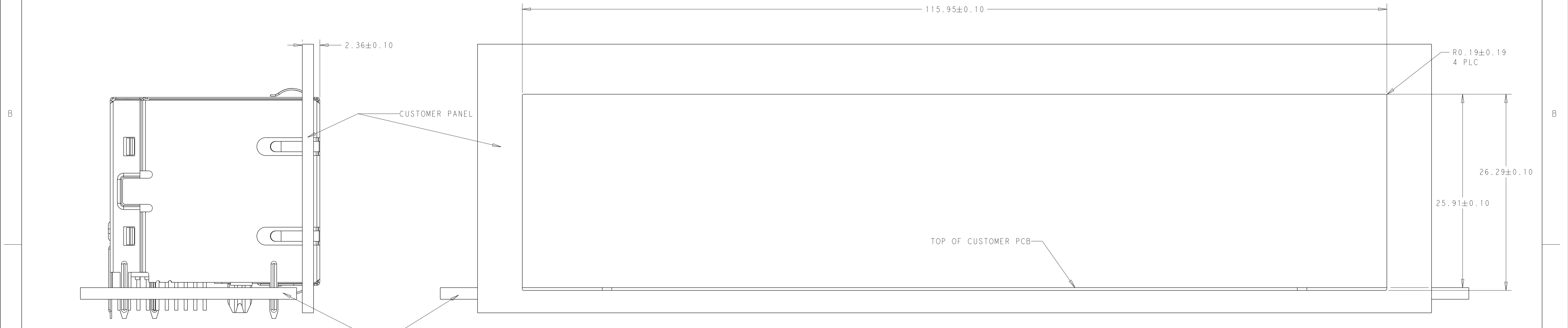
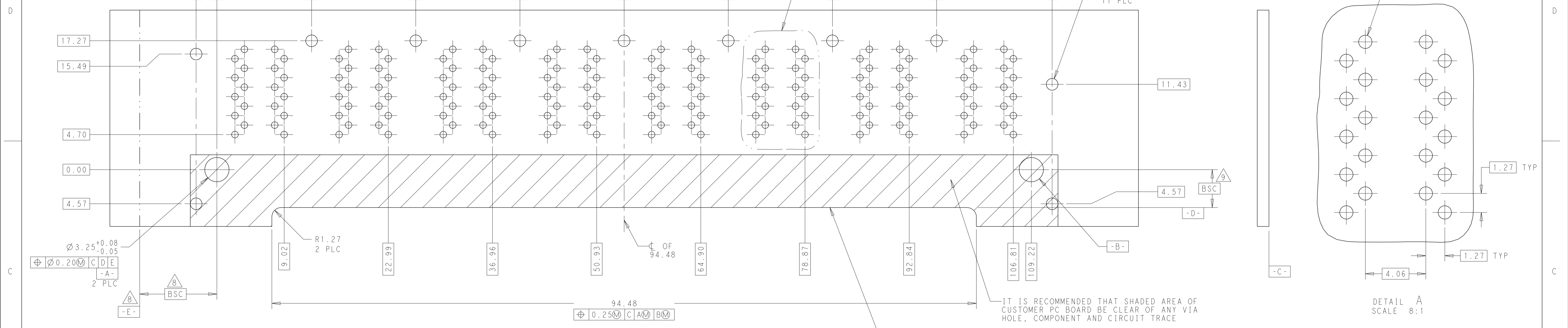

THIS DRAWING IS A CONTROLLED DOCUMENT.		DRW: JAMISON C/SEAN H 27SEP2010	<b>trp</b> CONNECTOR a bel group DONGGUAN CHINA
DIMENSIONS: mm		CHK: TONY YUAN 27SEP2010	
		APP'D: KEITH ZHU 27SEP2010	
TOLERANCES UNLESS OTHERWISE SPECIFIED:		MODEL NAME: MAGJACK	DESC: 2X8 S8G69P6 GIGABIT W/O LED
0 PLC ±0.25 1 PLC ±0.25 2 PLC ±0.25 3 PLC ± 4 PLC ± ANGLES ± APPLICATION SPEC ±		SIZE: A1	RESTRICTED TO: -
PRODUCT SPEC: 108-104004		STAG: STACK Non-PoE	CAGE CODE: 1840337
CUSTOMER DRAWING		SCALE: 4:1	SHEET 3 OF 3 REV C