

DC Electronic Circuit Protector (24 VDC 4 Outputs/8 Outputs Type)

S8V-CP

Simplified safety design of DC circuits
Reliable DC circuit protection in the event of short circuits or overcurrent
Saves space even with multi-channels
Sequential start-up of outputs to avoid start-up trouble



NEW

- Push-in plus terminal block adopted
- Push button with indicator to help you understand each output status at a glance
- Switch lets you set the rated output current appropriately for each output depending on load
- Lineup of a UL Class 2 output-compatible model

For the most recent information on models that have been certified for safety standards, refer to your OMRON website.

Refer to *Safety Precautions* on page 10.

Model Number Structure

Model Number Legend Not all combinations are possible. Refer to List of Models in Ordering Information, below.

S8V-CP **24**
Series name (1) (2) (3)

(1) Number of Outputs

Code	Number of Outputs
04	4 outputs
08	8 outputs

(2) Rated input voltage

Code	Rated input voltage
24	24 VDC

(3) UL Class 2 output

Code	UL Class 2 output certified
S	Yes
No	No

List of Models

Unit

Number of Outputs	UL Class 2 output	Model
4 outputs	No	S8V-CP0424
	Yes	S8V-CP0424S
8 outputs	No	S8V-CP0824

S8V-CP

Ratings, Characteristics, and Functions

Item	Model		S8V-CP0424	S8V-CP0424S	S8V-CP0824
	Number of Outputs		4	4	8
	UL Class 2 output		No	Yes	No
I/O characteristics	Rated input voltage (Input voltage allowable range)		24 VDC (20 to 30 VDC)	24 VDC (20 to 28.8 VDC)	24 VDC (20 to 30 VDC)
	Allowable input current *1		40 A	15.2 A	70 A
	Max. rated output current (per output)		10 A	3.8 A	10 A
	Internal voltage drop *2		180 mV typ.	180 mV typ.	200 mV typ.
	Output leakage current		10 mA max.		
	Power consumption (at input voltage 24 VDC) *3	When all outputs are connected	8 W typ. (at 10 A x 4 CH)	4 W typ. (at 3.8 A x 4 CH)	15 W typ. (at 10 A x 7 CH)
		When all outputs are tripped	0.7 W typ.	0.8 W typ.	1.1 W typ.
Start-up time *4	Initialization time	250 ms typ.			
	Start-up delay time	50 ms to 5 s			
Functions *5	Current tripping function *6	Rated output current	2 A, 3 A, 4 A, 6 A, 8 A, 10 A	3.8 A	2 A, 3 A, 4 A, 6 A, 8 A, 10 A
		Cutoff current	2.5 A, 3.5 A, 4.5 A, 6.5 A, 8.5 A, 10.5 A	3.8 A	2.5 A, 3.5 A, 4.5 A, 6.5 A, 8.5 A, 10.5 A
	Over voltage tripping function *6		No	Yes	No
	Push button (ON/OFF/RESET) with indicator		Yes (LED colors: Red/Green/Yellow)		
	Reset signal input (RST)		Yes (High level: 20 to 30 VDC, Low level: 0 to 5 VDC)		
Insulation	Alarm signal output (ALM1/ALM2)		Yes (MOS FET relay output 30 VDC max., 50 mA max.)		
	Dielectric strength		1.0 kVAC for 1 min (between all terminals and DIN rail mounting parts), current cutoff 20 mA		
Environment	Insulation resistance		100 MΩ min. (between all terminals and DIN rail mounting parts) at 500 VDC		
	Ambient operating temperature		-25 to 70°C (Derating is required according to the temperature.) (with no condensation or icing)		
	Storage temperature		-40 to 85°C (with no condensation or icing)		
	Ambient operating humidity		5% to 96% (storage humidity: 5% to 96%)		
Reliability	Vibration resistance		10 to 55 Hz, maximum 5 G, 0.42 mm half amplitude for 2 h each in X, Y, and Z directions		
	Shock resistance		294 m/s ² , 3 times each in ±X, ±Y, ±Z directions		
	MTBF *7	135,000 hrs typ.	60,000 hrs typ.	60,000 hrs typ.	
Construction	Life expectancy *8		10 years min.		
	Weight		160 g max.	170 g max.	420 g max.
	Cooling fan		No		
Standards	Degree of protection		IP20 by IEC60529		
	EMI		Conforms to EN 61000-6-3		
	EMS		Conforms to EN 61000-6-2		
Safety standards		UL 508 (CSA22.2 No.14-10) Listing Pol2 UL 2367 Recognition (Max. 100W per output, per Class 2 limitations) Pol2 *9 CE (EN 61000-6-2, EN 61000-6-3)			

*1. For power input terminals, use 35 A max. per pole.

*2. A voltage drop will occur in the S8V-CP. Consider the voltage drop at the output.

*3. When selecting the power supply, be sure to include the power consumption of the S8V-CP and not just the power consumption of the load.

*4. Outputs start in order from +VO1 to +VO8. +VO1 starts after the initialization time. Start-up delay time of each output is automatically decided depending on the load. If the start-up delay time is over 5 s, the next output is forcibly started.

*5. Refer to *Tripping Functions* on page 3 for details.

*6. Refer to *Current Tripping Characteristics* and *Current and Voltage Tripping Characteristics* on page 7 for details.

*7. MTBF is calculated according to JEITA RCR-9102.

*8. Refer to *Recommended Replacement Periods* and *Periodic Replacement for Preventive Maintenance* on page 14 for details.

*9. UL Class 2 output applies for the S8V-CP0424S model only.

Tripping Functions

Current tripping

If the output current of each output exceeds the current tripping, the output is tripped by a semiconductor switch (MOS FET) in accordance with the current tripping characteristic.

Over voltage tripping

With the S8V-CP0424S, if the input voltage exceeds 28.8 V, all outputs are tripped by a semiconductor switch (MOS FET). If the input voltage becomes 28.8 V or less, all outputs automatically return to the previous state.

Reset Signal Input (RST)

Turning ON all outputs during in the Current tripping (enable to reset) state is called reset. All output terminals can be reset by an external input. As shown in the following figure, input a high level signal of 0.5 s or more and reset.

Input voltage: 30 VDC max.

Input impedance: 22 k Ω

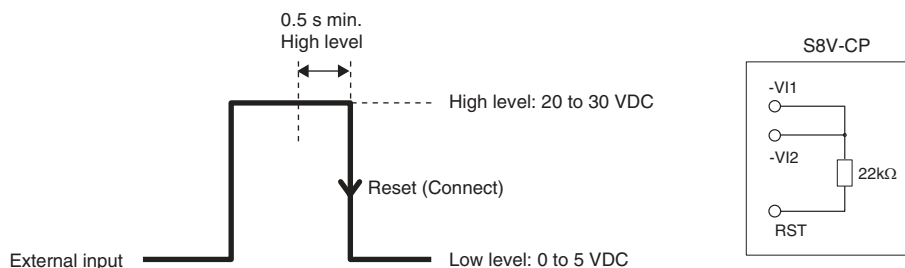

Note: 1. When Reset signal input terminal is used, a miss operation of reset may occur by a noise coming from the cable. Do not make an instable potential of Reset signal input terminal.

Alarm Signal Output (ALM1/ALM2)

If any of the output is tripped, the MOS FET relay is turned OFF. The signal output comprises of MOS FET relays and therefore, does not have polarity.

Input voltage: 30 VDC max., Input current: 50 mA max.

Residual voltage when ON: 2 V max.

Leakage current when OFF: 0.1 mA max.

Note: 1. Alarm signal output is not equipped with an internal current limiting circuit, so be sure that the current flowing to the alarm signal output terminals does not exceed 50 mA.

2. Be sure to check that the Alarm signal outputs are working normally after wiring.

Output Status

The status of each output can be identified by the indicator or alarm signal output.

The status of each output is saved when the power is turned OFF. When the power is turned ON again, the status transits to that saved after initialization.

All outputs are set to Output ON state by default.

Indicator		Alarm Signal Output	Output	Status Name	Status Transition by Push Button	Status Transition by Reset Signal Input
Color	Status					
---	OFF	OFF	OFF	Initialization	---	---
Green	ON	ON	ON	Output ON	Manually output OFF	---
Yellow	ON	ON	ON	Over current *1	Manually output OFF	---
Red	ON	OFF	OFF	Manually output OFF	Output ON	---
Red	Blinking	OFF	OFF	Current tripping (Disable to reset) *2	---	---
Yellow	Blinking	OFF	OFF	Current tripping (Enable to reset)	Manually output OFF	Output ON (transition due to positive pulse longer than 0.5 s) *5
Red	Blinking fast	OFF	OFF	Over voltage tripping *3 Internal error detection *4	---	---

*1. Each output transits automatically to Current tripping (disable to reset) state according to the Current tripping characteristics.

*2. The status remains on Current tripping (disable to reset) state during 500 ms to 20 s in order to protect the internal parts from heat. After that, the status automatically transits to Current tripping (enable to reset) state.

*3. S8V-CP0424S only

*4. If an internal fuse blows, or an internal memory error occurs, the output will be disconnected.

*5. Always remove the cause of the output first and then reset the alarm when abnormal tripping operates.

S8V-CP

Connections

Block Diagrams

S8V-CP0424

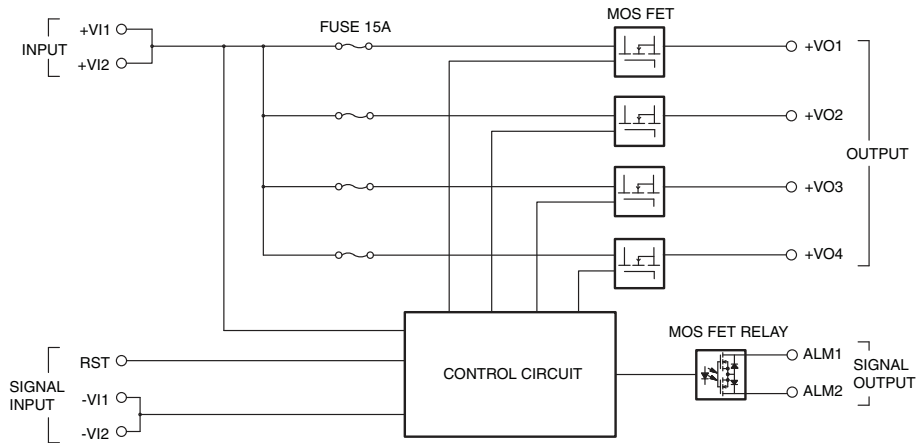

S8V-CP0424S

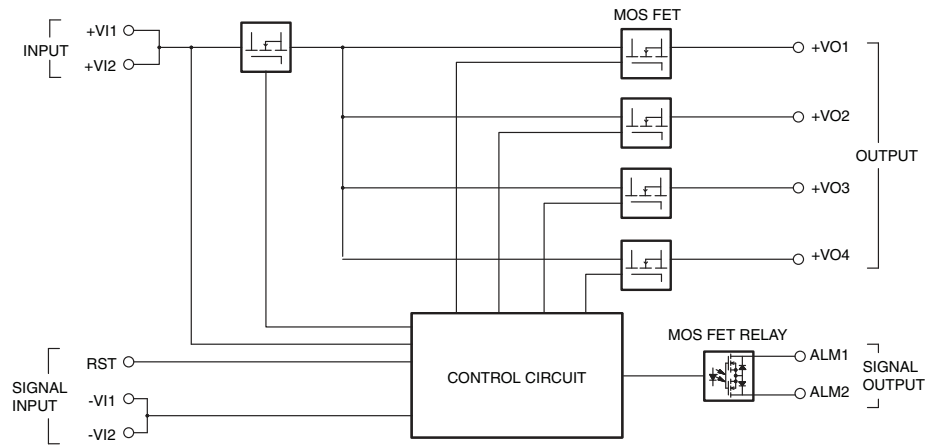

S8V-CP0824

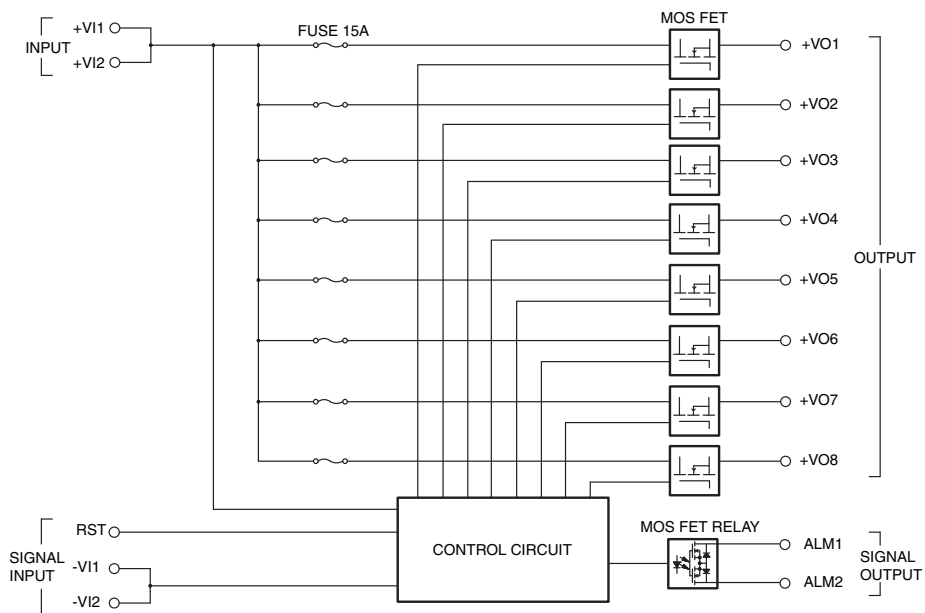

Connection Example

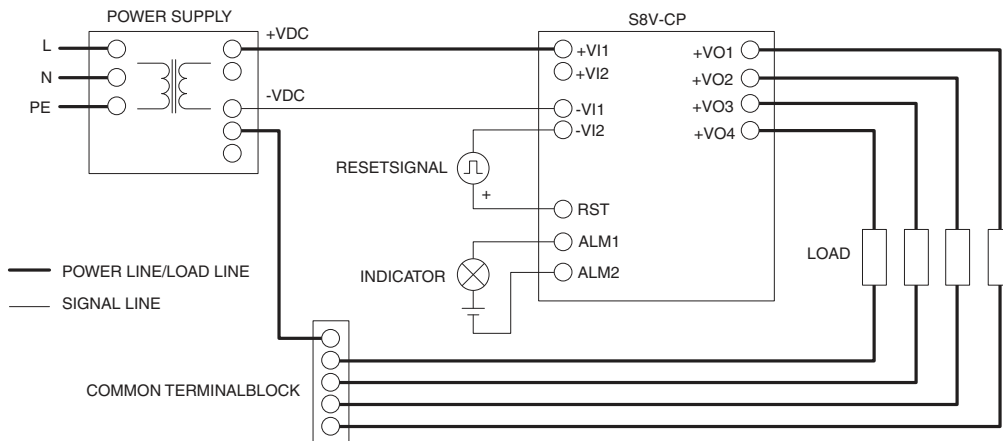

- Note:** 1. Wire so that the load current does not flow into -VI1 or -VI2.
 2. Follow the figures below for wiring Reset signal input terminal.

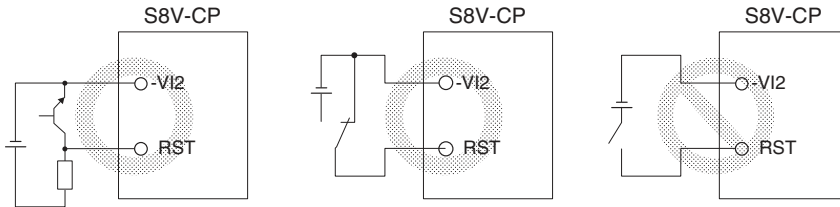

S8V-CP

Construction and Nomenclature

Nomenclature

4 outputs type S8V-CP0424

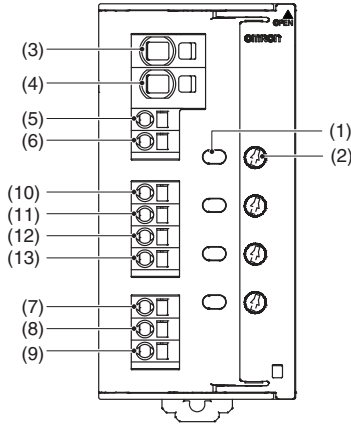

S8V-CP0424S

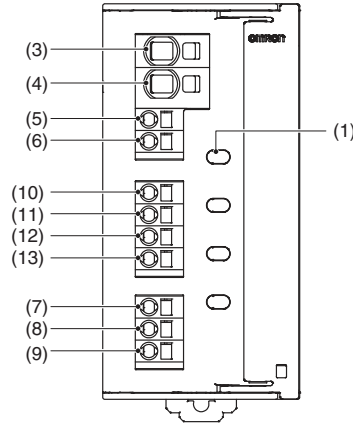

8 outputs type S8V-CP0824

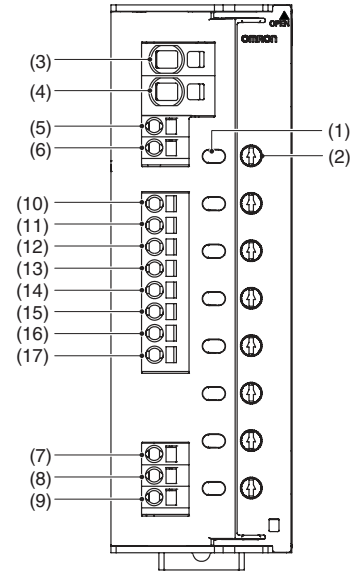

No.	Terminal name	Name	Function
1	---	Push button (ON/OFF/RESET) with indicator	The indicator shows the connected/tripped status of each output. The push button switch is used to switch between the connected/tripped status of each output.
2	---	Rated output current selector switch	Changes the rated output current of each output with the rotary switch. *1
3	INPUT	+VI1	Power input terminals
4		+VI2	
5	SIGNAL INPUT	-VI1	Negative input terminal
6		-VI2	
7		RST	Reset signal input terminal
8	SIGNAL OUTPUT	ALM1	Alarm output terminal
9		ALM2	
10	OUTPUT	+VO1	Output terminal *3
11		+VO2	
12		+VO3	
13		+VO4	
14		+VO5	
15		+VO6	
16		+VO7	
17		+VO8	
			Connects the positive side of the load line.

*1. Use a flathead screwdriver to change position of the switch.

*2. Do not connect the load wire to the Negative input terminal.

*3. +VO5 to +VO8 are only in the S8V-CP0824.

Engineering Data

Derating Curves

S8V-CP0424

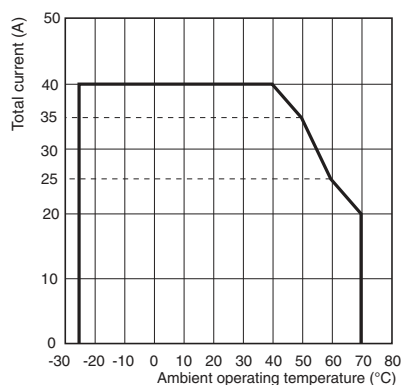

S8V-CP0424S

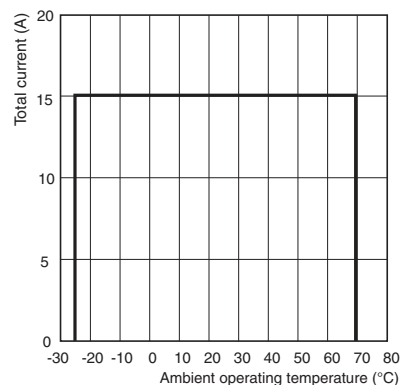

S8V-CP0824

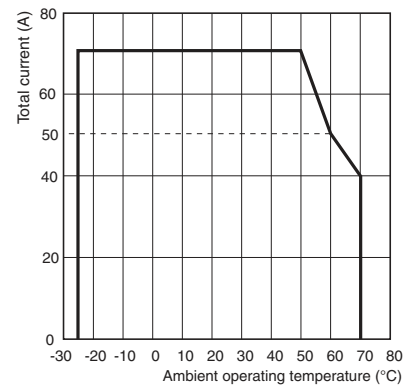

Current Tripping Characteristics

S8V-CP0424, S8V-CP0824

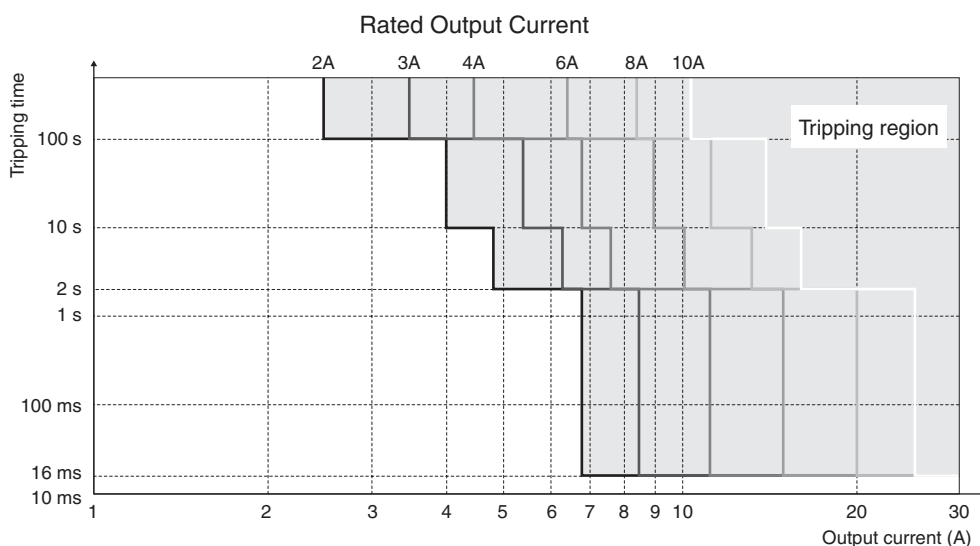

Note: If the power rating of the power supply unit is insufficient, the overcurrent protection characteristic can cause a voltage drop in all the outputs. In order to trip the current according to the above characteristic, select a power supply unit with a current higher than the total tripping current considering the power consumption of the S8V-CP.

Current and Voltage Tripping Characteristics

S8V-CP0424S

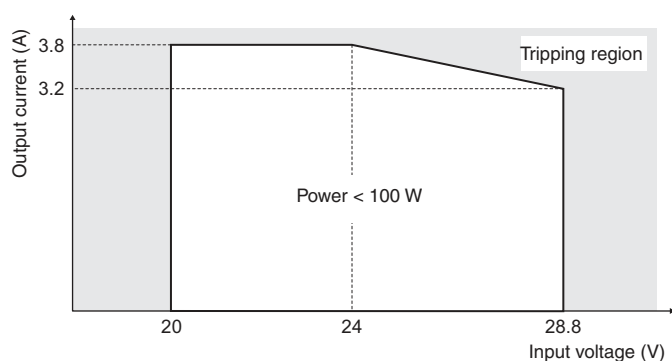

- Note:** 1. Input voltage 24 to 28.8 VDC tripping current is decreased to less than 3.2 A in accordance with the current and voltage tripping characteristic.
- 2. Current tripping takes place between 250 ms to 5 s.

S8V-CP

Dimensions

(Unit: mm)

Unit

S8V-CP0424

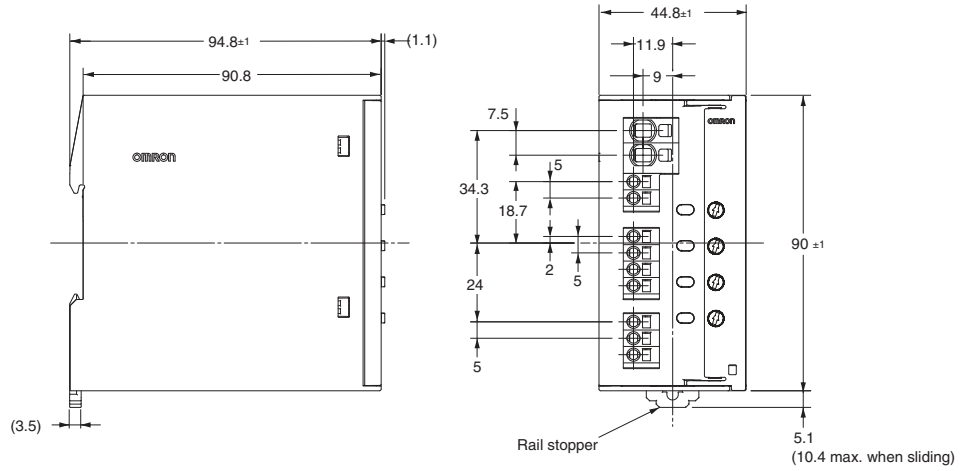

S8V-CP0424S

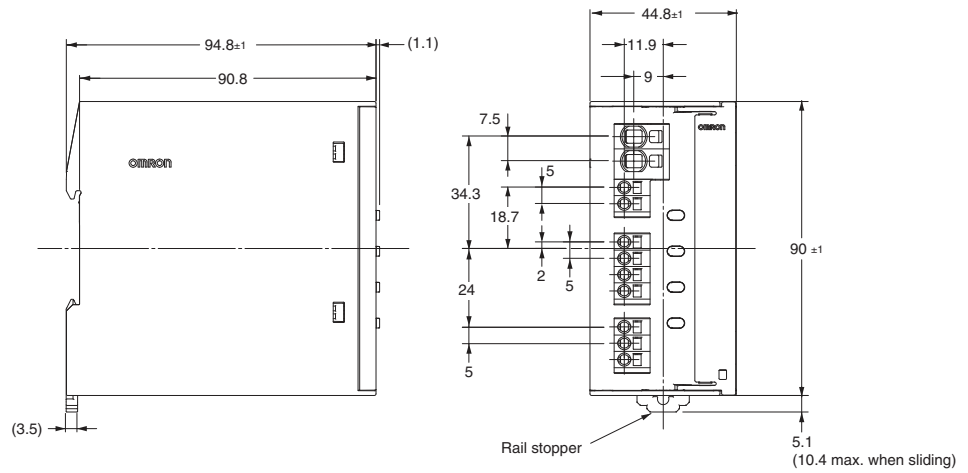

S8V-CP0824

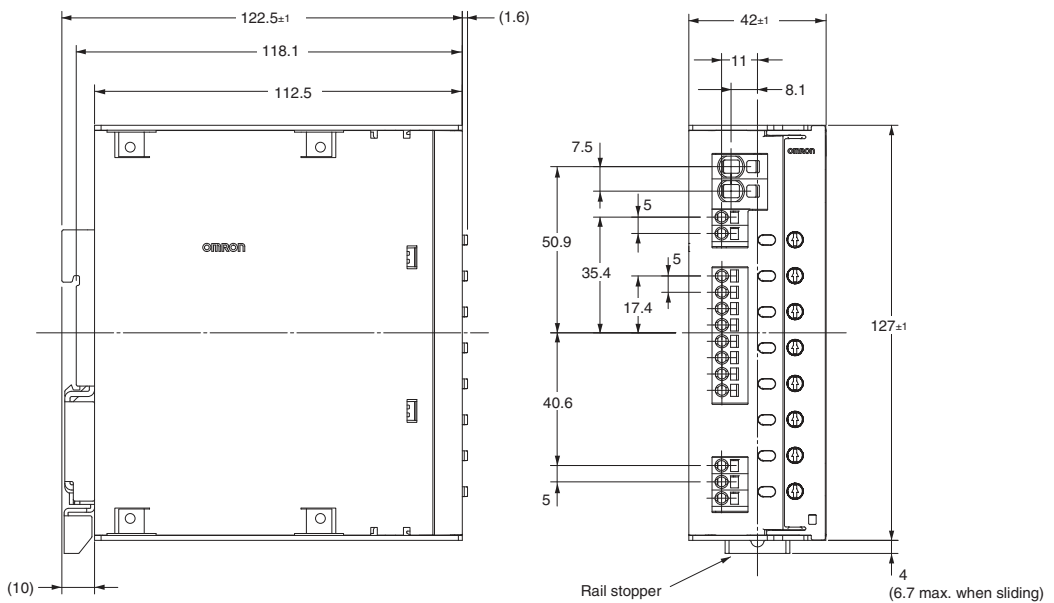

DIN Rail Mounting (Order Separately)

Mounting Rail (Material: Aluminum)

PFP-100N
PFP-50N

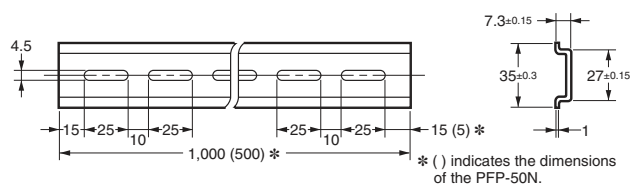
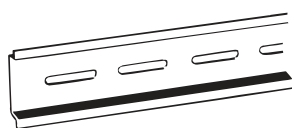

Mounting Rail (Material: Aluminum)

PFP-100N2

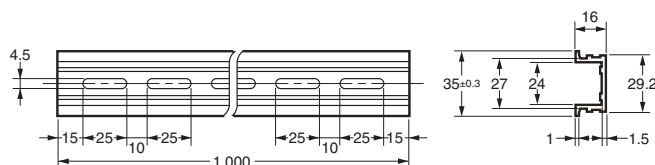
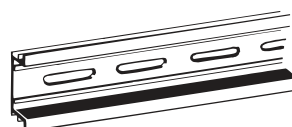

End Plate

PFP-M

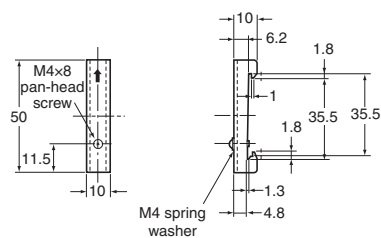
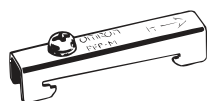

Note: If there is a possibility that the Unit will be subject to vibration or shock, use a steel DIN Rail. Otherwise, metallic filings may result from aluminum abrasion.



Safety Precautions

Be sure to read the precautions for all models in the website at: <http://www.ia.omron.com/>.

Warning Indications

 CAUTION	Indicates a potentially hazardous situation which, if not avoided, may result in minor or moderate injury or in property damage.
Precautions for Safe Use	Supplementary comments on what to do or avoid doing, to use the product safely.
Precautions for Correct Use	Supplementary comments on what to do or avoid doing, to prevent failure to operate, malfunction or undesirable effect on product performance.

Meaning of Product Safety Symbols

	Caution against electric shock Used to warn of the risk of electric shock under specific conditions.
	Caution against high temperatures Used to warn of the risk of minor injury caused by high temperatures.
	General instructions Used for general mandatory action precautions for which there is no specified symbol.

CAUTION

If a wire is disconnected, electric shock may result. Insert the solid wire or ferrule straight into the terminal block until the end touches the terminal block.



Minor burns may occasionally occur. Do not touch the Product while power is being supplied or immediately after power is turned OFF.



Minor electric shock, fire, or Product failure may occasionally occur. Do not allow any pieces of metal, conductors, or cuttings from installation work to enter the Product.



The Product will be damaged. Do not incorrectly connect the polarity of power input terminals.



Fire, or Product failure may occasionally occur. Do not apply voltages that exceed the input voltage allowable range.



Unexpected output may occasionally occur. Be careful sufficiently not to accidentally press the push button with indicator during Manually output OFF state.



Precautions for Safe Use

Ambient Operating and Storage Environments

- Store the Product at a temperature of -25 to 85°C and a humidity of 5 to 96%.
- The internal parts may occasionally deteriorate or be damaged. Do not use the Product in areas outside the derating curves.
- Use the Product at a humidity between 5 to 96%.
- Do not use the Product in locations subject to direct sunlight.
- Do not use locations where liquids, foreign matter, or corrosive gases may enter the interior of the Product.
- If the Product has been accidentally dropped, do not use it as its internal parts may be damaged.
- Minor electric shock, fire, or Product failure may occasionally occur. Do not disassemble, modify, or repair the Product or touch interior of the Product.

Installation Environment

- Do not use the Product in locations subject to shocks or vibrations. In particular, install the product as far away as possible from contactors or other devices that are a vibration source. Be sure to mount End Plates (PFP-M) on both ends of the Product.
- Install the Product well away from any sources of strong, high-frequency noise and surge.

Mounting

- Take adequate measures to ensure proper heat dissipation to increase the long-term reliability of the Product. Mount the Product so that air convection will occur around it. Use it in areas within the derating curves (see *Derating Curves* on page 7).
- The internal parts may occasionally deteriorate and be broken due to adverse heat radiation. Do not loosen the screws on the Product.
- Mount as shown below.

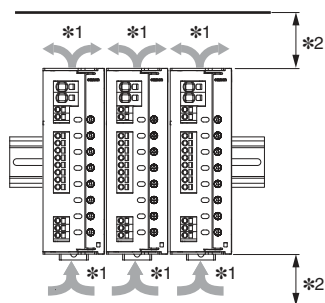

- *1. Direction of air circulation
- *2. Space above and below the Product: 25 mm min. (S8V-CP0424□)
Space above and below the Product: 20 mm min. (S8V-CP0824)

- Only products of the same model can be combined and used if the horizontal separation is less than 15 mm.

Wiring

- The property damage may occasionally occur due to fire. If the insertion distance is not sufficient. When wiring, insert the wiring material securely all the way in.
- Minor fire may possibly occur. Ensure that input and output terminals are wired correctly.
- Do not apply more than 40 N force to the terminal block when inserting wiring or inserting a flat-blade screwdriver into the release hole.
- Do not wire anything to the release holes.
- Do not tilt or twist a flat-blade screwdriver while it is inserted into a release hole on the terminal block. The terminal block may be damaged.
- Insert a flat-blade screwdriver into the release holes at an angle. The terminal block may be damaged if you insert the screwdriver straight in.
- Do not allow the flat-blade screwdriver to fall out while it is inserted into a release hole.
- Do not bend a wire past its natural bending radius or pull on it with excessive force. Doing so may cause the wire to break.
- Do not insert more than one wire into each terminal insertion hole.
- Do not pre-solder the ends of the wires. Doing so will inhibit proper connection.
- If there is a possibility that the Unit will be subject to vibration or shock, use Wires with Ferrules or Stranded Wires.
- Be sure to remove the sheet covering the product before Turn ON so that it does not interfere with heat dissipation.
- To prevent wiring materials from smoking or ignition, confirm wire ratings and use the wiring materials given in the following table.

Recommended Wire

Terminal	Recommended wire gauge	
	(mm ²)	(AWG)
Power input terminals	0.25 to 6	24 to 10
Output terminals, Negative input terminal, Reset signal input terminal, Alarm output terminal	0.25 to 2.5	24 to 14

- Use copper stranded wire or solid wire.
- Do not use the solid wire to the power input terminal.
- Use min. 75°C wire.
- Input crossover wiring can be used for the input side of the Product. If you use crossover wiring for N number of the Products, a current that is N times the current for a standalone the Unit may flow to the input terminals. Take this into consideration when you select wiring materials.
- Make sure that the current of the power input terminal does not exceed 35A per pole.
- When connecting to the two poles of the power input terminals, be sure that the length and thickness of wires are the same to allow for well balanced current flows.

Stripping length

Applicable to all the terminal blocks

Recommended Wire Type	Stripping length (Ferrules not used)
0.25 to 2.5 mm ² /AWG 24 to 14	10 mm

Power input terminal block

Recommended Wire Type	Stripping length (Ferrules not used)
4 to 6 mm ² /AWG 12 to 10	15 mm

Input Voltage

- The S8V-CP0424S provides over voltage tripping function. All outputs will be tripped if the input voltage exceeds 28.8 VDC. However, this function does not protect loads and internal parts from high voltages in all cases. Use the input voltage within the rated range.
- The S8V-CP0424S may operate the over voltage tripping for loads that generate reverse peak electromotive force.
- The S8V-CP operates by DC input. Do not connect an AC power source to the power input terminal.

Input Power Supply Selection

- Depending on the overcurrent protection characteristics of the power supply connected to the input side can cause the failure of S8V-CP operating or tripping by voltage drop occasionally.
- If the input power supply starts or stops too slowly, the overcurrent protection characteristics of the power supply can cause the failure of S8V-CP operating or tripping by voltage drop occasionally.

Tripping Performance

- Always remove the cause of the output first and then reset the alarm when current tripping operates.
- When using a load that operates with constant power, the current may be tripping when the power is turned OFF.
- Do not repeat the tripping and reset operations more than necessary. Internal parts may possibly deteriorate or be damaged.
- Tripping performance depends on the ambient operating temperature. Use the Product within the derating curve (see *Derating Curves* on page 7).
- Internal parts may possibly deteriorate or be damaged. Do not use the Product for applications with frequent inrush current or overloading at the load end.

Dielectric Strength Test

- Always short the all terminals of the Product so that the voltage is applied at the same time.
- There is no insulation between the power input terminal and the output terminal. Do not perform dielectric strength tests or other insulation appraisal testing between inputs and outputs.

Connecting the S8V-CP

It is possible to connect multiple units of this Product as shown below.

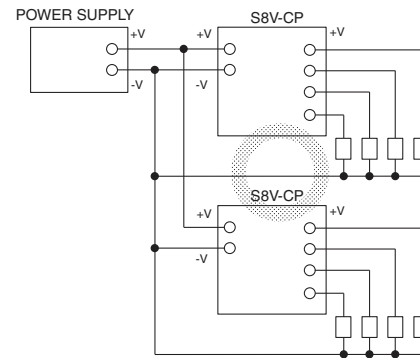

Serial connections, such as connecting an S8V-CP to the output terminal of another S8V-CP, can not be established.

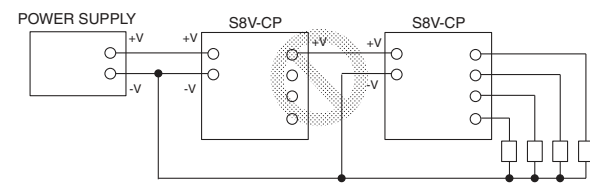

Do not establish a parallel connection with other outputs. Also, do not establish a parallel connection between the output terminals of two S8V-CP.

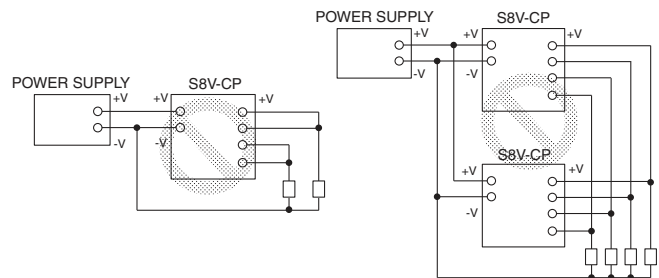

Rated output current selector switch

The rated output current selector switch may possibly become damaged. Do not apply more than the required force.

Precautions for Correct Use

Connecting Backup Devices

Observe the following precautions when using a backup device, such as one from OMRON's S8T Series.

- When a backup device is connected to the S8V-CP output, backup current is supplied to the other output through the internal circuit, and at the same time, internal components may be degraded or damaged. When you use a backup device together, be sure to connect it to the power input side of the S8V-CP.
- If you connect the backup device to the S8V-CP input terminal, the backup time will be shorter than usual due to the consumption of internal power. Always confirm the backup time when using a backup device.

DIN rail mounting

S8V-CP0424/S8V-CP0424S

To mount the Product to a DIN rail, pull down the rail stopper until you hear it clicks open, hook portion (A) of the Product onto the DIN rail, press the Product in direction (B), and then push up the rail stopper to lock the Product in place.

S8V-CP0824

To mounting on a DIN Rail, hook portion (A) of the Block onto the rail and press in the (B) direction.

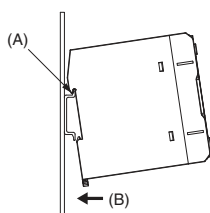

To dismantle the Block, pull down portion (C) with a flat-blade screwdriver and pull out the Block.

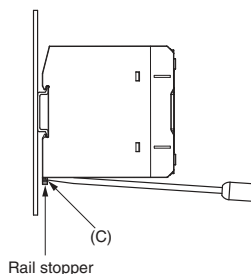

Connecting Wires to the Push-In Plus Terminal Block

Part Names of the Terminal Block

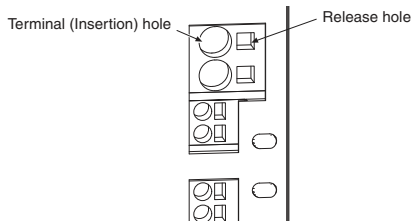

Connecting Wires with Ferrules and Solid Wires

Insert the solid wire or ferrule straight into the terminal block until the end touches the terminal block.

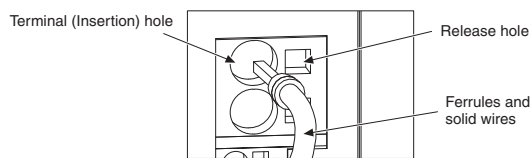

- If a wire is difficult to connect because it is too thin, use a flat-blade screwdriver in the same way as when connecting stranded wires.

Connecting Stranded Wires

Use the following procedure to connect the wires to the terminal block.

1. Hold a flat-blade screwdriver at an angle and insert it into the release hole. The angle should be between 10° to 15°. If the flat-blade screwdriver is inserted correctly, you will feel the spring in the release hole.
2. With the flat-blade screwdriver still inserted into the release hole, insert the wire into the terminal hole until it strikes the terminal block. Always twist stranded wires together before inserting them.
3. Remove the flat-blade screwdriver from the release hole.

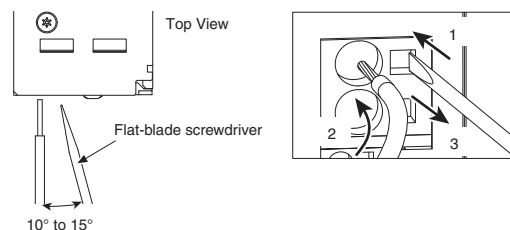

Checking Connections

- After the insertion, pull gently on the wire to make sure that it will not come off and the wire is securely fastened to the terminal block
- If you use the recommended ferrule, part of the conductor may be visible after the ferrule is inserted into the terminal block, but the Product insulation distance will still be satisfied.

Removing Wires from the Push-In Plus Terminal Block

Use the following procedure to remove wires from the terminal block. The same method is used to remove stranded wires, solid wires, and ferrules.

1. Hold a flat-blade screwdriver at an angle and insert it into the release hole.
2. With the flat-blade screwdriver still inserted into the release hole, remove the wire from the terminal insertion hole.
3. Remove the flat-blade screwdriver from the release hole.

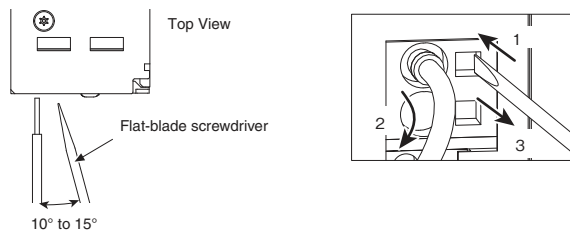

Recommended Ferrules and Crimping Tools

Recommended Ferrules

Applicable to all the terminal blocks

Applicable wire		Ferrule Conduct or length (mm)	Stripping length (mm) (Ferrules used)	Recommended Ferrules		
(mm ²)	(AWG)			Phoenix Contact	Weid muller	Wago
0.25	24	8	12	AI 0,25-8	H0.25/12	FE-0.25-8N-YE
		10	12	AI 0,25-10	---	---
0.34	22	8	12	AI 0,34-8	H0.34/12	FE-0.34-8N-TQ
		10	12	AI 0,34-10	---	---
0.50	20	8	12	AI 0,5-8	H0.5/14	FE-0.5-8N-WH
		10	12	AI 0,5-10	H0.5/16	FE-0.5-10N-WH
0.75	18	8	12	AI 0,75-8	H0.75/14	FE-0.75-8N-GY
		10	12	AI 0,75-10	H0.75/16	FE-0.75-10N-GY
1/1.25	18/17	8	12	AI 1-8	H1.0/14	FE-1.0-8N-RD
		10	12	AI 1-10	H1.0/16	FE-1.0-10N-RD
1.25/1.5	17/16	8	12	AI 1,5-8	H1.5/14	FE-1.5-8N-BK
		10	12	AI 1,5-10	H1.5/16	FE-1.5-10N-BK
2.5	14	10	12	AI 2,5-10	H2.5/16DS	FE-2.5-10N-BU
Recommended crimp tool				CRIMPFOX6 CRIMPFOX6T-F CRIMPFOX10S	PZ6 roto	Variocrimp4

- Note:** 1. Make sure that the outer diameter of the wire is smaller than the inner diameter of the insulating sleeve of the recommended ferrule.
2. Make sure that the ferrule processing dimensions conform to the following figure.

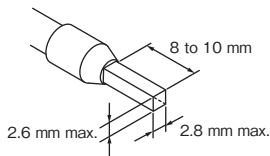

Power input terminal block

Applicable wire		Ferrule Conduct or length (mm)	Stripping length (mm) (Ferrules used)	Recommended Ferrules		
(mm ²)	(AWG)			Phoenix Contact	Weid muller	Wago
4	12	12	14	AI 4-12	H4.0/20D	FE-4.0-12N-GY
6	10	12	16	AI 6-12	H6.0/20	FE-6.0-12N-YE *
Recommended crimp tool				CRIMPFOX6 CRIMPFOX6T-F CRIMPFOX10S	PZ6 roto	Variocrimp4 * Use the Variocrimp16.

- Note:** 1. Make sure that the outer diameter of the wire is smaller than the inner diameter of the insulating sleeve of the recommended ferrule.
2. Make sure that the ferrule processing dimensions conform to the following figure.

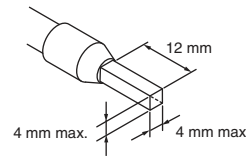

Recommended Flat-blade Screwdriver

Use a flat-blade screwdriver to connect and remove wires. Use the following flat-blade screwdriver. The following table shows manufacturers and models as of 2018/Dec.

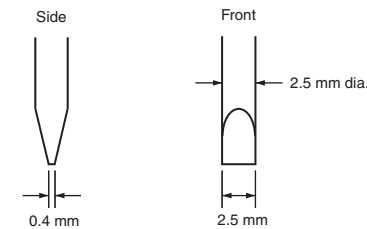

Model	Manufacturer
ESD 0,40x2,5	Wera
SZS 0,4x2,5 SZF 0-0,4x2,5 *	Phoenix Contact
0.4x2.5x75 302	Wiha
AEF.2,5x75	Facom
210/-719	Wago
SDIS 0.4x2.5x75	Weidmuller
9900 (-2.5x75)	VESSEL

* SZF 0-0,4X2,5 (manufactured by Phoenix Contact) is available to order as OMRON's exclusive purchase model (XW4Z-00B).

Recommended Replacement Periods and Periodic Replacement for Preventive Maintenance

The recommended replacement period for preventive maintenance is greatly influenced by the installation environment of the Power Supply. As a guideline, the recommended replacement period is 7 to 10 years.* To prevent failures or accidents that can be caused by using a Power Supply beyond its service life, we recommend that you replace the Power Supply as early as possible within the recommended replacement period. However, bear in mind that the recommended replacement period is for reference only and does not guarantee the life of the Power Supply.

Many electronic components are used in the Power Supply and the Power Supply depends on the correct operation of these components to achieve the original Power Supply functions and performance. However, the influence of the ambient temperature on aluminum electrolytic capacitors is large, and the service life is reduced by half for each 10°C rise in temperature (Arrhenius law). When the capacity reduction life of the electrolytic capacitor is reached, the Power Supply failures or accidents may occur. We therefore recommend that you replace the Power Supply periodically to minimize product failures or accidents in advance.

* The recommended replacement period applies under the following conditions: rated input voltage, load rate of 50% max., ambient temperature of 40°C max., and the standard mounting method.

This product model is designed with a service life of 10 years minimum under the above conditions.

OMRON AUTOMATION AMERICAS HEADQUARTERS • Chicago, IL USA • 847.843.7900 • 800.556.6766 • automation.omron.com

OMRON CANADA, INC. • HEAD OFFICE

Toronto, ON, Canada • 416.286.6465 • 866.986.6766 • automation.omron.com

OMRON ELECTRONICS DE MEXICO • HEAD OFFICE

Ciudad de México • 52.55.5901.4300 • 01.800.386.6766 • mela@omron.com

OMRON ELECTRONICS DE MEXICO • SALES OFFICE

San Pedro Garza García, N.L. • 81.12.53.7392 • 01.800.386.6766 • mela@omron.com

OMRON ELECTRONICS DE MEXICO • SALES OFFICE

Eugenio Garza Sada, León, Gto • 01.800.386.6766 • mela@omron.com

OMRON ELETRÔNICA DO BRASIL LTDA • HEAD OFFICE

São Paulo, SP, Brasil • 55.11.2101.6300 • www.omron.com.br

OMRON ARGENTINA • SALES OFFICE

Buenos Aires, Argentina • +54.11.4521.8630 • +54.11.4523.8483
mela@omron.com

OTHER OMRON LATIN AMERICA SALES

+54.11.4521.8630 • +54.11.4523.8483 • mela@omron.com

Authorized Distributor:

Controllers & I/O

- Machine Automation Controllers (MAC) • Motion Controllers
- Programmable Logic Controllers (PLC) • Temperature Controllers • Remote I/O

Robotics

- Industrial Robots • Mobile Robots

Operator Interfaces

- Human Machine Interface (HMI)

Motion & Drives

- Machine Automation Controllers (MAC) • Motion Controllers • Servo Systems
- Frequency Inverters

Vision, Measurement & Identification

- Vision Sensors & Systems • Measurement Sensors • Auto Identification Systems

Sensing

- Photoelectric Sensors • Fiber-Optic Sensors • Proximity Sensors
- Rotary Encoders • Ultrasonic Sensors

Safety

- Safety Light Curtains • Safety Laser Scanners • Programmable Safety Systems
- Safety Mats and Edges • Safety Door Switches • Emergency Stop Devices
- Safety Switches & Operator Controls • Safety Monitoring/Force-guided Relays

Control Components

- Power Supplies • Timers • Counters • Programmable Relays
- Digital Panel Meters • Monitoring Products

Switches & Relays

- Limit Switches • Pushbutton Switches • Electromechanical Relays
- Solid State Relays

Software

- Programming & Configuration • Runtime