

### POWER MANAGEMENT

#### Description

The EZ1587 series of high performance positive voltage regulators are designed for use in applications requiring low dropout performance at up to 3A. Additionally, the EZ1587 series provides excellent regulation over variations in line, load and temperature.

Outstanding features include low dropout performance at rated current, fast transient response, internal current limiting and thermal shutdown protection of the output device.

A variety of options are available for maximum flexibility: the EZ1587C is intended for commercial applications and has both fixed and adjustable voltage options; the EZ1587I is intended for industrial applications and is adjustable only.

All devices are available in the popular TO-220 and TO-263 packages.

#### Features

- ◆ Low dropout voltage: 1.3V max. for EZ1587C and 1.4V max. for EZ1587I
- ◆ Full current rating over line and temperature
- ◆ Fast transient response
- ◆  $\pm 2\%$  total output regulation over line, load and temperature
- ◆ Adjust pin current max 90 $\mu$ A over temperature
- ◆ Fixed/adjustable output voltage (EZ1587C)
- ◆ Line regulation typically 0.015%
- ◆ Load regulation typically 0.05%
- ◆ Industrial temperature range (EZ1587I)
- ◆ TO-220 and TO-263 packages. Available in RoHS compliant package

#### Applications

- ◆ Printer and plotter supplies
- ◆ Instrumentation
- ◆ Medical equipment
- ◆ Microcontroller systems
- ◆ Telecommunication systems
- ◆ Motherboards
- ◆ Switching supply post regulation

#### Typical Application Circuit

##### Fixed Voltage Regulator

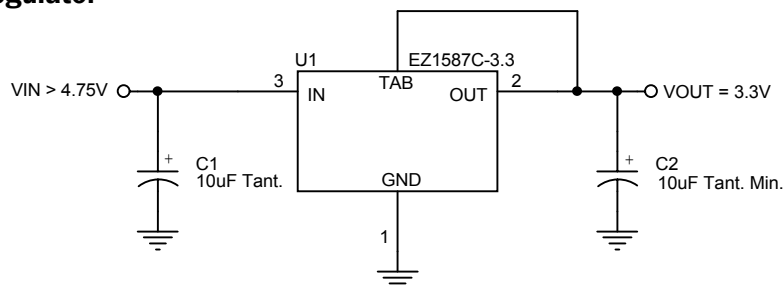

##### Adjustable Voltage Regulator

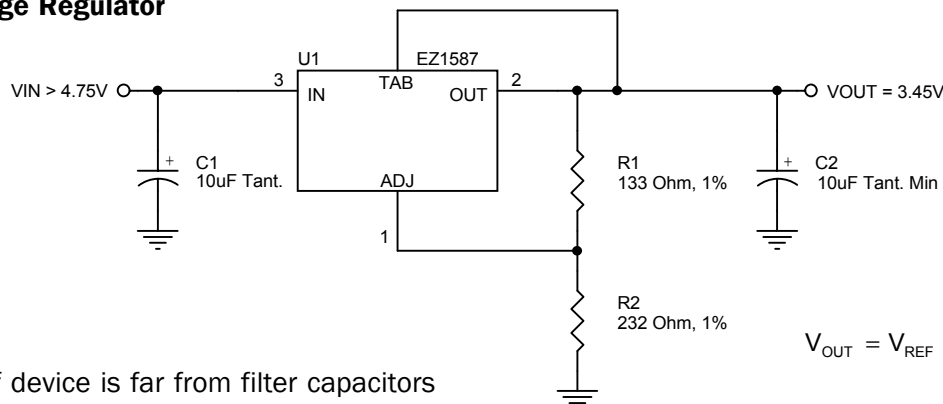

#### Notes:

- (1) C1 needed if device is far from filter capacitors
- (2) C2 minimum value required for stability

$$V_{OUT} = V_{REF} \cdot \left(1 + \frac{R2}{R1}\right) + I_{ADJ} \cdot R2$$

## POWER MANAGEMENT

### Absolute Maximum Ratings

Exceeding the specifications below may result in permanent damage to the device, or device malfunction. Operation outside of the parameters specified in the Electrical Characteristics section is not implied.

Parameter	Symbol	Maximum	Units
Input Supply Voltage	$V_{IN}$	7	V
Power Dissipation	$P_D$	Internally Limited	W
Thermal Resistance Junction to Case TO-220 TO-263	$\theta_{JC}$	3 3	$^{\circ}C/W$
Thermal Resistance Junction to Ambient TO-220 TO-263	$\theta_{JA}$	50 60	$^{\circ}C/W$
Operating Ambient Temperature Range EZ1587C EZ1587I	$T_A$	0 to 70 -40 to 85	$^{\circ}C$
Operating Junction Temperature Range EZ1587C EZ1587I	$T_J$	0 to 125 -40 to 125	$^{\circ}C$
Storage Temperature Range	$T_{STG}$	-65 to 150	$^{\circ}C$
Lead Temperature (Soldering) 10 Sec.	$T_{LEAD}$	300	$^{\circ}C$
ESD Rating (Human Body Model)	ESD	2	kV

### Electrical Characteristics

Unless otherwise specified: Adj.  $V_{IN} = 2.75V$  to  $7.0V$  and Adj.  $I_O = 10mA$  to  $3A$ ; Fixed  $V_{IN} = 4.75$  to  $7.0V$  and Fixed  $I_O = 0$  mA to  $3A$ .

Values in **bold** apply over full operating ambient temperature range.

Parameter	Symbol	$V_{IN}$	$I_O$	Min	Typ	Max	Units
Output Voltage <sup>(1)</sup> EZ1587C-X.X	$V_O$	5V	0mA	$0.985V_O$ <b><math>0.98V_O</math></b>	$V_O$	$1.015V_O$ <b><math>1.02V_O</math></b>	V
Reference Voltage <sup>(1)</sup> EZ1587C, EZ1587I	$V_{REF}$	5V	10mA	1.231 <b>1.225</b>	1.250	1.269 <b>1.275</b>	V
Line Regulation <sup>(1)</sup>	$REG_{(LINE)}$		10mA		0.015	<b>0.2</b>	%
Load Regulation <sup>(1)</sup>	$REG_{(LOAD)}$	5V			0.05	<b>0.4</b>	%
Dropout Voltage <sup>(1)(2)</sup> EZ1587C, EZ1587C-X.X EZ1587I	$V_D$		3.0A		1.20 1.20	<b>1.35</b> <b>1.40</b>	V
Current Limit	$I_{CL}$			<b>3.1</b>	4.5		A

## POWER MANAGEMENT

### Electrical Characteristics (Cont)

Unless otherwise specified: Adj.  $V_{IN}$  = 2.75V to 7.0V and Adj.  $I_O$  = 10mA to 3A; Fixed  $V_{IN}$  = 4.75 to 7.0V and Fixed  $I_O$  = 0 mA to 3A.  
 Values in **bold** apply over full operating ambient temperature range.

Parameter	Symbol	$V_{IN}$	$I_O$	Min	Typ	Max	Units
Quiescent Current Fixed Voltage Version	$I_Q$	5V			10	<b>13</b>	mA
Temperature Coefficient	$T_C$				0.005		%/°C
Adjust Pin Current	$I_{ADJ}$				55	<b>90</b>	μA
Adjust Pin Current Change	$\Delta I_{ADJ}$				0.2	<b>5</b>	μA
Temperature Stability	$T_S$	5V	0.5A		<b>0.5</b>		%
Minimum Load Current Adj Voltage Versions	$I_O$	5V			5	<b>10</b>	mA
RMS Output Noise <sup>(3)</sup>	$V_N$				0.003		% $V_O$
Ripple Rejection Ratio <sup>(4)</sup>	$R_A$	5V	3A	<b>60</b>	72		dB

#### NOTES:

- (1) Low duty cycle pulse testing with Kelvin connections required.
- (2)  $\Delta V_{OUT}, \Delta V_{REF} = 1\%$
- (3) Bandwidth of 10 Hz to 10 kHz.
- (4) 120 Hz input ripple ( $C_{ADJ}$  for ADJ = 25μF).

## POWER MANAGEMENT

### Pin Configurations

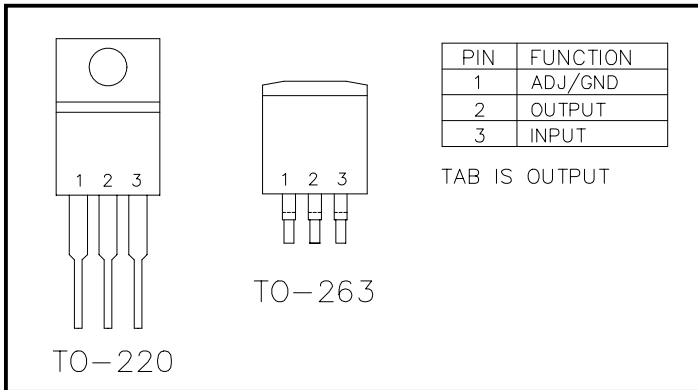

### Ordering Information

Device <sup>(1)(2)</sup>	Package
EZ1587CM-X.X.TR EZ1587IM.TR EZ1587CM-X.X.TRT <sup>(5)</sup> EZ1587IM.TRT <sup>(5)</sup>	TO-263 <sup>(3)</sup>
EZ1587CT-X.X EZ1587IT EZ1587CT-X.XT <sup>(5)</sup> EZ1587ITT <sup>(5)</sup>	TO-220 <sup>(4)</sup>

#### Notes:

- (1) Where X.X denotes voltage options (EZ1587C only). Available voltages are: 1.5V, 1.8V, 2.5V, and 3.3V. Leave blank for adjustable version (1.3 to 5.7V). Contact factory for additional voltage options.
- (2) Where C and I denote Commercial (0°C to 70°C) and Industrial (-40°C to 85°C) ambient temperature ranges.
- (3) Only available in tape and reel packaging. A reel contains 800 devices.
- (4) Only available in tube packaging. A tube contains 50 devices.
- (5) This product is RoHS compliant.

### Pin Descriptions

Pin	Pin Name	Pin Function
1	ADJUST	This pin is the negative side of the reference voltage for adjustable devices. Transient response can be improved by adding a small bypass capacitor from the adjust pin to ground.
	GROUND	This pin is the bottom end of the internal resistor feedback chain for fixed output voltage parts, and should be connected to ground.
2	OUTPUT	This is the power output of the device and is electrically connected to the TAB.
3	INPUT	This is the input supply pin for both the control circuitry and the pass device.

### Block Diagram

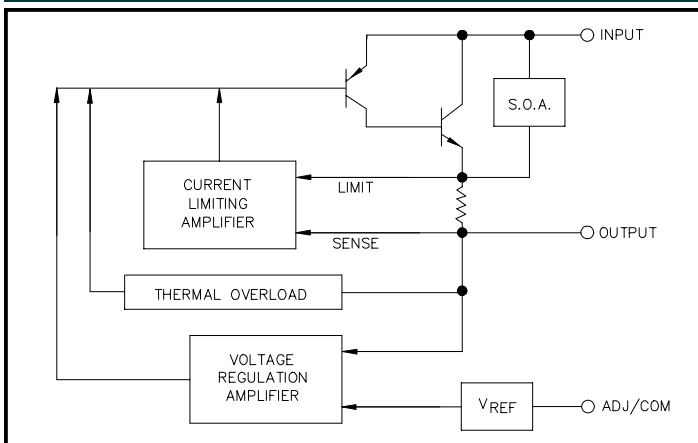

## POWER MANAGEMENT

### Outline Drawing - TO-220

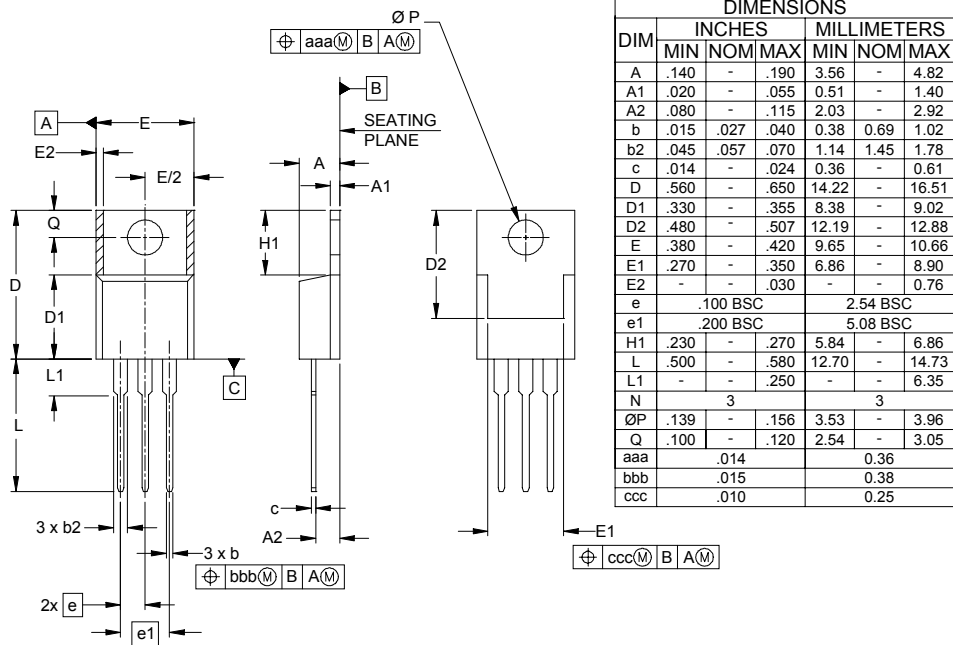

- NOTES:
1. CONTROLLING DIMENSIONS ARE IN INCHES.
  2. DIMENSIONS "D" AND "E" DO NOT INCLUDE MOLD FLASH, PROTRUSIONS OR GATE BURRS.

### Outline Drawing - TO-263

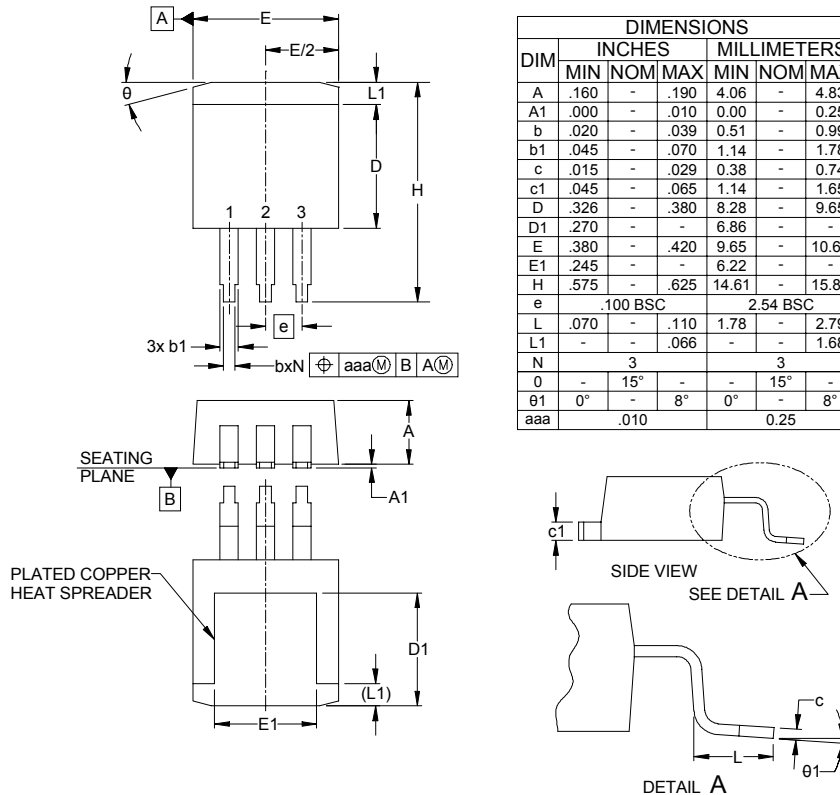

- NOTES:
1. CONTROLLING DIMENSIONS ARE IN INCHES (ANGLES IN DEGREES).
  2. DIMENSIONS "D" AND "E" DO NOT INCLUDE MOLD FLASH, PROTRUSIONS OR GATE BURRS.

POWER MANAGEMENT

Land Pattern - T0-263

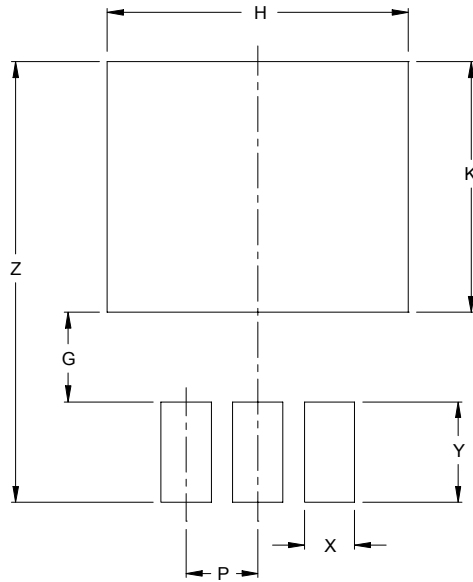

DIMENSIONS		
DIM	INCHES	MILLIMETERS
G	.125	3.17
H	.420	10.67
K	.350	8.89
P	.100	2.54
X	.070	1.78
Y	.140	3.56
Z	.615	15.62

NOTES:

1. THIS LAND PATTERN IS FOR REFERENCE PURPOSES ONLY  
CONSULT YOUR MANUFACTURING GROUP TO ENSURE YOUR  
COMPANY'S MANUFACTURING GUIDELINES ARE MET.

Contact Information

Semtech Corporation  
 Power Management Products Division  
 200 Flynn Road, Camarillo, CA 93012  
 Phone: (805)498-2111 FAX (805)498-3804