

Data Sheet

Description

These dual beam lead diodes are constructed using a metal-semiconductor Schottky barrier junction. Advanced epitaxial techniques and precise process control insure uniformity and repeatability of this planar passivated microwave semiconductor. A nitride passivation layer provides immunity from contaminants which could otherwise lead to IR drift.

The Avago beam lead process allows for large beam anchor pads for rugged construction (typical 6 gram pull strength) without degrading capacitance.

Applications

The beam lead diode is ideally suited for use in stripline or microstrip or coplanar waveguide circuits. Its small physical size and uniform dimensions give it low parasitics and repeatable RF characteristics through K-band.

These dual beam leads are intended for use in balanced mixers and in even harmonic anti-parallel pair mixers. By using several of these devices in the proper configuration it is easy to assemble bridge quads, star quads, and ring quads for Class I, II, or III type double balanced mixers.

Assembly Techniques

Thermocompression bonding is recommended. Welding or conductive epoxy may also be used. For additional information see Application Note 979, "The Handling and Bonding of Beam Lead Devices Made Easy," or Application Note 993, "Beam Lead Device Bonding to Soft Substrates."

Features

- Monolithic Pair: Closely Matched Electrical Parameters
- Low Capacitance: 0.1 pF Maximum at 0 Volts
- Low Noise Figure: Typical 7.5 dB at 26 GHz
- Rugged Construction: 4 Grams Minimum Lead Pull
- Platinum Tri-Metal System: High Temperature Stability
- Polyimide Scratch Protection
- Silicon Nitride Passivation: Stable, Reliable Performance

Outline 04B

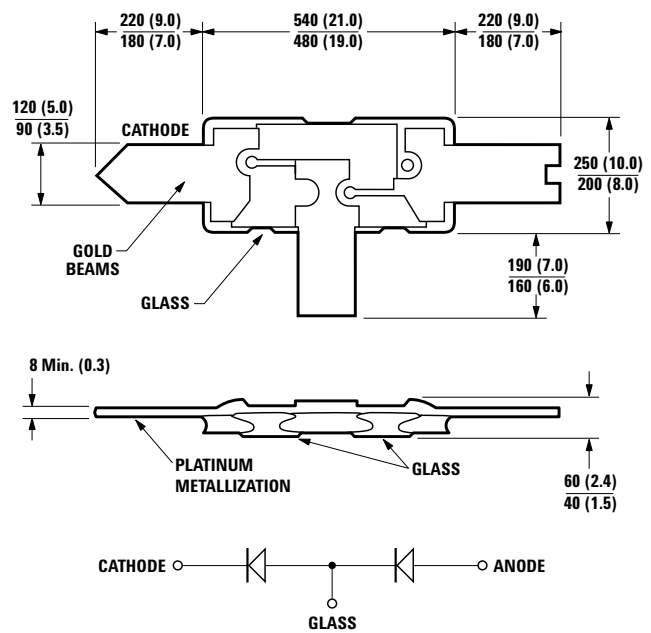

DIMENSIONS IN mm (1/1000 inch)

Maximum Ratings (for Each Diode)

Pulse Power Incident at $T_A = 25^\circ\text{C}$	1 W
Pulse Width = 1 μs , $D_u = 0.001$	
CW Power Dissipation at $T_A = 25^\circ\text{C}$	150 mW
<i>Measured in an infinite heat sink derated linearly to zero at maximum rated temperature</i>	
T_{OPR} – Operating Temperature Range	-65°C to $+175^\circ\text{C}$
T_{STG} – Storage Temperature Range	-65°C to $+200^\circ\text{C}$
Minimum Lead Strength.....	4 grams pull on any lead
Diode Mounting Temperature.....	350°C for 10 sec. max.

These diodes are ESD sensitive. Handle with care to avoid static discharge through the diode.

Electrical Specifications for DC Tested Diodes at $T_A = 25^\circ\text{C}$

Part Number HSCH-[1]	Barrier	Minimum Breakdown Voltage V_{BR} (V)	Maximum Dynamic Resistance R_{D} (Ω)	Max. ΔR_{D} (Ω)	Maximum Total Capacitance C_{T} (pF)	Max. ΔC_{T} (pF)	Maximum Forward Voltage V_{F} (mV)	Max. ΔV_{F} (mV)	Max. I_{R} (nA)
5512	Medium	4	16	3	0.15	0.03	500	10	100
5531	Low		20	3	0.10	0.02	375		400
Test Conditions		$I_{\text{R}} = 10 \mu\text{A}$	$I_{\text{F}} = 5 \text{ mA}$		$V_{\text{R}} = 0 \text{ V}$, $f = 1 \text{ MHz}$		$I_{\text{F}} = 1 \text{ mA}$		$V_{\text{R}} = 1$

Note:

1. Standard Hi-Rel program available on HSCH-5531. Others are available upon request.

Typical Detector Characteristics at $T_A = 25^\circ\text{C}$ **Medium Barrier and Low Barrier (DC Bias)**

Parameter	Symbol	Typical Value	Units	Test Conditions
Tangential Sensitivity	TSS	-55	dBm	$20 \mu\text{A}$ Bias, Zero Bias, $P_{\text{in}} = -40 \text{ dBm}$,
Voltage Sensitivity	γ	9.0	mV/ μW	$R_{\text{L}} = 100 \text{ K}\Omega$, Video Bandwidth = 2 MHz
Video Resistance	R_{V}	1350	Ω	$f = 10 \text{ GHz}$

Low Barrier (Zero Bias)

Parameter	Symbol	Typical Value	Units	Test Conditions
Tangential Sensitivity	TSS	-46	dBm	Zero Bias, Zero Bias, $P_{\text{in}} = -30 \text{ dBm}$,
Voltage Sensitivity	γ	17	mV/ μW	$R_{\text{L}} = 10 \text{ M}\Omega$, Video Bandwidth = 2 MHz
Video Resistance	R_{V}	1.4	$\text{M}\Omega$	$f = 10 \text{ GHz}$

SPICE Parameters

Parameter	Units	HSCH-5512	HSCH-5531
B_V	V	5	5
C_{J0}	pF	0.13	0.09
E_G	eV	0.69	0.69
I_{BV}	A	10E-5	10E-5
I_S	A	3 x 10E-10	4 x 10E-8
N		1.08	1.08
R_S	Ω	9	13
P_B	V	0.65	0.5
P_T		2	2
M	0.5	0.5	

Typical Parameters

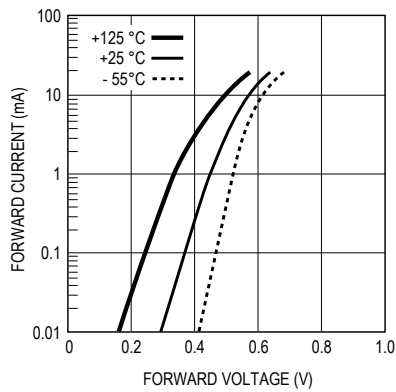

Figure 1. Typical forward characteristics for medium barrier beam lead diodes. HSCH-5512.

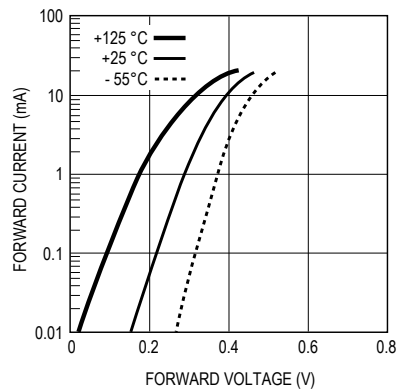

Figure 2. Typical forward characteristics for low barrier beam lead diodes. HSCH-5531.

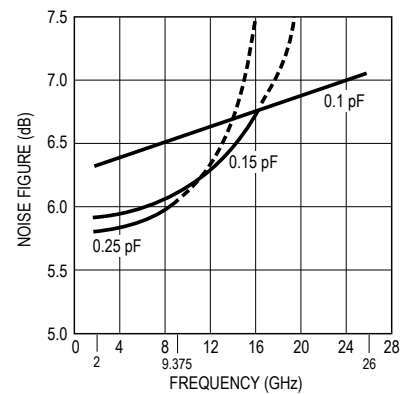

Figure 3. Typical noise figure vs. frequency.

Typical Parameters, continued

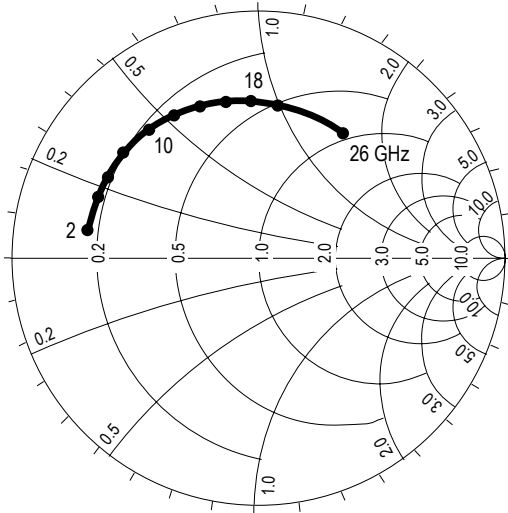

Figure 4. Typical Admittance Characteristics with 1 mA

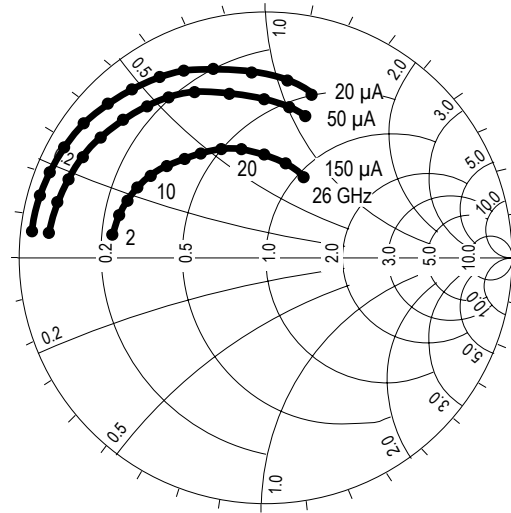

Figure 5. Typical Admittance Characteristics with

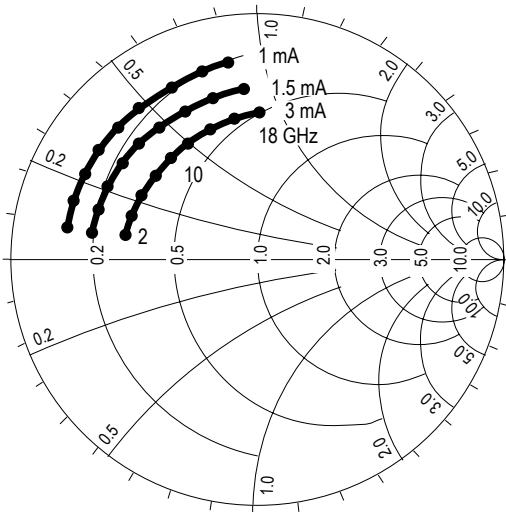

Figure 6. Typical Admittance Characteristics with Self Bias. HSCH-5512.

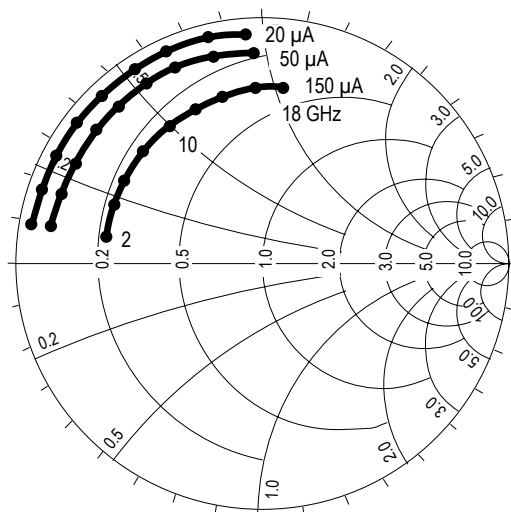
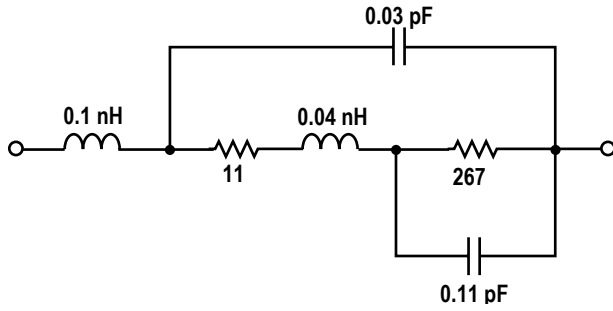

Figure 7. Typical Admittance Characteristics with External Bias.

Models for Each Beam Lead Schottky Diode

HSCH -5531

1 mA Self Bias



HSCH-5512

Self Bias

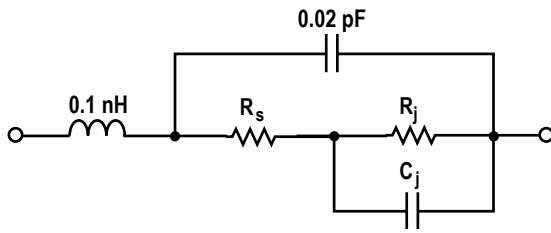

Part Number	1.0 mA Self Bias			1.5 mA Self Bias			3.0 mA Self Bias		
	R_1 (Ω)	R_2 (Ω)	C (pF)	R_1 (Ω)	R_2 (Ω)	C (pF)	R_1 (Ω)	R_2 (Ω)	C (pF)
HSCH-5512	5.0	393	0.11	5.2	232	0.11	5.0	150	0.12

Models for Each Beam Lead Schottky Diode, continued

HSCH -5531

External Bias

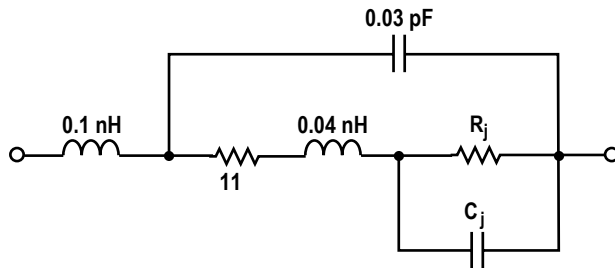

Part Numbers	20 μ A DC Bias		50 μ A DC Bias		150 μ A DC Bias	
	R_j (Ω)	C_j (pF)	R_j (Ω)	C_j (pF)	R_j (Ω)	C_j (pF)
HSCH-5531	1400	0.09	560	0.09	187	0.10

HSCH-5512

External Bias

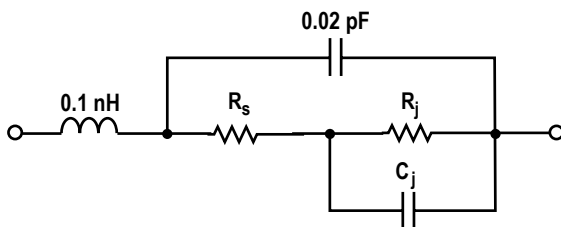

Part Numbers	20 μ A DC Bias			50 μ A DC Bias			150 μ A DC Bias		
	R_s (Ω)	R_j (Ω)	C_j (pF)	R_s (Ω)	R_j (Ω)	C_j (pF)	R_s (Ω)	R_j (Ω)	C_j (pF)
HSCH-5512	2.8	1240	0.11	4.7	550	0.12	2.7	180	0.13

For product information and a complete list of distributors, please go to our web site: www.avagotech.com

Avago, Avago Technologies, and the A logo are trademarks of Avago Technologies, Limited in the United States and other countries. Data subject to change. Copyright © 2006 Avago Technologies, Limited. All rights reserved. Obsoletes 5965-8850EN AV01-0595EN - October 19, 2006

AVAGO
TECHNOLOGIES