

26M SERIES

SMALL BUT POWERFUL

**GENERAL SPECIFICATIONS**

Step Angle	7.5° / 15°
Step Accuracy	± 0.5° / ± 1°
Operating Temperature	100°C Max
Ambient Temperature Range	-20°C ~ +70°C
Insulation Resistance at 500Vdc	100MΩ
Dielectric Withstanding Voltage	650 ± 50 VRMS, 2 sec

 [CLICK HERE TO PRINT THIS SERIES](#)
OPENS PDF IN NEW WINDOW

The specifications in this publication are believed to be accurate and reliable. However, it is the responsibility of the product user to determine the suitability of Portescap products for a specific application. While defective products will be replaced without charge if promptly returned, no liability is assumed beyond such replacement.

Portescap Danaher Motion motors will not be CE marked where the Low Voltage Directive, the Electro-Magnetic Compatibility or other appropriate EU directives are not applicable - this is an EU legal requirement.

TECHNICAL SPECIFICATIONS

	UNIPOLAR			
Part Number	26M024B1U	26M024B2U	26M048B1U	26M048B2U
DC Operating Voltage	5	12	5	12
Resistance per Winding (ohms)	19.6	110	19.6	110
Inductance per Winding (mH)	4.1	29.9	5.3	36.5
Holding Torque* (mNm/oz-in)	6.3 / 0.9	6.3 / 0.9	9.2/ 1.3	9.2/ 1.3
Rotor Moment of Inertia (g.m ²)	1.1 x 10 ⁻⁴	1.1 x 10 ⁻⁴	1.1 x 10 ⁻⁴	1.1 x 10 ⁻⁴
Detent Torque (mNm/oz-in)	1.34 / 0.19	1.34 / 0.19	1.34 / 0.19	1.34 / 0.19
Step Angle	15°	15°	7.5°	7.5°
Step Angle Tolerance*	± 1°	± 1°	± 0.5°	± 0.5°
Steps per Revolution*	24	24	48	48
Max. Operating Temperature	100°C	100°C	100°C	100°C
Ambient Temperature Range				
Operating	-20°C to 70°C	-20°C to 70°C	-20°C to 70°C	-20°C to 70°C
Storage	-40°C to 85°C	-40°C to 85°C	-40°C to 85°C	-40°C to 85°C
Bearing Type	Sintered bronze sleeve	Sintered bronze sleeve	Sintered bronze sleeve	Sintered bronze sleeve
Insulation Resistance at 500Vdc	100 megohms	100 megohms	100 megohms	100 megohms
Dielectric Withstanding Voltage	650 ± 50 VRMS, 2 sec	650 ± 50 VRMS, 2 sec	650 ± 50 VRMS, 2 sec	650 ± 50 VRMS, 2 sec
Weight (g/oz)	34 / 1.2	34 / 1.2	34 / 1.2	34 / 1.2
Leadwires	28 AWG, UL Style 1429	28 AWG, UL Style 1429	28 AWG, UL Style 1429	28 AWG, UL Style 1429

* Measured with 2 phases energized

TECHNICAL SPECIFICATIONS

	BIPOLAR			
Part Number	26M024B1B	26M024B2B	26M048B1B	26M048B2B
DC Operating Voltage	5	12	5	12
Resistance per Winding (ohms)	19.8	108	19.8	108
Inductance per Winding (mH)	7.7	52.4	13	60.7
Holding Torque* (mNm/oz-in)	7.8 / 1.1	7.8 / 1.1	10.6 / 1.5	10.6 / 1.5
Rotor Moment of Inertia (g.m ²)	1.1 x 10 ⁻⁴	1.1 x 10 ⁻⁴	1.1 x 10 ⁻⁴	1.1 x 10 ⁻⁴
Detent Torque (mNm/oz-in)	1.34 / 0.19	1.34 / 0.19	1.34 / 0.19	1.34 / 0.19
Step Angle	15°	15°	7.5°	7.5°
Step Angle Tolerance*	± 1°	± 1°	± 0.5°	± 0.5°
Steps per Revolution*	24	24	48	48
Max. Operating Temperature	100°C	100°C	100°C	100°C
Ambient Temperature Range				
Operating	-20°C to 70°C	-20°C to 70°C	-20°C to 70°C	-20°C to 70°C
Storage	-40°C to 85°C	-40°C to 85°C	-40°C to 85°C	-40°C to 85°C
Bearing Type	Sintered bronze sleeve	Sintered bronze sleeve	Sintered bronze sleeve	Sintered bronze sleeve
Insulation Resistance at 500Vdc	100 megohms	100 megohms	100 megohms	100 megohms
Dielectric Withstanding Voltage	650 ± 50 VRMS, 2 sec	650 ± 50 VRMS, 2 sec	650 ± 50 VRMS, 2 sec	650 ± 50 VRMS, 2 sec
Weight (g/oz)	34 / 1.2	34 / 1.2	34 / 1.2	34 / 1.2
Leadwires	28 AWG, UL Style 1429	28 AWG, UL Style 1429	28 AWG, UL Style 1429	28 AWG, UL Style 1429

* Measured with 2 phases energized

MECHANICAL DIMENSIONS

UNITS = MM / INCHES

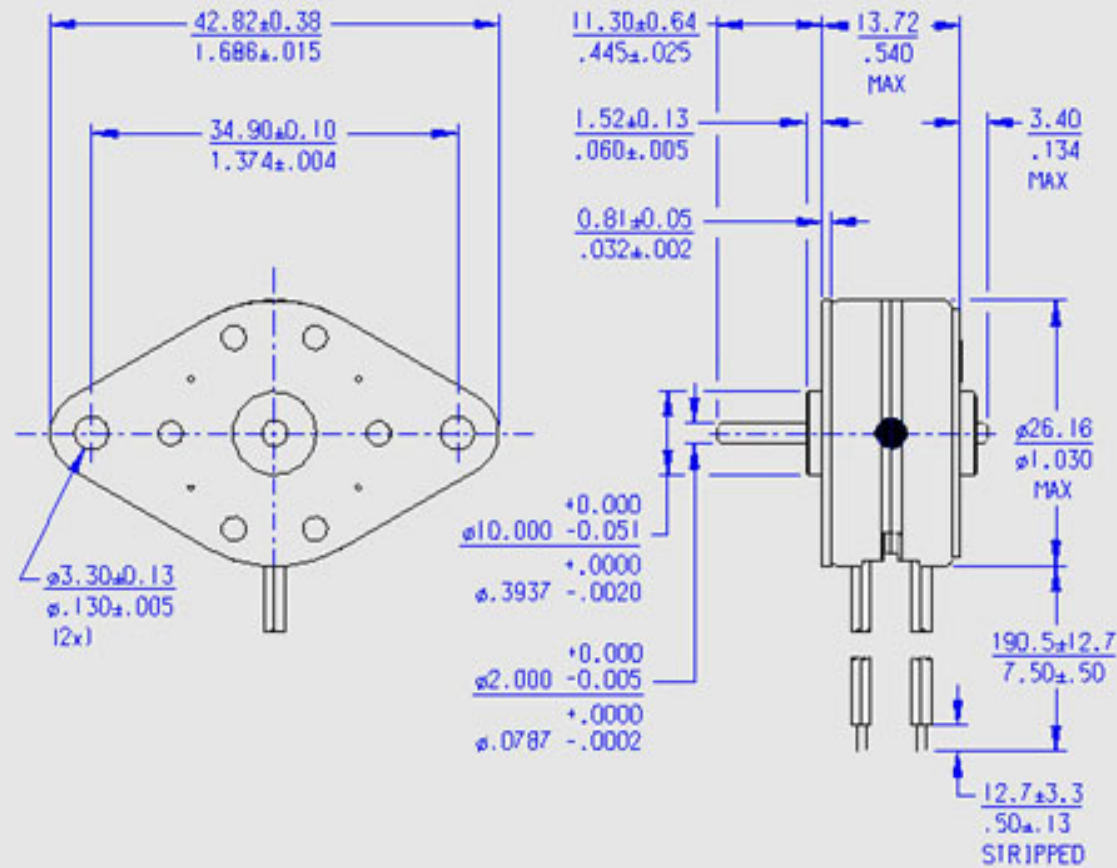

WIRING DIAGRAM

CLICK ON A THUMBNAIL TO MAGNIFY

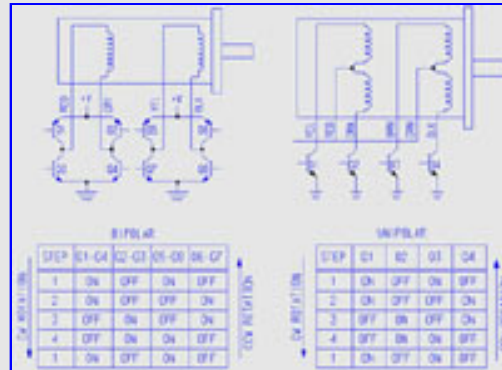

26M024B SERIES

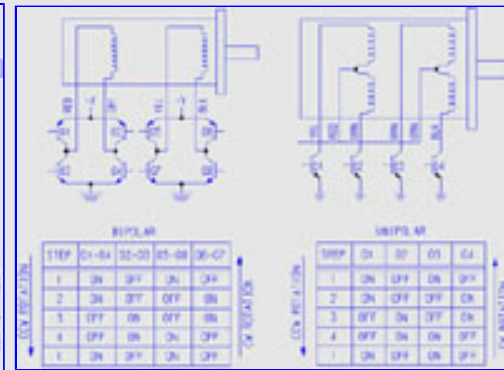

26M048B SERIES

MOTOR DYNAMICS

CLICK ON A THUMBNAIL TO MAGNIFY

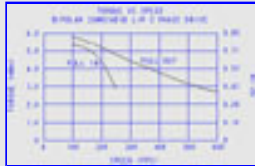

26M024B1B, Bipolar, L/R Drive

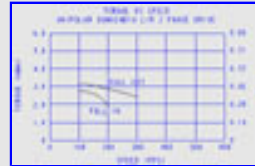

26M024B1U, Unipolar, L/R Drive

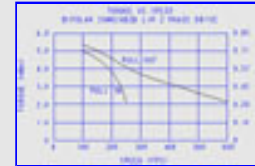

26M024B2B, Bipolar, L/R Drive

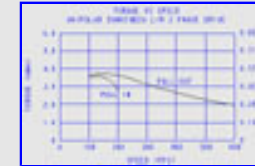

26M024B2U, Unipolar, L/R Drive

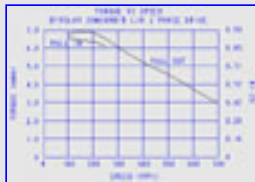

26M048B1B, Bipolar, L/R Drive

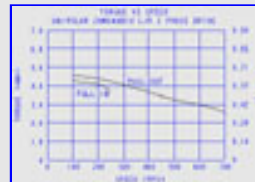

26M048B1U, Unipolar, L/R Drive

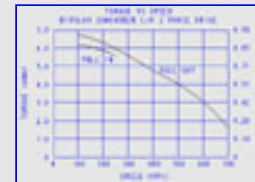

26M048B2B, Bipolar, L/R Drive



26M048B2U, Unipolar, L/R Drive



26M024B1B, Bipolar, Chopper Drive



26M048B1B, Bipolar, Chopper Drive

WIRING DIAGRAM

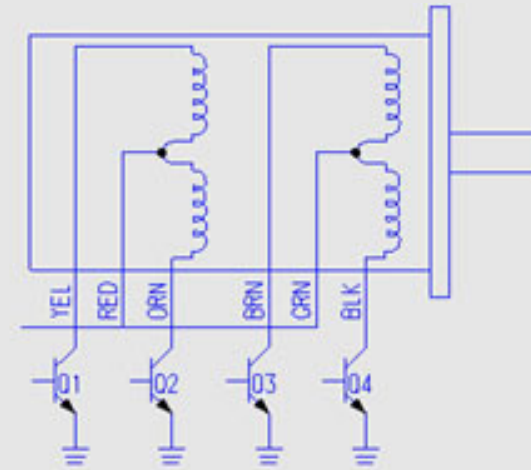
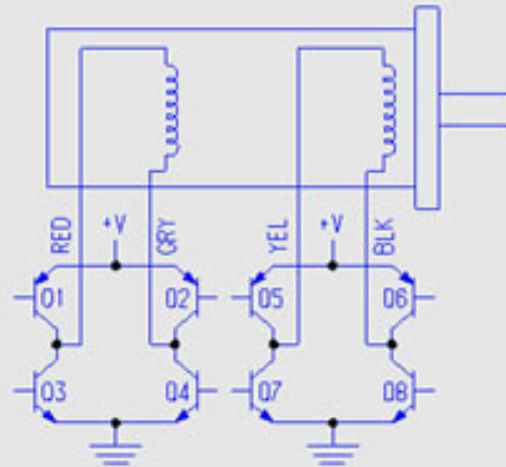

BIPOLAR

STEP	01-04	02-03	05-08	06-07
1	ON	OFF	ON	OFF
2	ON	OFF	OFF	ON
3	OFF	ON	OFF	ON
4	OFF	ON	ON	OFF
1	ON	OFF	ON	OFF

CW ROTATION (downward arrow) and CCW ROTATION (upward arrow) are indicated on the sides of the table.

UNIPOLAR

STEP	01	02	03	04
1	ON	OFF	ON	OFF
2	ON	OFF	OFF	ON
3	OFF	ON	OFF	ON
4	OFF	ON	ON	OFF
1	ON	OFF	ON	OFF

CW ROTATION (downward arrow) and CCW ROTATION (upward arrow) are indicated on the sides of the table.

26M024B SERIES

WIRING DIAGRAM



DIAGRAM INDEX

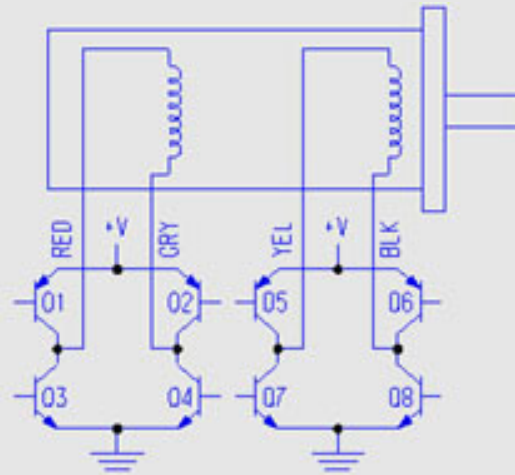

BIPOLAR

STEP	01-04	02-03	05-08	06-07
1	ON	OFF	ON	OFF
2	ON	OFF	OFF	ON
3	OFF	ON	OFF	ON
4	OFF	ON	ON	OFF
1	ON	OFF	ON	OFF

CCW ROTATION (downward arrow) and CW ROTATION (upward arrow) are indicated on the left and right sides of the table.

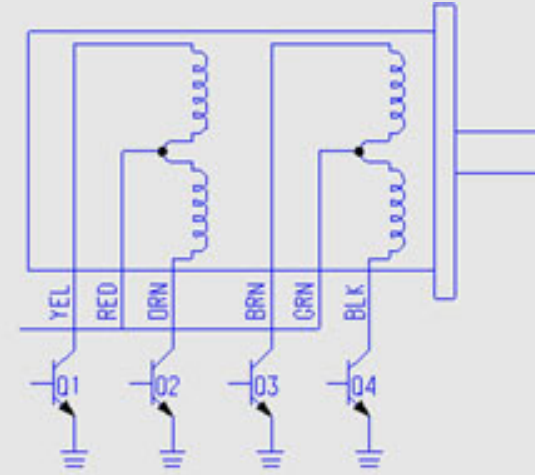

UNIPOLAR

STEP	01	02	03	04
1	ON	OFF	ON	OFF
2	ON	OFF	OFF	ON
3	OFF	ON	OFF	ON
4	OFF	ON	ON	OFF
1	ON	OFF	ON	OFF

CCW ROTATION (downward arrow) and CW ROTATION (upward arrow) are indicated on the left and right sides of the table.

26M048B SERIES

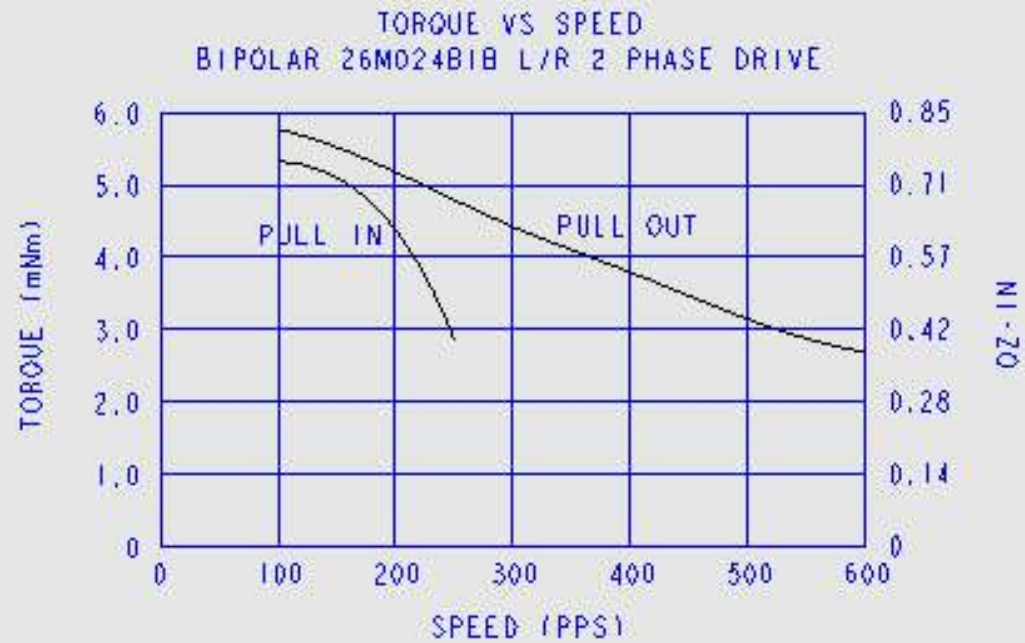

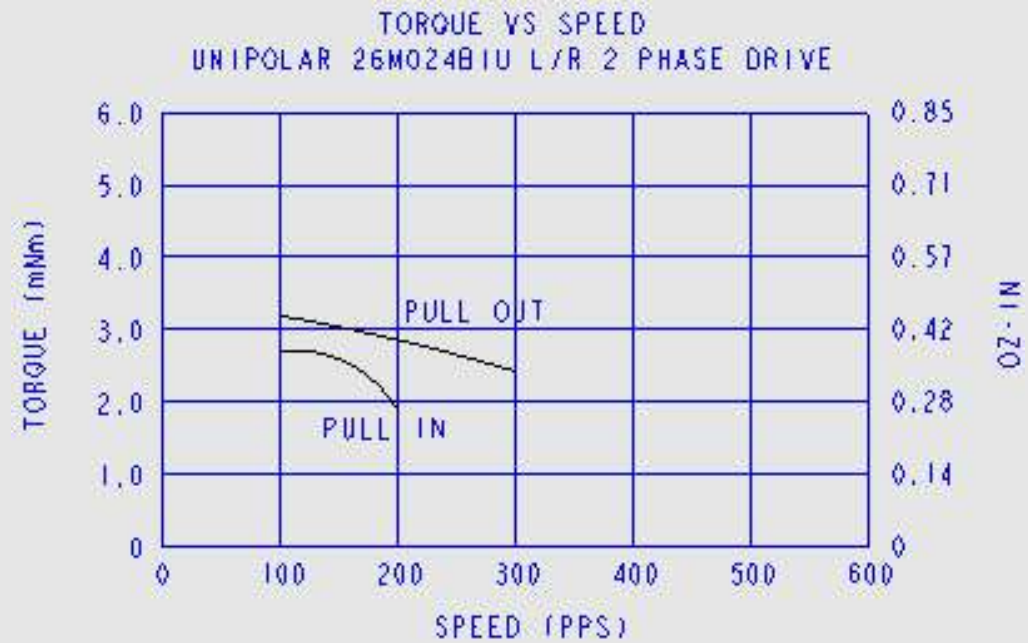

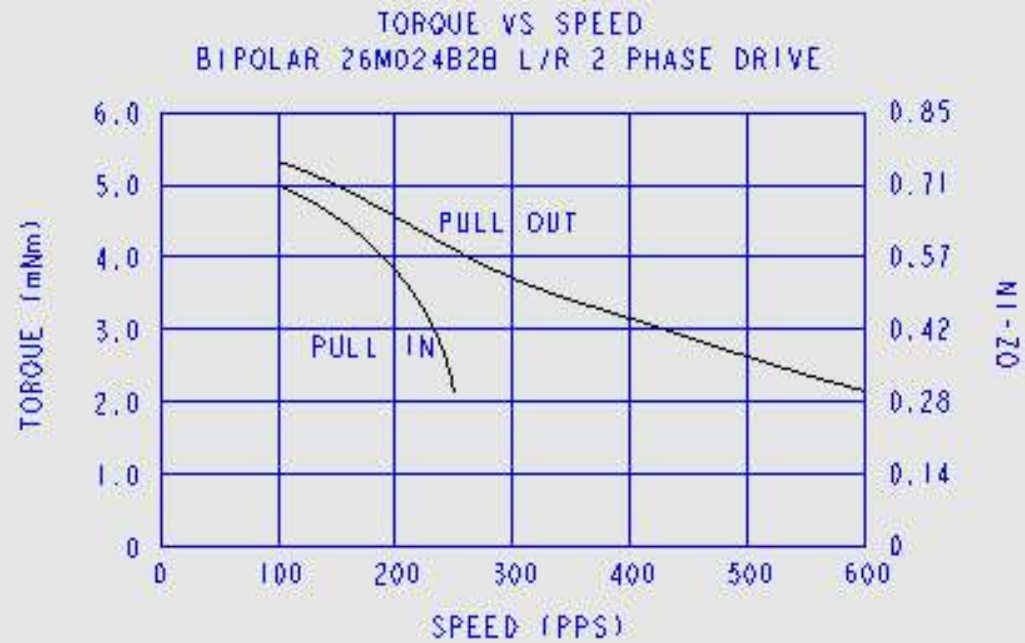

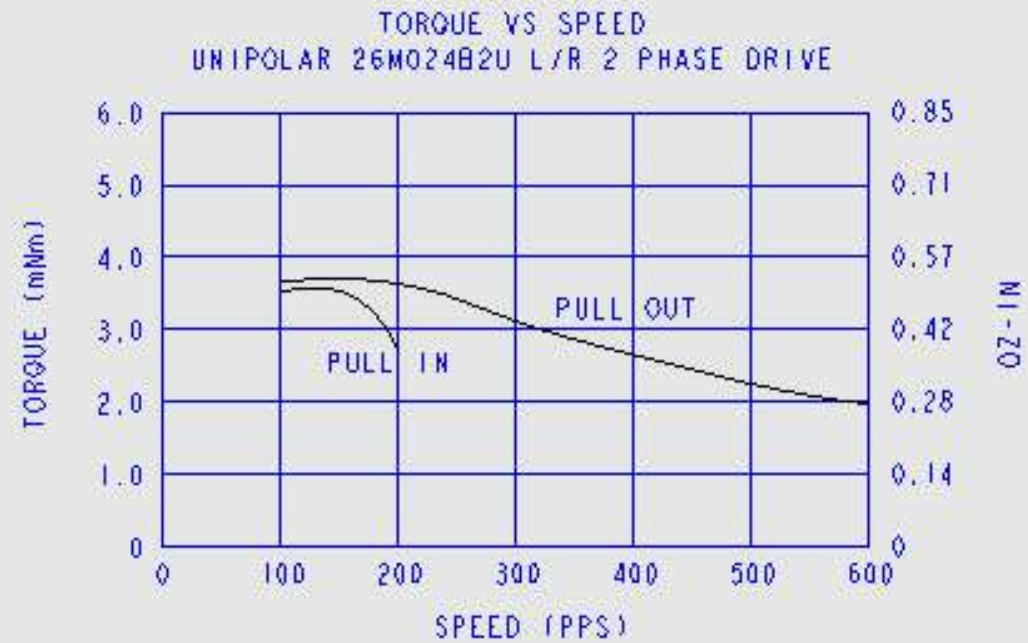

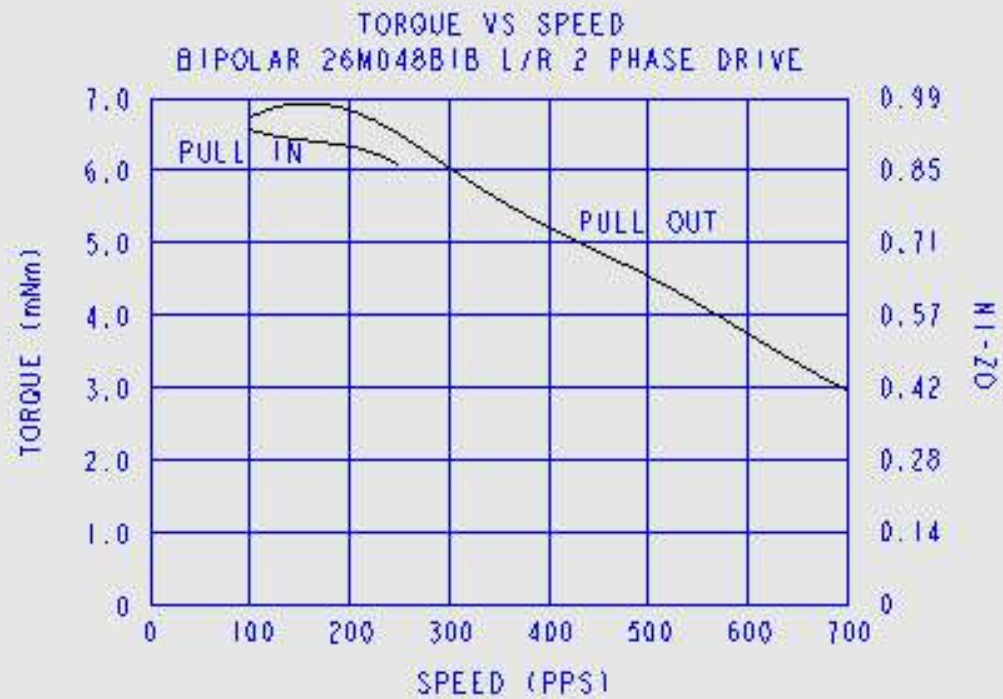

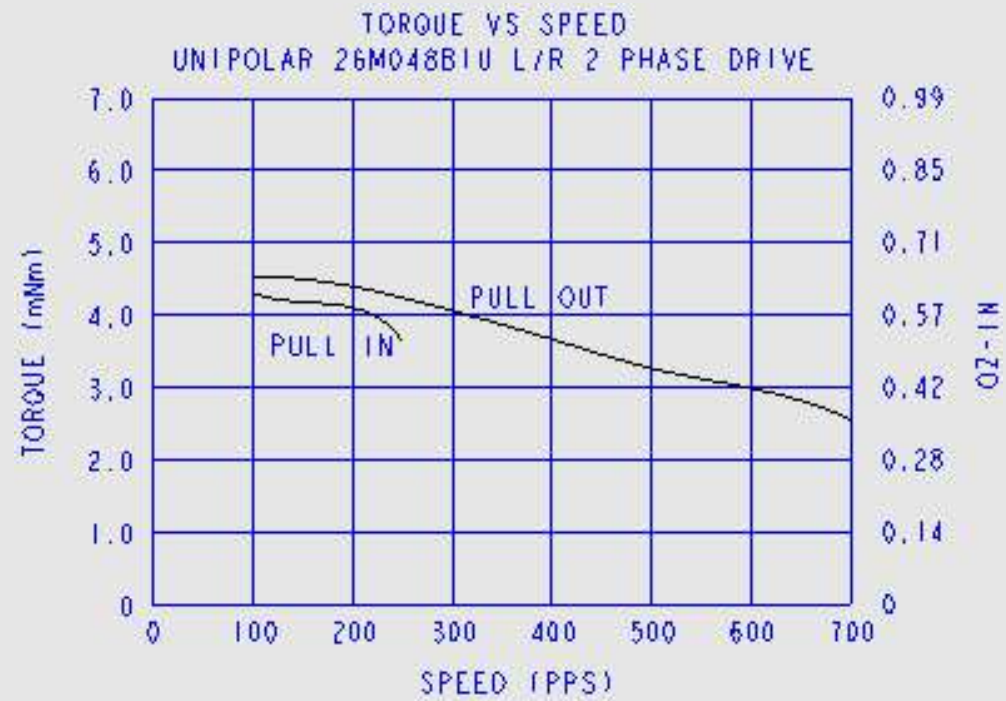

MOTOR DYNAMICS



CHART INDEX

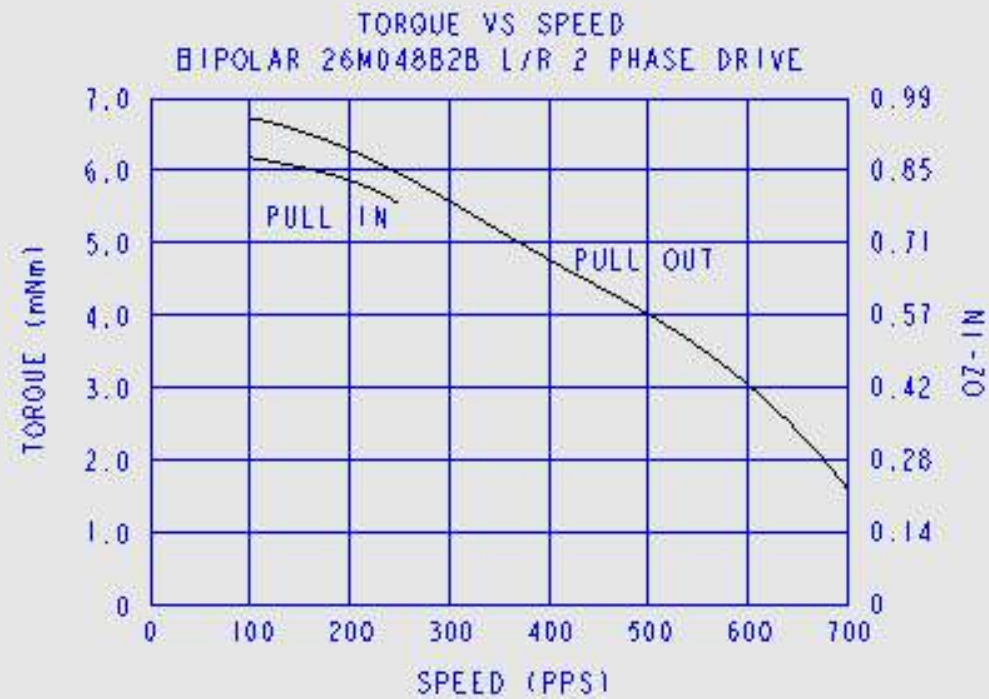

MOTOR DYNAMICS



CHART INDEX

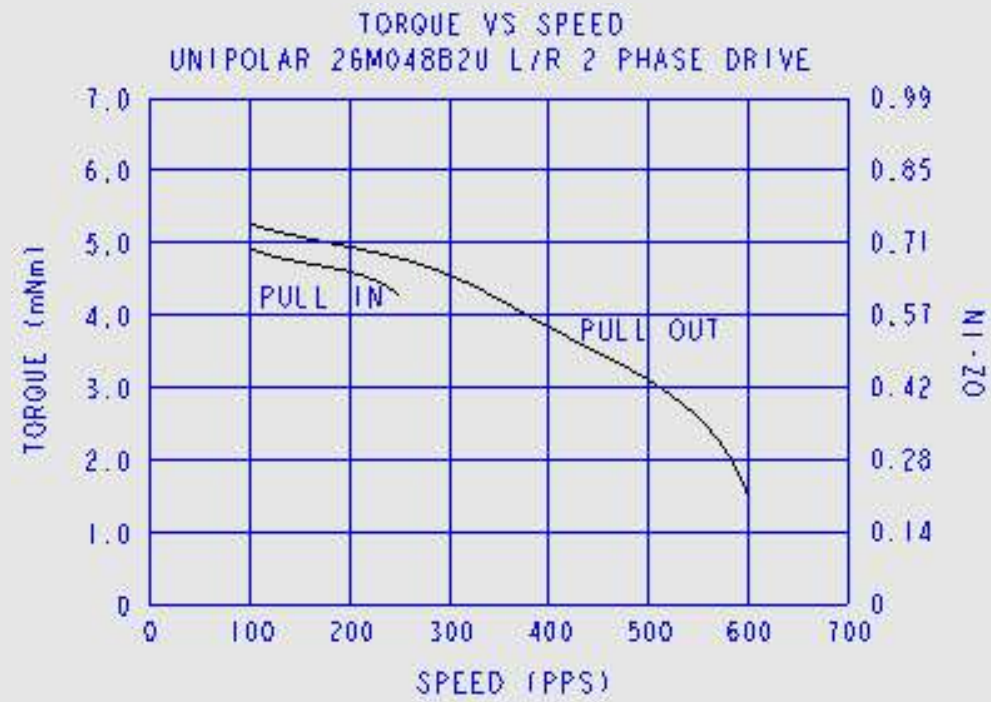



TORQUE VS SPEED

BIPOLAR 26M024B1B CHOPPER DRIVE
@ 36V, 250mA/Ø, 2Ø

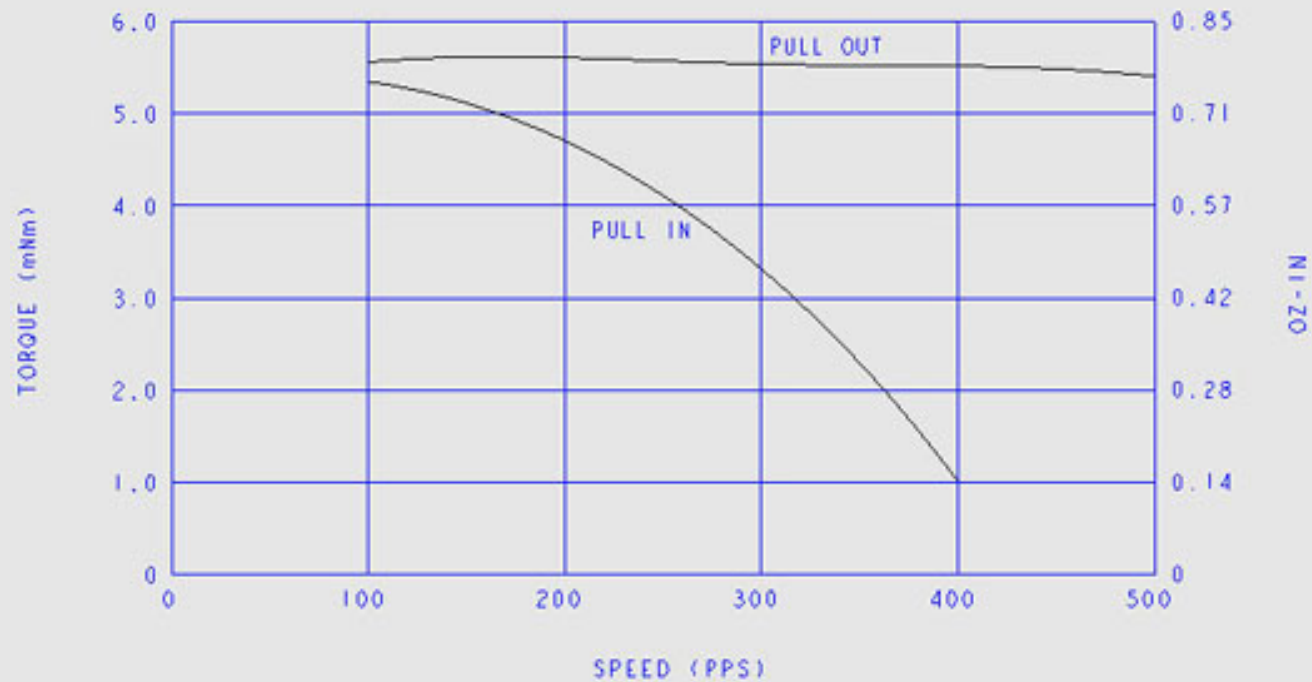



TORQUE VS SPEED

BIPOLAR 26M048BIB CHOPPER DRIVE
@ 36V, 250mA/Ø, 2Ø

