

Datasheet

Low-cost TEACH-mode sensors for use with plastic fiber optics



- Low-cost, 10 V dc to 30 V dc, self-contained sensors for use with all Banner plastic fiber optics
- Compact 11 mm-wide housing designed for DIN rail mounting; also mounts to other surfaces using the supplied mounting bracket
- Easy push-button TEACH-mode programming automatically adjusts sensitivity to optimal setting
- D11E sensors are designed for low-contrast sensing applications (sensitivity set to just above the dark condition)
- D11E2 series sensors set the switching point midway between the dark and light conditions to ignore subtle changes, such as web flutter
- Fast, 200 microsecond (0.2 millisecond) output response; a 40 millisecond output pulse stretcher also may be programmed
- Models available with NPN (sinking) or PNP (sourcing) output
- Output may be programmed for either light operate (LO) or dark operate (DO)
- Separate input allows remote programming by an external device, such as a switch or a process controller
- LED status indications for power ON, output state, received signal strength, and sensing contrast



WARNING: Not To Be Used for Personnel Protection

Never use this device as a sensing device for personnel **protection**. Doing so could lead to serious injury or death. This device does not include the self-checking redundant circuitry necessary to allow its use in personnel safety applications. A sensor failure or malfunction can cause either an energized or de-energized sensor output condition.

Models	Switching Threshold Setting	Cable ¹	Output Type	Maximum Range (Diffuse mode performance based on 90% reflectance white test card)
D11EN6FP	Just above the dark condition	2 m (6.5 ft)	NPN (sinking)	Range varies by sensing mode and fiber optics used: <ul style="list-style-type: none"> • PIT46U fibers, opposed mode: 180 mm (7.1 in)² • PIT26U fibers, opposed mode: 50 mm (2.0 in) • PBT46U fiber, diffuse mode: 50 mm (2.0 in) • PBT26U fiber, diffuse mode: 10 mm (0.4 in)
D11EN6FPQ		4-pin Pico QD		
D11EP6FP		2 m (6.5 ft)	PNP (sourcing)	
D11EP6FPQ		4-pin Pico QD		
D11EP6FP W/30		9 m (30 ft)		
D11E2N6FP	Midway between dark and light conditions	2 m (6.5 ft)	NPN (sinking)	
D11E2N6FPQ		4-pin Pico QD	PNP (sourcing)	
D11E2P6FP		2 m (6.5 ft)		
D11E2P6FPQ		4-pin Pico QD		

Installation

Mount the D11 on a DIN rail or the included bracket.

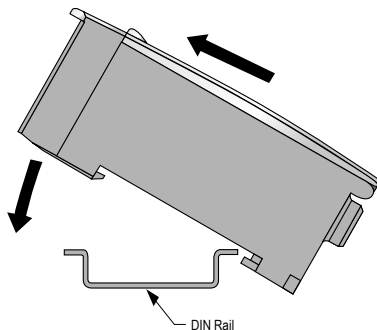

¹ Models with a quick disconnect require a mating cordset.

² Opposed-mode range may be extended using optional lenses (see www.bannerengineering.com for available lenses).



Installing Plastic Fibers

1. Cut the fiber ends according to the instructions included with the fibers.
2. Slide the fiber gripper up (open).
3. If you are using 0.254 mm or 0.508 mm (0.010 inch or 0.020 inch) diameter fibers: Insert the adaptor into the ports as far as it will go.

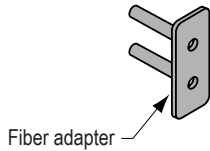

4. For all fiber diameters: Insert the prepared plastic fiber sensor ends gently into the ports as far as they will go.
5. Slide the fiber gripper back down to lock it.

Wiring Diagrams

Sensors with NPN (Sinking) Outputs	Sensors with PNP (Sourcing) Outputs
------------------------------------	-------------------------------------

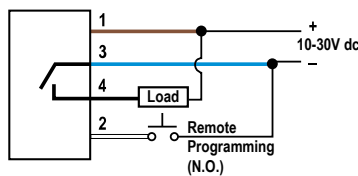

Figure 1. Cabled Hookup

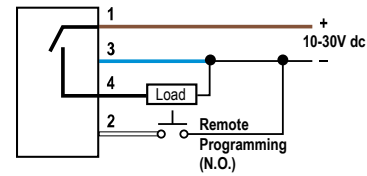

Figure 2. Cabled Hookup

Quick disconnect (QD) wiring diagrams are functionally identical.

Run Mode

Run mode is the normal operation of the D11 Expert series. The LED indicators operate in Run mode, as follows:

		Indicator	LED Color	Function
	1	Signal Strength (SIG)	Red	Lights when the sensor sees its modulated light source and pulses at a rate proportional to the received light signal strength.
	2	Output	Amber	Follows the action of the output: <ul style="list-style-type: none"> • On when the output is energized • Off when the output is de-energized
	3	Power ON	Green	Solid when power is applied. Flashes at approximately 4 Hz to indicate the output is overloaded
	4	Button	n/a	Programming push button

The Signal Strength indicator is Banner's exclusive AID™ (Alignment Indicating Device[®]). This feature simplifies accurate alignment during TEACH mode and provides a means of signaling when maintenance is needed during Run mode. When the pulse rate is slow, clean the fiber sensing ends and check the alignment.

Maximum Sensitivity/Factory Defaults

The sensors are factory-programmed for maximum sensitivity. This default setting may be easily recalled by holding the push button for two or more seconds to enter TEACH mode, and then clicking the push button four times in a row.

The default program also is set for light operate output and pulse stretcher OFF, push button enabled.

[®] U.S. Patent #4356393

Perform the procedures in this document to program your own settings.

TEACH Mode

Sensitivity is automatically set (and optimized) by teaching the sensor the light and dark conditions. This is accomplished in TEACH mode. TEACH mode requires that each of the two sensing conditions be presented to the fiber optics; when the push button is clicked, the sensor samples the sensing condition and registers it into memory. After the second sensing condition is registered, the D11 Expert automatically sets the sensitivity to the optimum value for the application, and then returns to Run mode.



Note: There is a period of a few seconds at the end of TEACH mode, before Run mode begins.

Light or Dark Operate Selection

The two sensing conditions may be presented in either order: the light condition first, and then the dark condition, or vice versa. The condition presented first is the condition for which the output energizes. In other words, the output will be light operated if the light condition is TEACH condition #1, or the output will be dark operated if the dark condition is TEACH condition #1.

D11E sensors automatically set to a point just above the dark condition for the best performance in low contrast sensing applications; D11E2 sensors automatically set to a point midway between the dark and light conditions, to ignore subtle changes, such as web flutter.

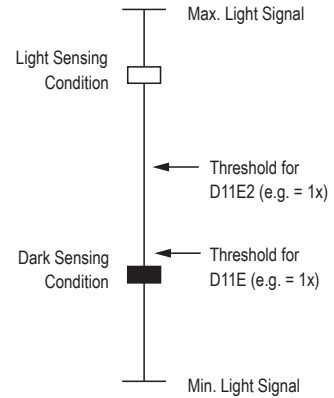

Contrast Indication

When the push button is clicked to teach the second sensing condition, the three LED indicators flash simultaneously to indicate relative sensing contrast. Contrast is the difference in light level between the two sensing conditions.

Higher contrast allows higher sensitivity level, and resulting higher excess gain. A high contrast level is directly related to sensing reliability, and is more forgiving of subtle changes in sensing conditions. The contrast display at the end of TEACH mode is shown, at right.

Table 1: Contrast Indication

Number of flashes at end of TEACH mode	Relative Contrast
1	Unacceptable
2	Low
3	Moderate
4	High



Note: If the relative contrast level is unacceptable (1 flash), the program returns to TEACH condition #1.

TEACH Mode Programming

- | Action | Result |
|--|---|
| Press and hold the button for more than 2 seconds. | Green LED: Flashes at 1 Hz
Amber LED: Off
Red LED: Pulses to indicate relative received signal strength |
- TEACH Condition #1 (output ON state).

Action	Result
a. Present the first sensing condition to the sensor. b. Single-click the button. ⁴ This condition corresponds to the sensor output ON state.	Green: Flashes at 2 Hz Amber: OFF Red: Pulses to indicate relative received signal strength
- TEACH Condition #2 (output OFF state).

⁴ The sensor returns to RUN mode if the first TEACH condition is not registered within 20 seconds. TEACH mode may be cancelled before either condition #1 or #2 by pressing the push button for more than 2 seconds.

Action	Result
a. Present the second sensing condition to the sensor. b. Single-click the button. This condition corresponds to the sensor output OFF state.	Green, amber, and red indicators flash simultaneously one to four times to indicate relative sensing contrast (see Table 1 on page 3) . After a few seconds, the sensor returns to RUN mode.

Output Pulse Stretcher

A 40 millisecond pulse stretcher (OFF-delay) may be enabled for applications where a very short sensing event might be missed because of the response of the load or input connected to the sensor output. Turn the pulse stretcher ON or OFF using the following procedure.

1.	<table border="1"> <thead> <tr> <th>Action</th> <th>Result</th> </tr> </thead> <tbody> <tr> <td>Press and hold the button for more than 2 seconds.</td> <td> Green LED: Flashes at 1 Hz Amber LED: Off Red LED: Pulses to indicate relative received signal strength </td> </tr> </tbody> </table>	Action	Result	Press and hold the button for more than 2 seconds.	Green LED: Flashes at 1 Hz Amber LED: Off Red LED: Pulses to indicate relative received signal strength		
Action	Result						
Press and hold the button for more than 2 seconds.	Green LED: Flashes at 1 Hz Amber LED: Off Red LED: Pulses to indicate relative received signal strength						
2.	<table border="1"> <thead> <tr> <th>Action</th> <th>Result</th> </tr> </thead> <tbody> <tr> <td>a. Double-click the button to display status.</td> <td> Pulse Stretcher ON Green: Off Amber: Off Red: Solid on </td> </tr> <tr> <td>b. Single-click the button to toggle pulse stretcher ON or OFF.</td> <td> Pulse Stretcher OFF Green: Off Amber: Off Red: Double-flash </td> </tr> </tbody> </table>	Action	Result	a. Double-click the button to display status.	Pulse Stretcher ON Green: Off Amber: Off Red: Solid on	b. Single-click the button to toggle pulse stretcher ON or OFF.	Pulse Stretcher OFF Green: Off Amber: Off Red: Double-flash
Action	Result						
a. Double-click the button to display status.	Pulse Stretcher ON Green: Off Amber: Off Red: Solid on						
b. Single-click the button to toggle pulse stretcher ON or OFF.	Pulse Stretcher OFF Green: Off Amber: Off Red: Double-flash						
3.	<table border="1"> <thead> <tr> <th>Action</th> <th>Result</th> </tr> </thead> <tbody> <tr> <td>Double-click the button to save the configuration and return to Run mode.</td> <td>See Run Mode on page 2</td> </tr> </tbody> </table>	Action	Result	Double-click the button to save the configuration and return to Run mode.	See Run Mode on page 2		
Action	Result						
Double-click the button to save the configuration and return to Run mode.	See Run Mode on page 2						

Remote Programming

Connect the D11 Expert's white wire to a remote switch for three sensor programming functions:

1. Disable or enable the push button
2. TEACH mode programming of sensitivity
3. Enable or disable the 40-millisecond pulse stretcher.

Connect a remote programming switch between the white wire and dc common (see [Wiring Diagrams](#) on page 2). The switch may be either a normally open contact, or an open-collector NPN transistor with its emitter connected to dc common.

Program the sensor using a specified sequence of input pulses. The duration of each pulse is defined as: $0.04 \text{ seconds} < T < 0.8 \text{ seconds}$.

The required spacing between adjacent pulses in a sequence (for example, a double-pulse) is: $0.04 < T < 0.8 \text{ seconds}$. The timing diagrams illustrate the input requirements.

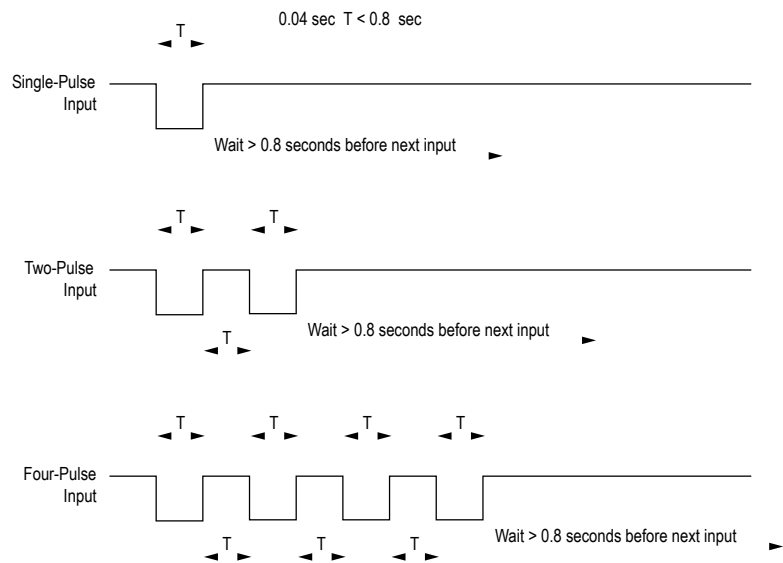

Figure 3. Timing Programs

Disable or Enable the Push Button

When remote programming is used exclusively, it may be beneficial to disable the push button on the D11E to increase the security of the settings.

1. To disable the push button: Pulse the remote input four times.
2. To enable the push button at a later date: Pulse the input four times (again).



Note: The push button can be enabled and/or disabled via remote line only.

Set Sensitivity Via TEACH Mode

1. Present the first (output ON) sensing condition to the sensor and pulse the remote input once.
2. Present the second (output OFF) sensing condition to the sensor and pulse the remote input once. The three LED indicators flash simultaneously one to four times to indicate relative sensing contrast. The sensor returns to RUN mode.

Enable or Disable the 40-millisecond Pulse Stretcher

1. Pulse the remote input two times. The status of the pulse stretcher is indicated by the red LED: ON if the pulse stretcher is ON, and double-flash if the pulse stretcher is OFF.
2. Pulse the remote input once to toggle the pulse stretcher ON or OFF.
3. Pulse the remote input two times to save the setting and return to Run mode.

Specifications

Supply Voltage and Current

10 V dc to 30 V dc (10% maximum ripple) at less than 45 mA, exclusive of load

Supply Protection Circuitry

Protected against reverse polarity and transient voltages

Output Configuration

One (SPST) NPN (sinking) or PNP (sourcing) open-collector transistor, depending on model; programmable for light or dark operate

Output Rating

150 mA maximum
 Off-state leakage current: < 5 microamps at 30 V dc
 On-state saturation voltage: < 1 V at 10 mA dc; <1.5 V at 150 mA dc

Output Protection Circuitry

Protected against false pulse on power-up and continuous overload or short-circuit

Output Response Time

200 microseconds (0.2 milliseconds) ON and OFF (40 milliseconds OFF when pulse stretcher is programmed).



Note: 100 millisecond delay on power-up; output is non-conducting during this time.

Output Timing Functions

ON/OFF (no delay) or fixed 40 millisecond OFF-delay pulse stretcher; selected by push button

Required Fiber Optic Cable

PI or PB Series plastic fibers

Sensing Beam

Visible red, 680 nm

Repeatability

66 microseconds

Adjustments

Push button TEACH mode sensitivity setting; remote TEACH mode input is provided

Indicators

Three LEDs: Green, Yellow, and Red
 Green LED lights for dc power ON and flashes when ready to register the sensing condition during TEACH mode: 1 Hz when waiting to learn first sensing condition; 2 Hz when waiting to learn second sensing condition; 4 Hz when output is overloaded.
 Yellow LED lights for output ON (conducting).
 Red LED is Banner's patented Alignment Indicating Device (AID™, U.S. patent #4356393) which lights whenever the sensor sees a light condition and superimposes a pulse rate which is proportional to the strength of the received light signal (the stronger the signal, the faster the pulse rate).

Construction

Black ABS flame retardant housing with acrylic cover
 Stainless steel M3 x 0.5 hardware for use with ABS mounting bracket (supplied)

Environmental Rating

IEC IP54; NEMA 2

Connections

2 m (6.5 ft) or 9 m (30 ft) attached cable, or 4-pin Pico-style quick-disconnect fitting; cables for QD models are purchased separately

Operating Conditions

Operating Temperature: -10 °C to +55 °C (+14 °F to +131 °F)
 90% at +50 °C maximum relative humidity (non-condensing)

Required Overcurrent Protection



WARNING: Electrical connections must be made by qualified personnel in accordance with local and national electrical codes and regulations.

Overcurrent protection is required to be provided by end product application per the supplied table.

Overcurrent protection may be provided with external fusing or via Current Limiting, Class 2 Power Supply.

Supply wiring leads < 24 AWG shall not be spliced.

For additional product support, go to www.bannerengineering.com.

Supply Wiring (AWG)	Required Overcurrent Protection (Amps)
20	5.0
22	3.0
24	2.0
26	1.0
28	0.8
30	0.5

Certifications



Dimensions

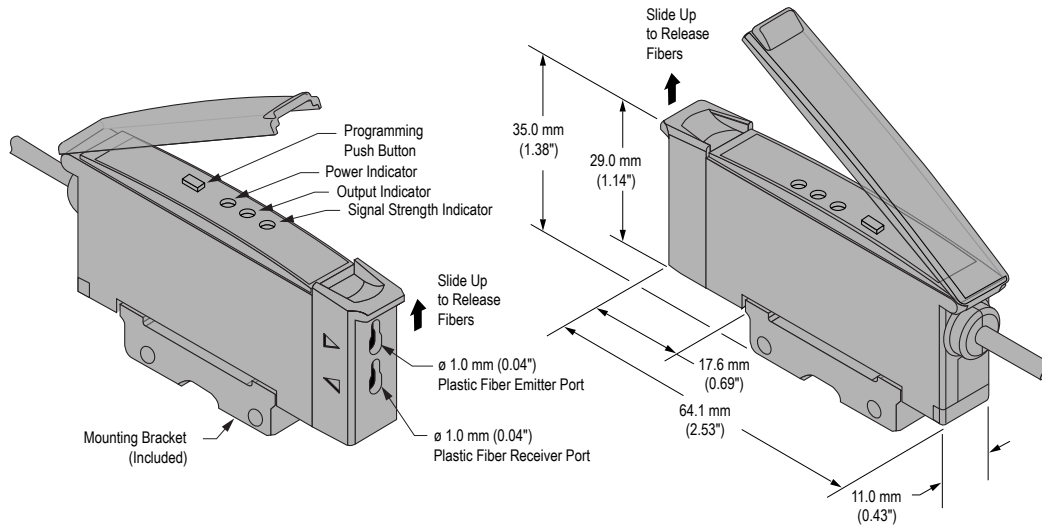

Figure 4. Cabled Models

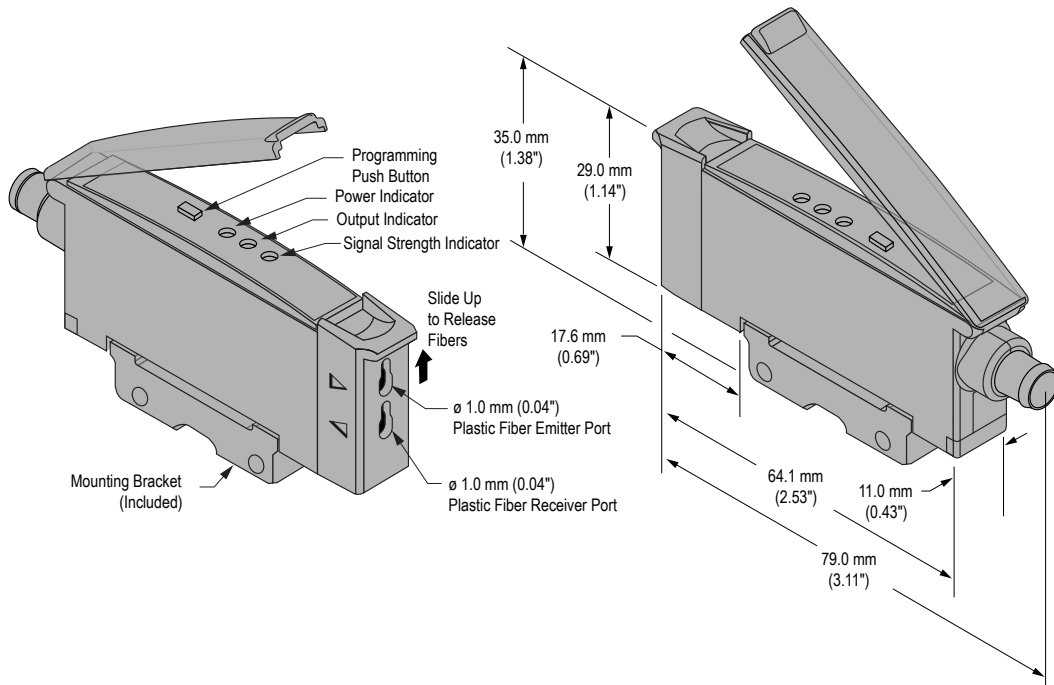

Figure 5. Quick Disconnect Models

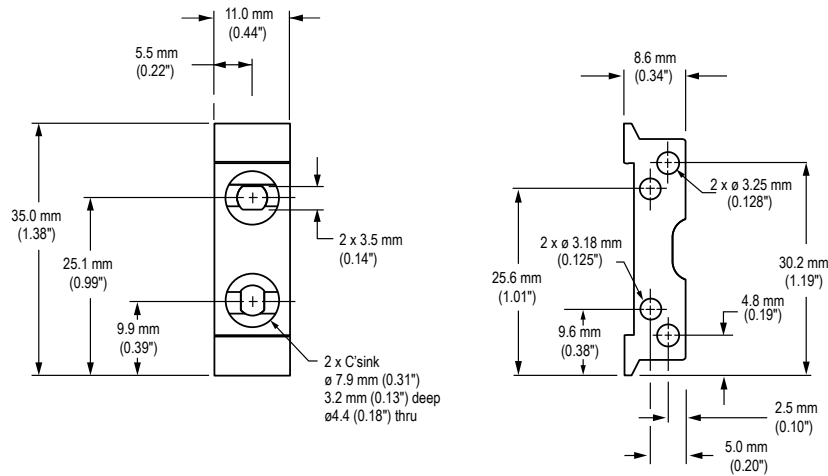

Figure 6. Mounting Bracket

Accessories

4-Pin Snap-on M8/ Pico-Style Cordsets				
Model	Length	Style	Dimensions	Pinout (Female)
PKG4-2	2 m (6.56 ft)	Straight		<p>1 = Brown 2 = White 3 = Blue 4 = Black</p>
PKW4Z-2	2 m (6.56 ft)	Right-Angle		

Banner Engineering Corp. Limited Warranty

Banner Engineering Corp. warrants its products to be free from defects in material and workmanship for one year following the date of shipment. Banner Engineering Corp. will repair or replace, free of charge, any product of its manufacture which, at the time it is returned to the factory, is found to have been defective during the warranty period. This warranty does not cover damage or liability for misuse, abuse, or the improper application or installation of the Banner product.

THIS LIMITED WARRANTY IS EXCLUSIVE AND IN LIEU OF ALL OTHER WARRANTIES WHETHER EXPRESS OR IMPLIED (INCLUDING, WITHOUT LIMITATION, ANY WARRANTY OF MERCHANTABILITY OR FITNESS FOR A PARTICULAR PURPOSE), AND WHETHER ARISING UNDER COURSE OF PERFORMANCE, COURSE OF DEALING OR TRADE USAGE.

This Warranty is exclusive and limited to repair or, at the discretion of Banner Engineering Corp., replacement. IN NO EVENT SHALL BANNER ENGINEERING CORP. BE LIABLE TO BUYER OR ANY OTHER PERSON OR ENTITY FOR ANY EXTRA COSTS, EXPENSES, LOSSES, LOSS OF PROFITS, OR ANY INCIDENTAL, CONSEQUENTIAL OR SPECIAL DAMAGES RESULTING FROM ANY PRODUCT DEFECT OR FROM THE USE OR INABILITY TO USE THE PRODUCT, WHETHER ARISING IN CONTRACT OR WARRANTY, STATUTE, TORT, STRICT LIABILITY, NEGLIGENCE, OR OTHERWISE.

Banner Engineering Corp. reserves the right to change, modify or improve the design of the product without assuming any obligations or liabilities relating to any product previously manufactured by Banner Engineering Corp. Any misuse, abuse, or improper application or installation of this product or use of the product for personal protection applications when the product is identified as not intended for such purposes will void the product warranty. Any modifications to this product without prior express approval by Banner Engineering Corp will void the product warranties. All specifications published in this document are subject to change; Banner reserves the right to modify product specifications or update documentation at any time. Specifications and product information in English supersede that which is provided in any other language. For the most recent version of any documentation, refer to: www.bannerengineering.com.