

L15

INCREMENTAL OPTICAL ENCODER

Introduction

The L15 provides the industrial marketplace with a rugged high resolution encoder in a compact size 15 servo package. Engineered with robust interpolative electronics, the L15 offers up to 40,640 cycles per turn. Ideal for space or weight limited applications, these compact encoders discount size without compromising performance. The L15 encoder features a 1/4-inch diameter stainless steel shaft and can accommodate up to 5 pounds radial or axial load. The L15 encoder package has field-proven ASIC electronics, sealed dual bearings and BEI's accurate code disk in an all metal housing to ensure ruggedness and reliability.



Features

- Robustness and excellent resistance to shocks / vibrations
- Protection level to IP53
- High Resolutions Available: Up to 40,640 ppr
- Universal Electronic Circuits from 5 to 28 Vdc +/- 10% Vdc
- Operating temperature range up to -40° to +85°C
- High bandwidth: Up to 1MHz

Applications

- Factory automation
- Motor feedback
- Conveyors
- Automated warehousing
- General industrial system monitoring and feedback

SPECIFICATIONS

Mechanical

Shaft Diameter	1/4 inch nominal
Shaft Loading	Up to 5 pounds axial and 5 pounds radial
Shaft Runout	0.002 T.I.R. at midpoint of shaft
Starting Torque at 25°C	0.20 in-oz (max)
Bearings	Sealed, instrument grade
Shaft Material	416 stainless steel
Bearing Housing	Aluminum with protective finish
Cover	Drawn aluminum
Bearing Life	1 X 10 ⁹ revs (10,000 hrs at 1500 RPM)
Maximum RPM	5,000 RPM nominal (see Frequency Response, below)
Moment of Inertia	1.0 X 10 ⁻⁴ oz-in-sec ²
Weight	6 oz (max)

Electrical

Output Format	2 channels in quadrature, 1/2 cycle index gated with negative B channel
Cycles Per Shaft Turn	See Resolutions list, below
Supply Voltage	5-28 VDC
Current Requirements	100mA typical + output load 250mA (max), 150mA (max) with 28V/5
Voltage/Output	28V/V: Line Driver, 5–28VDC _{in} , Vout = Vin 28V/5: Line Driver, 5–28VDC _{in} , Vout = 5 Vdc 28V/OC: Open Collector, Vout = OC, Vin = 5 - 28 Vdc
Protection Level	Reverse, overvoltage and output short circuit
Frequency Response	100kHz (non-interpolated), Up to 1 MHz interpolated
Output Termination Pinouts	See Output Functions, below

Environmental

Enclosure Rating	NEMA 3. (IP53)
Temperature	Operating, 0° to 70° C; extended temperature testing available, -40° to 85° ; storage, -40° to 90° C
Shock	50 G's for 11 msec duration (1/2 Sine)
Vibration	20 to 2000 Hz @ 20 g's
Humidity	98% RH non-condensing



OUTPUT FUNCTIONS

Color	Function
RED	+V (SUPPLY)
BLK	0 V (COMMON)
YEL	A
WHT/YEL	A/
BLU	B
WHT/BLU	B/
ORN	Z
WHT/ORN	Z/
BARE	SHIELD DRAIN



RESOLUTIONS (NON-INTERPOLATED)

24 50 100 200 256 300 360 400 500 512 625 900 1000 1024 1200 1250 1440 1800 2000 2048 2500 2540

Interpolation up to 16X is available.



OUTPUT WAVEFORMS

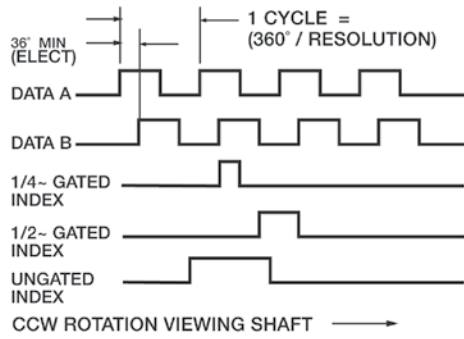

DIMENSIONS

All dimensions are in inches.

Tolerances: .XX=±0.02, .XXX=±0.005

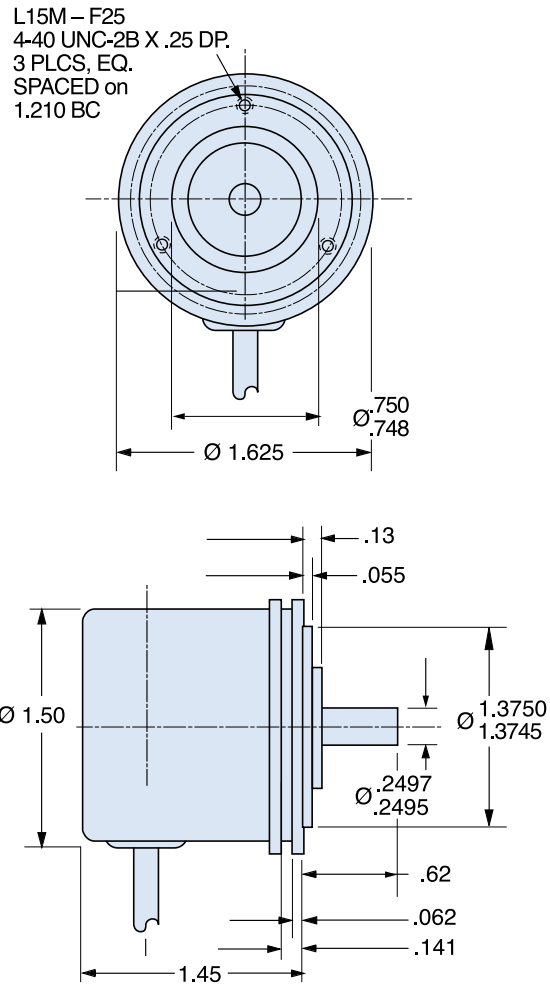



ORDERING OPTIONS

Example : L15M-F25-256- - ABZC - 28V/V - SCS18 -

	L15	M	F25	256		ABZC	28V/V	SCS18	
Type									
L = Light Duty 15 = 1.5 inch diameter									
Housing									
M = Standard									
Face Mount									
F25 = Standard									
Resolution (Number of Cycles)									
1 to 2540 See Resolutions section									
Interpolation									
T2, T3, T4, T5, T8,T10, T12, T16									
Channels									
ABZ ABZC See Output Functions									
Voltage/Output									
28V/V : Line Driver, 5–28VDCin, Vout = Vin 28V/5 : Line Driver, 5–28VDCin, Vout = 5 Vdc 28V/OC : Open Collector, Vout = OC, Vin = 5 - 28 Vdc See note 2									
Output Termination									
SCS = Shielded, Jacketed Cable with Cable Gland Seal and Cable length in inches (i.e. SCS18 = Pigtail 18 inches) See Output Functions									
Special Features									
S = Special features specified on purchase order (consult factory) See note 3									



AGENCY APPROVALS & CERTIFICATIONS

CE EN 55011 and EN 61000-6-2



GENERAL NOTES

- Complementary outputs are recommended for use with line driver type (source/sink) outputs. When used with differential receivers, this combination provides a high degree of noise immunity.
- Output IC's: Output IC's are available as either Line Driver (LD) or NPN Open Collector (OC) types. Open Collectors require pull-up resistors, resulting in higher output source impedance (sink impedance is similar to that of line drivers). In general, use of a Line Driver style output is recommended. Line Drivers source or sink current and their lower impedance mean better noise immunity and faster switching times. **Warning:** Do not connect any line driver outputs directly to circuit common/OV, which may damage the driver. Unused outputs should be isolated and left floating. Our applications specialists would be pleased to discuss your system requirements and the compatibility of your receiving electronics with Line Driver type outputs.
28V/V: Multi-voltage Line Driver (7272*): 100 mA source/sink. Input voltage 5 to 28 VDC +/- 5% standard (Note: Vout = Vin). This driver is TTL compatible when used with 5 volt supply. Supply lines are protected against overvoltage to 60 volts and reverse voltage. Outputs are short circuit protected for one minute. Supply current is 120 mA typical (plus load current). This is the recommended replacement for 3904R and 7406R open collector outputs with internal pullup resistors. It is also a direct replacement for any 4469, 88C30, 8830 or 26LS31 line driver.
28V/5: Multi-voltage Line Driver (7272*): 100 mA source/sink. Input voltage 5 to 28 VDC +/- 5% standard, internally regulated with 5V (TTL compatible) logic out. Supply lines are protected against overvoltage to 60 volts and reverse voltage. Outputs are short circuit protected for one minute. Supply current is 90 mA typical (plus load current). Note: Limit encoder load to 2.5W max at ambient. Example at 12 VDC: 2.5W/

(+12VDC minus +5VDC) = 357 mA total allowed current. Consult factory for your specific requirements.

15V/V: Multi-voltage Line Driver (4469*): 100 mA source/sink. Input voltage 5 to 15 VDC +/- 5% standard (Note: $V_{out} = V_{in}$). TTL compatible when used with 5 volt supply. Supply lines are protected against overvoltage to 60 volts and reverse voltage. Outputs are short circuit protected for one minute. Supply current is 90 mA typical (plus load current). This is a direct replacement for the 4469 Line Driver.

28V/OC: NPN Open Collector (3904*, 7273*). Current sink of 80 mA max. Current sourced by external pull-up resistor. Output can be pulled up to voltage other than supply voltage (30 V max). Input voltage 5 to 28 VDC +/- 5% standard. Supply current is 120 mA typical. This replaces prior IC's with designations of 3904, 7406, 3302, 681 and 689.

5V/OCR, 15V/OCR, 24V/OCR: Open Collector (3904R*, 7406R*, 7273R*): Current sink of 70 mA max. Includes internal pull-ups sized at approximately 100 ohms/volt. Max current source is 10 mA. Supply current is 100 mA typical, 120 mA with internal pull-ups. The 5V/ OCR, 15V/ OCR and 24V/OCR are often replaced by the 28V/V in system upgrades.

3. Special -S at the end of the model number is used to define a variety of non-standard features such as special shaft lengths, voltage options, or special testing. Please consult the factory to discuss your special requirements.
4. Higher frequency response may be available. Please consult with the factory.
5. Extended temperature ratings are available in the following ranges: -40 to 70°C, -40 to 85°C, -20 to 105°C and -40 to 105°C depending on the particular model. Some models can operate down to -55°C. Extended temperature ranges can affect other performance factors. Consult with factory for more specific information.

Sensata Technologies, Inc. ("Sensata") data sheets are solely intended to assist designers ("Buyers") who are developing systems that incorporate Sensata products (also referred to herein as "components"). Buyer understands and agrees that Buyer remains responsible for using its independent analysis, evaluation and judgment in designing Buyer's systems and products. Sensata data sheets have been created using standard laboratory conditions and engineering practices. Sensata has not conducted any testing other than that specifically described in the published documentation for a particular data sheet. Sensata may make corrections, enhancements, improvements and other changes to its data sheets or components without notice.

Buyers are authorized to use Sensata data sheets with the Sensata component(s) identified in each particular data sheet. HOWEVER, NO OTHER LICENSE, EXPRESS OR IMPLIED, BY ESTOPPEL OR OTHERWISE TO ANY OTHER SENSATA INTELLECTUAL PROPERTY RIGHT, AND NO LICENSE TO ANY THIRD PARTY TECHNOLOGY OR INTELLECTUAL PROPERTY RIGHT, IS GRANTED HEREIN. SENSATA DATA SHEETS ARE PROVIDED "AS IS". SENSATA MAKES NO WARRANTIES OR REPRESENTATIONS WITH REGARD TO THE DATA SHEETS OR USE OF THE DATA SHEETS, EXPRESS, IMPLIED OR STATUTORY, INCLUDING ACCURACY OR COMPLETENESS. SENSATA DISCLAIMS ANY WARRANTY OF TITLE AND ANY IMPLIED WARRANTIES OF MERCHANTABILITY, FITNESS FOR A PARTICULAR PURPOSE, QUIET ENJOYMENT, QUIET POSSESSION, AND NON-INFRINGEMENT OF ANY THIRD PARTY INTELLECTUAL PROPERTY RIGHTS WITH REGARD TO SENSATA DATA SHEETS OR USE THEREOF.

All products are sold subject to Sensata's terms and conditions of sale supplied at www.sensata.com SENSATA ASSUMES NO LIABILITY FOR APPLICATIONS ASSISTANCE OR THE DESIGN OF BUYERS' PRODUCTS. BUYER ACKNOWLEDGES AND AGREES THAT IT IS SOLELY RESPONSIBLE FOR COMPLIANCE WITH ALL LEGAL, REGULATORY AND SAFETY-RELATED REQUIREMENTS CONCERNING ITS PRODUCTS, AND ANY USE OF SENSATA COMPONENTS IN ITS APPLICATIONS, NOTWITHSTANDING ANY APPLICATIONS-RELATED INFORMATION OR SUPPORT THAT MAY BE PROVIDED BY SENSATA.

Mailing Address: Sensata Technologies, Inc., 529 Pleasant Street, Attleboro, MA 02703, USA.

CONTACT US

Americas

+1 (800) 350 2727

sensors@sensata.com

Europe, Middle East & Africa

+33 (3) 88 20 8080

position-info.eu@sensata.com

Asia Pacific

sales.isasia@list.sensata.com

China +86 (21) 2306 1500

Japan +81 (45) 277 7117

Korea +82 (31) 601 2004

India +91 (80) 67920890

Rest of Asia +886 (2) 27602006

ext 2808