

3-350820-2 ✓ ACTIVE

Ultra-Fast | Ultra-Fast 250

TE Internal #: 3-350820-2

Quick Disconnects, Receptacle, 16 – 14 AWG Wire Size, 1.31 – 2.08 mm<sup>2</sup> Wire Size, Mating Tab Width 6.35 mm [.25 in], Straight, Brass, Ultra-Fast 250

[View on TE.com >](#)



Terminals & Splices > Quick Disconnects

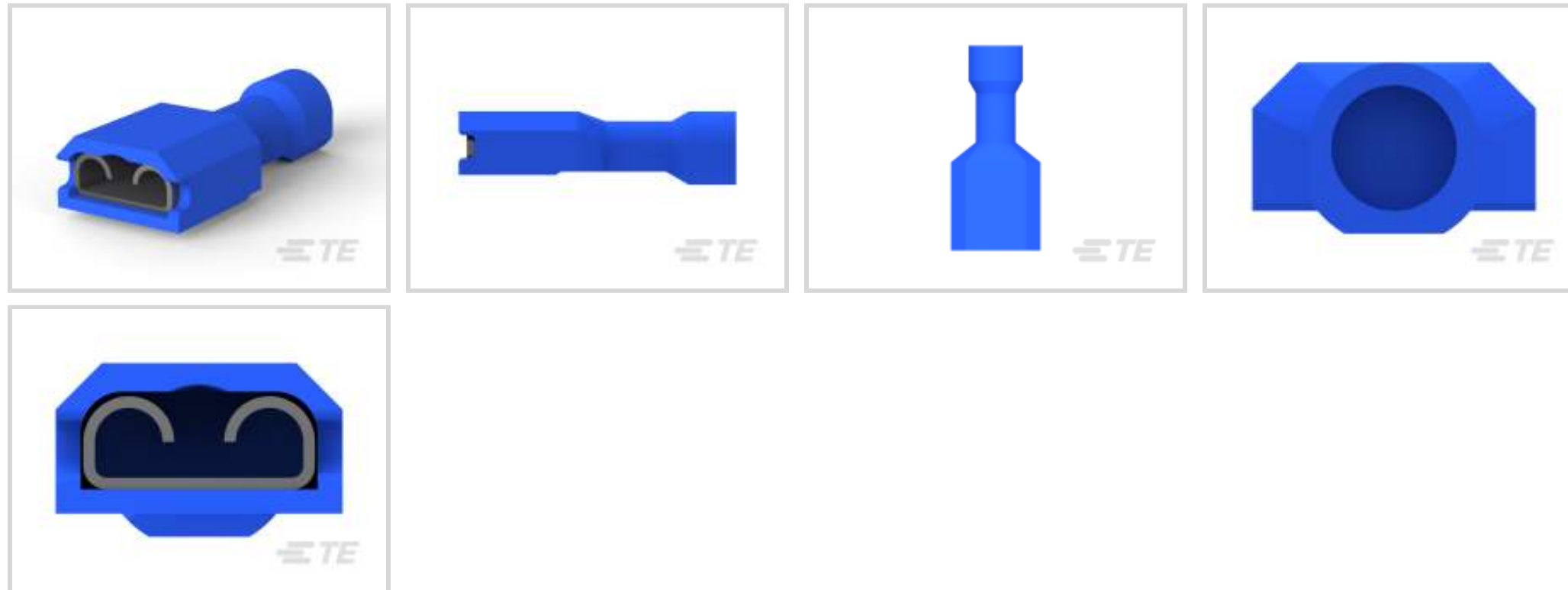

Quick Disconnect Terminal Type: **Receptacle**

Wire Size: 1.31 – 2.08 mm<sup>2</sup>

Mating Tab Width: 6.35 mm [.25 in]

Mating Tab Thickness: .81 mm [.032 in]

## Features

### Product Type Features

Terminal Features	Wire Stop
Insertion Force	Normal

### Configuration Features

Connection Capacity	Single
Compatible With Wire & Cable Type	Discrete Wire

### Electrical Characteristics

Voltage Rating	600 V
----------------	-------

### Body Features

Insulation Material	Nylon
---------------------	-------

### Contact Features

Quick Disconnect Terminal Type	Receptacle
Mating Tab Width	6.35 mm [.25 in]
Mating Tab Thickness	.81 mm [.032 in]
Terminal Orientation	Straight



Contact Base Material	Brass
Terminal Plating Material	Tin
Crimp Type	F-Crimp
Barrel Type	Closed

### Termination Features

Product Terminates To	Wire & Cable
-----------------------	--------------

### Mechanical Attachment

Wire Insulation Support	With
Mating Retention Type	Dimple

### Dimensions

Terminal Material Thickness	.41 mm[.016 in]
Product Length	21.75 mm[.855 in]
Compatible Insulation Diameter Range	4.06 mm[.16 in]
Wire Size	1.31 – 2.08 mm <sup>2</sup>

### Usage Conditions

Insulation Option	Fully Insulated
Operating Temperature Range	-40 – 110 °C[-40 – 230 °F]

### Industry Standards

Agency/Standard	UL
UL Flammability Rating	UL 94V-2

### Packaging Features

Packaging Quantity	1000
Packaging Method	Loose Piece/Carton

### Other

Barrel Color	Blue
--------------	------

### Product Compliance

[For compliance documentation, visit the product page on TE.com>](#)

EU RoHS Directive 2011/65/EU	Compliant
EU ELV Directive 2000/53/EC	Compliant
China RoHS 2 Directive MIIT Order No 32, 2016	No Restricted Materials Above Threshold
EU REACH Regulation (EC) No. 1907/2006	



Current ECHA Candidate List: JUNE 2023 (235)  
 Candidate List Declared Against: JUNE 2023 (235)  
 Does not contain REACH SVHC

Halogen Content  
 Low Halogen - Br, Cl, F, I < 900 ppm per homogenous material. Also BFR/CFR/PVC Free

Solder Process Capability  
 Not applicable for solder process capability

Product Compliance Disclaimer

This information is provided based on reasonable inquiry of our suppliers and represents our current actual knowledge based on the information they provided. This information is subject to change. The part numbers that TE has identified as EU RoHS compliant have a maximum concentration of 0.1% by weight in homogenous materials for lead, hexavalent chromium, mercury, PBB, PBDE, DBP, BBP, DEHP, DIBP, and 0.01% for cadmium, or qualify for an exemption to these limits as defined in the Annexes of Directive 2011/65/EU (RoHS2). Finished electrical and electronic equipment products will be CE marked as required by Directive 2011/65/EU. Components may not be CE marked. Additionally, the part numbers that TE has identified as EU ELV compliant have a maximum concentration of 0.1% by weight in homogenous materials for lead, hexavalent chromium, and mercury, and 0.01% for cadmium, or qualify for an exemption to these limits as defined in the Annexes of Directive 2000/53/EC (ELV). Regarding the REACH Regulation, the information TE provides on SVHC in articles for this part number is based on the latest European Chemicals Agency (ECHA) 'Guidance on requirements for substances in articles' posted at this URL: <https://echa.europa.eu/guidance-documents/guidance-on-reach>

### Compatible Parts

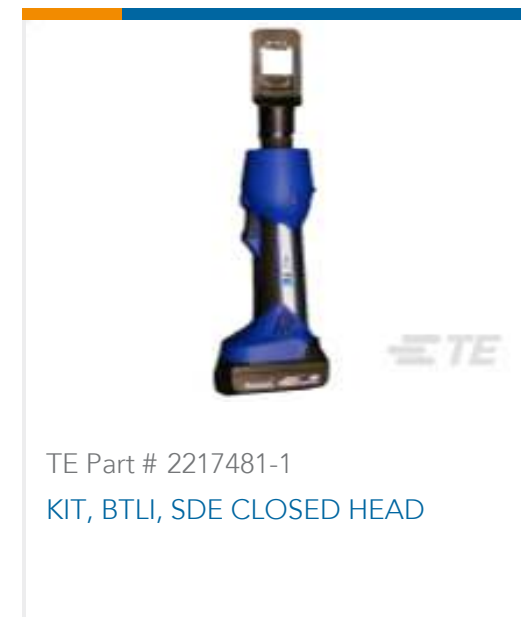
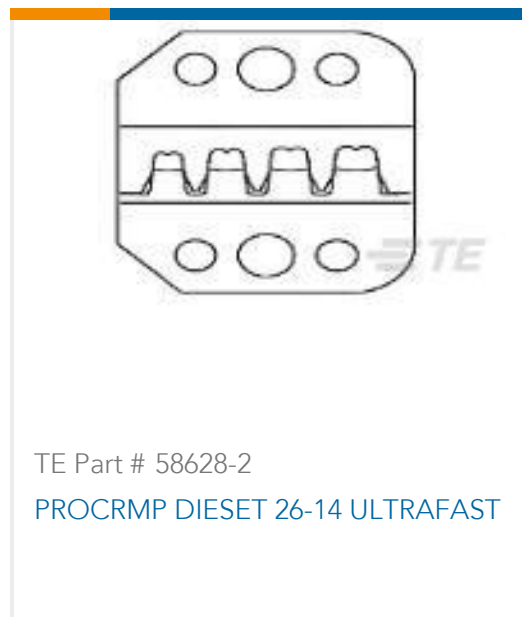

Also in the Series | **Ultra-Fast 250**



Automotive Housings(6)



Quick Disconnects(49)

## Customers Also Bought

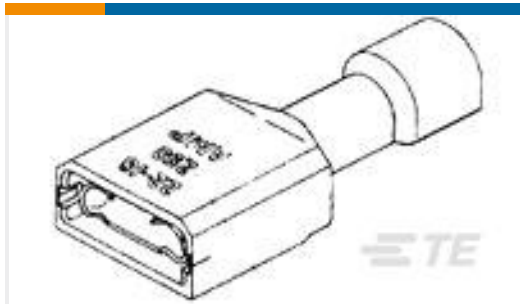

TE Part #4-520448-2  
ULTRAFAST 250 ASSY REC 12-10  
TPBR LP

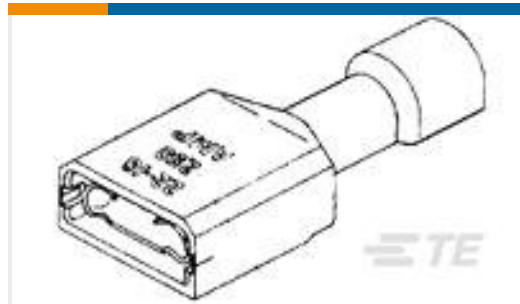

TE Part #3-350816-2  
ULTRAFAST 187 ASSY REC 16-14  
TPBR LP

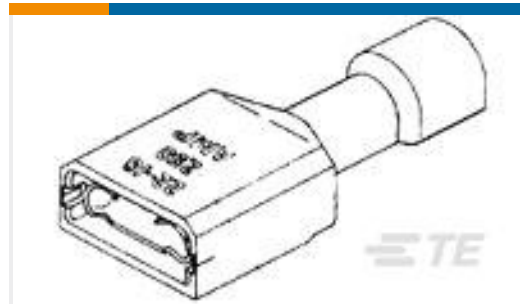

TE Part #3-520125-2  
ULTRAFAST 187 ASSY REC 16-14  
TPBR LP



TE Part #1-1393128-3  
PRD-5DG0-24=PRD

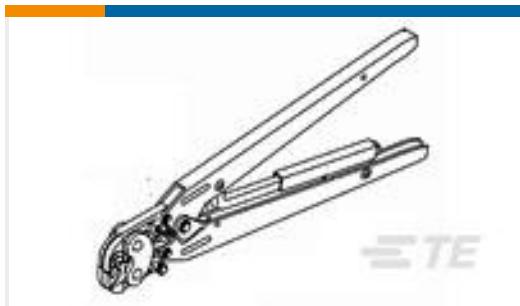

TE Part #90045  
DAHT 250 FASTON FLAG REC 18-14  
ASSY

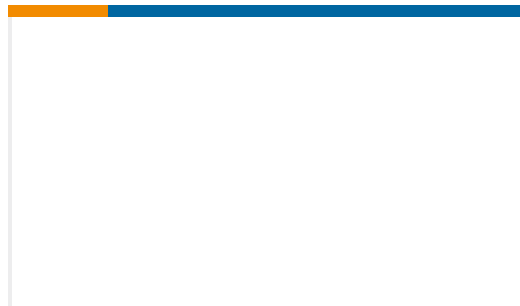

TE Part #302561  
TOGGLE LEVER



TE Part #1804311-1  
SCREW,ADJUSTMENT

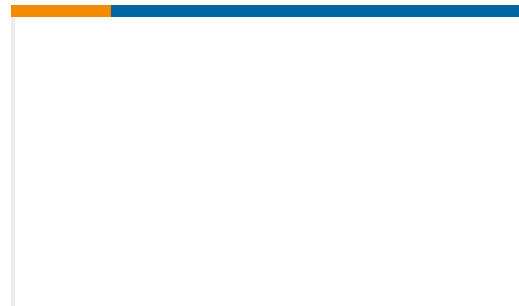

TE Part #300989  
RET. PIN

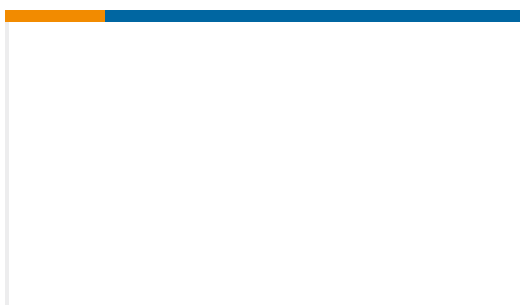

TE Part #300993  
WASHER

## Documents

### Product Drawings

[ULTRAFAST 250 ASSY REC 16-14 TPBR LP](#)

English

### CAD Files

[3D PDF](#)

[3D](#)

### Customer View Model

[ENG\\_CVM\\_CVM\\_3-350820-2\\_J.2d\\_dxf.zip](#)



English

**Customer View Model**

[ENG\\_CVM\\_CVM\\_3-350820-2\\_J.3d\\_igs.zip](#)

English

**Customer View Model**

[ENG\\_CVM\\_CVM\\_3-350820-2\\_J.3d\\_stp.zip](#)

English

By downloading the CAD file I accept and agree to the [Terms and Conditions](#) of use.

---

**Datasheets & Catalog Pages**

[Ultra-Fast and Ultra Fast Plus](#)

English

---

**Product Specifications**

[Application Specification](#)

English

[Application Specification](#)

English

---

**Product Environmental Compliance**

[Product Compliance Document](#)

English

[Product Compliance Document](#)

English

---

**Agency Approvals**

[UL](#)

English