

The CLC730116 evaluation board is designed to aid in the characterization of National's 6-pin, monolithic amplifiers, that are available in the SOT23-6 package.

The CLC730116 evaluation board is designed for non-inverting gains. Inverting gains or other circuit configurations can be obtained with slight modifications to the board. Use the evaluation board as a:

- Guide for high frequency layout
- Tool to aid in device testing and characterization

Basic Operation

Figure 1 shows the non-inverting schematic for the board. The input signal is brought into the board through a SMA connector to the non-inverting input of the amplifier. The resistor R_{in} is used to set the input termination resistance to the op amp. The non-inverting gain is set by the following equation:

$$\text{Non-inverting Gain} = 1 + R_f/R_g$$

The value of the feedback resistor, R_f , may have strong influence on AC performance. Refer to the product datasheet for feedback resistor selection. The output of the op amp travels through a series resistance, R_{out} , and then leaves the board through an SMA connector. The series resistance, R_{out} , matches transmission lines or isolates the output from capacitive loads. Tie "CTL" to the appropriate potential for normal or shutdown operation. (See product datasheet).

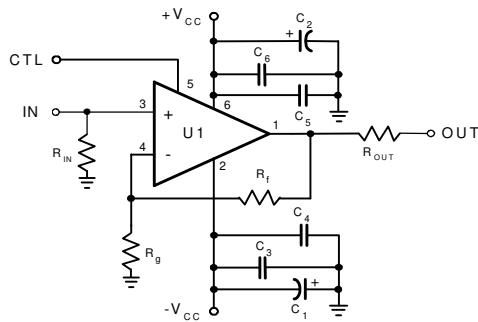

Figure 1: Non-Inverting Gain Configuration

Inverting Gain Operation

The evaluation board can be modified to provide an inverting gain configuration. Complete these steps to modify

1. Cut the input trace prior to pin 3.
2. Use a 25Ω resistor for R_{in} .
3. Terminate R_g at the input trace instead of ground.
4. Add R_f for desired input impedance (input impedance = $R_g || R_f$).

Figure 2 illustrates the inverting schematic for the board.

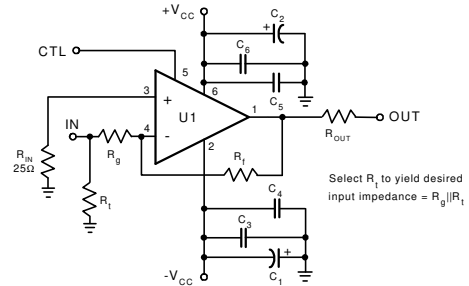

Figure 2: Inverting Gain Configuration

Layout Considerations

General layout and supply bypassing play major roles in high frequency performance. When designing your own board, use the evaluation board as a guide and follow these steps as a basis for high frequency layout:

1. Use a ground plane.
2. Include 6.8μF tantalum and 0.1μF ceramic capacitors on both supplies.
3. Place the 6.8μF capacitors within 0.75 inches of the power pins.
4. Place the 0.1μF capacitors less than 0.1 inches from the power pins.
5. Remove the ground plane under and around the part, especially near the input and output pins to reduce parasitic capacitance.
6. Minimize all trace lengths to reduce series inductance.
7. Use individual flush-mounted sockets for prototyping.

Measurement Hints

If 50Ω coax and 50Ω R_{in}/R_{out} resistors are used, many of the typical performance plots found in the product datasheet can be reproduced.

When SMA connectors and cables are not available to evaluate the amplifier, do not use normal oscilloscope probes. Use low impedance resistive divider probes of 100 to 500Ω. If a low impedance probe is not available, then a section of 50Ω coaxial cable and a low impedance resistor (10Ω to 50Ω) may be used.

Follow these 3 steps to create a "cable/resistor" probe:

1. Connect one end of the coax's center to a test measurement box terminated in 50Ω
2. Connect the other end of the cable's center conductor to the low impedance resistor. (The open side of the resistor is now the probe).
3. Connect the ground shield of the cable to the evaluation board around and test box around.

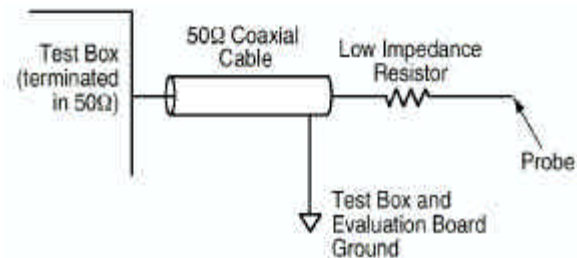
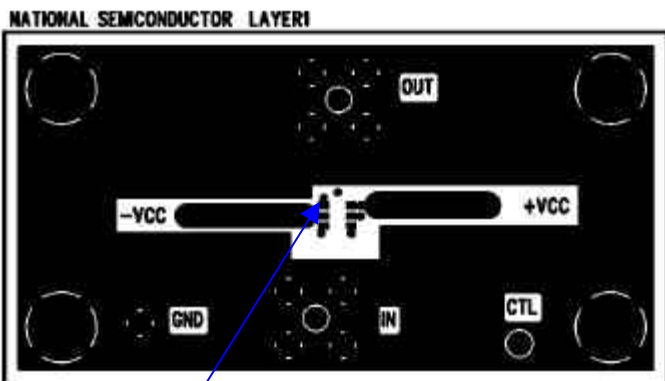

Figure 3: "Cable/Resistor" Probe Configuration

This "cable/resistor" probe, shown in Figure 3, forms a voltage attenuator between the resistor and the 50Ω termination resistance of the test box. This method allows measurements to be performed directly on the output pin of the amplifier.



Pin 1 Note: Device installed on circuit side of board

Sot23-6 Evaluation Board – Layer 1

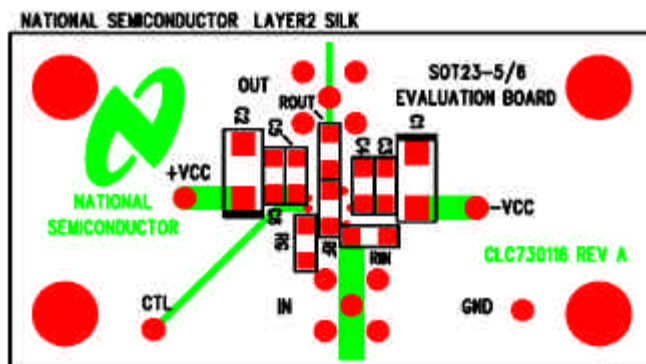

SOT23-6 Evaluation Board – Layer 2

Power Supplies

Refer to the product datasheet for the recommended supply voltages.

Component Values

- R_f, R_g – Use the product datasheet to select values.
- R_{in}, R_{out} - 50Ω (Refer to **Basic Operation** section for details).
- R_t – Optional resistor for inverting gain configurations. (Refer to **Inverting Gain Operation** section for details).
- C_1, C_2 – 6.8μF tantalum capacitors.
- C_3, C_6 – 0.1μF ceramic capacitors.
- C_4, C_5 – 0.01μF ceramic capacitors (optional)

LIFE SUPPORT POLICY

NATIONAL'S PRODUCTS ARE NOT AUTHORIZED FOR USE AS CRITICAL COMPONENTS IN LIFE SUPPORT DEVICES OR SYSTEMS WITHOUT THE EXPRESS WRITTEN APPROVAL OF THE PRESIDENT AND GENERAL COUNSEL OF NATIONAL SEMICONDUCTOR CORPORATION. As used herein:

1. Life support devices or systems are devices or systems which, (a) are intended for surgical implant into the body, or (b) support or sustain life, and whose failure to perform when properly used in accordance with instructions for use provided in the labeling, can be reasonably expected to result in a significant injury to the user.
2. A critical component is any component of a life support device or system whose failure to perform can be reasonably expected to cause the failure of the life support device or system, or to affect its safety or effectiveness.

National Semiconductor Corporation Americas
 Tel: 1-800-272-9959
 Fax: 1-800-737-7018
 Email: support@nsc.com

National Semiconductor Europe
 Fax: +49 (0) 180-530-85 86
 Email: europe.support@nsc.com
 Deutsch Tel: +49 (0) 69 9508 6208
 English Tel: +44 (0) 870 24 0 2171
 Francais Tel: +33 (0) 1 41 91 8790

National Semiconductor Asia Pacific Customer Response Group
 Tel: 65-2544466
 Fax: 65-2504466
 Email: ap.support@nsc.com

National Semiconductor Japan Ltd.
 Tel: 81-3-5639-7660
 Fax: 81-3-5639-7507

National does not assume responsibility for use of any circuitry described, no circuit patent licenses are implied and National reserves the right at any time without notice to change said circuitry and specifications.