

Sub PMIC with Dual-Output Boost Converter with I²C Interface for Flash LED and Backlight LED, Dual-Output LCD Bias and DVS

Purpose

RT4832A is an integrated total power solution for Flash LED Driver, Backlight WLED Driver, and DSV Driver. This document explains the function and use of the RT4832A evaluation board (EVB), and provides information to enable operation, modification of the evaluation board and circuit to suit individual requirements.

Table of Contents

Purpose	1
Introduction.....	2
Bench Test Setup Conditions	4
Schematic, Bill of Materials & Board Layout	5
More Information.....	9
Important Notice for Richtek Evaluation Board	9

Introduction

General Product Information

RT4832A is an integrated total power solution for Flash LED Driver, Backlight WLED Driver, and DSV Driver. Flash LED Driver provides up to 2-CH 1.5A applications. Back Light WLED Driver supports up to 36V output for 10 WLEDs applications. And it provides 1024 steps LED current with logarithmic/linear curve. DSV is implemented by one single inductor boost and inverting charge pump, which provide customers minimum EVB Area compared to dual inductors. The negative output power (CPOUT) comes from boost output (LCMOUT). It also provides DSV positive voltage (POS), which power noise is reduce by passing though LDO. Their ranges can be programmed from $\pm 4V$ to $\pm 6V$ per 50mV step respectively. Flash Boost Converter operates at 2MHz/4MHz frequency. The 4MHz frequency solution allows tinny and low-profile components. Torch Mode Current can be set from 25mA to 375mA per 25mA Step. And Strobe Mode Current range is from 100mA to 1.5A per 100mA Step.

DSV drives TFT-LCD panels up to 10" (from SFF to MFF like tablets). These two output rails are usually connected to Source Driver IC. Wide input voltage range from 2.5V to 5.5V optimizes the single-cell battery applications (Li-Ion, Ni-Li, Li-Polymer) and which symmetrical output current is up to 80mA.

The RT4832A provides complete protection such as VIN under voltage lockout, Vin monitor protection, over current protection, over voltage protection, LED short protection, VOUT short protection and over temperature protection.

RT4832A is available in WL-CSP-30B 2.24x2.64 (BSC) package.

Product Feature

- **Input Voltage Range: 2.5V to 5.5V**
- **Internal Soft-start, UVLO, OTP, OCP**
- **Typical Shutdown Current: < 1 μ A**
- **-40 to +85°C Temperature Range**
- **2CH Back Light LED Driver**
 - ◆ **Drives up to 10 WLEDs in Two Strings**
 - ◆ **External PWM Pin Control and I²C Programmable 11 bit Linear and Exponential Brightness**
 - ◆ **LED Current Accuracy $\pm 5\%$ (>500 μ A), $\pm 3\%$ (>5mA)**
 - ◆ **I²C Programmable OVP 18/22/25/29/33/36V**
- **2CH Flash LED Driver**
 - ◆ **Torch Mode Current from 25mA to 375mA per 25mA Step with 2 channels**
 - ◆ **Strobe Mode Current from 100mA to 1.5A per 100mA Step with 2 channels**
 - ◆ **I²C Programmable Flash Safety Timer from 32msec to 1024msec per 32msec Step**
 - ◆ **High Accurate Safety Timer $\pm 10\%$, Current Accuracy $\pm 4\%$ (>375mA), Current Matching $\pm 7\%$ (>375mA)**
 - ◆ **VIN Monitor Protection from 2.5V to 3.2V per 0.1V Step**
 - ◆ **Selectable Input Current Limit 1.9A /2.8A**
 - ◆ **2MHZ/4MHZ Switching Frequency for Flash LED**
 - ◆ **Flash LED1/2 Short Protection, and Output Short Protection**
 - ◆ **Txmask Protection by Independent Pin**
- **DSV**
 - ◆ **I²C Programmable Output Voltages**
 - ◆ **Flexible Boost Voltage, POS, CPOUT Default Setting**
 - ◆ **Regulated Voltage Output: 4V to 6V per 50mV Step**

- ◆ Positive Voltage Output: 4V to 6V per 50mV Step
- ◆ Negative Voltage Output: -4V to -6V per 50mV Step
- ◆ User Selectable Output Fast Discharge Mode or Float Mode when turned off
- ◆ Independent Positive and Negative Enable Control by Two External Pins
- ◆ True Load Disconnect, OCP, and Positive/Negative SCP Function

Key Performance Summary Table

Key Features	Evaluation Board Number: PCB092_V1
Input Voltage Range	2.5V ~ 5.5V
Flash LED Strobe Current*	25mA ~ 375mA
Flash LED Torch Current*	0.1A ~ 1.5A
LED OVP Voltage*	18V ~ 36V
LED Output Current*	0 ~ 25mA
POS Voltage*	4V ~ 6V
CPOUT Voltage*	-6V ~ -4V

Bench Test Setup Conditions

Headers Description and Placement

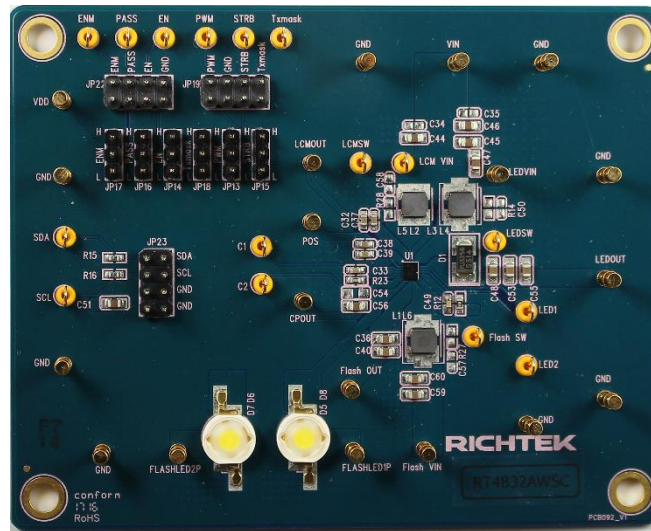

Carefully inspect all the components used in the EVB according to the following Bill of Materials table, and then make sure all the components are undamaged and correctly installed. If there is any missing or damaged component, which may occur during transportation, please contact our distributors or e-mail us at evb_service@richtek.com.

Test Points

The EVB is provided with the test points and pin names listed in the table below.

Test point/ Pin name	Signal	Comment (expected waveforms or voltage levels on test points)
VIN	Input voltage	Power input. Support 2.5V to 5.5V Input Voltage. Must bypass with a suitable large ceramic capacitor at this pin.
LCMOUT	Enable test point	DSV boost converter output pin.
POS	Output point	DSV positive output pin.
CPOUT	Output point	DSV negative output pin.
LCMSW	Switch node test point	Switching node of DSV boost converter. Connect a 2.2 μ H inductor between LCMSW and VIN.
LEDSW	Switch node test point	Switch node of boost converter. Connect a 4.7 μ H to 10 μ H inductor between LEDSW and VIN.
LEDOUT	Output point	Backlight boost converter output pin.
LED1	Input point	Backlight current sink 1.
LED2	Input point	Backlight current sink 2.
Flash SW	Switch node test point	Drain connection for internal N-MOSFET and synchronous P-MOSFET switches. Connect a 0.47 μ H to 1 μ H inductor between FlashSW and VIN.
Flash OUT	Output point	Flash boost converter output pin.
FLASHILED1S	Output point	Flash current source 1.
FLASHILED2S	Output point	Flash current source 2.
GND	Ground	Ground.

Power-up & Measurement Procedure

1. Connect input power ($2.5V < V_{IN} < 5.5V$) and connect the EN pin to H level for the chip enable.
2. The slave address is 7b'0x11. Check the register table and modify it if need.
3. Write 0x0C = 0x48 to enable the DSV. Write 0x0A = 0x19 to enable backlight. Write 0x0A = 0x02 to enable flash LED.

Schematic, Bill of Materials & Board Layout

EVB Schematic Diagram

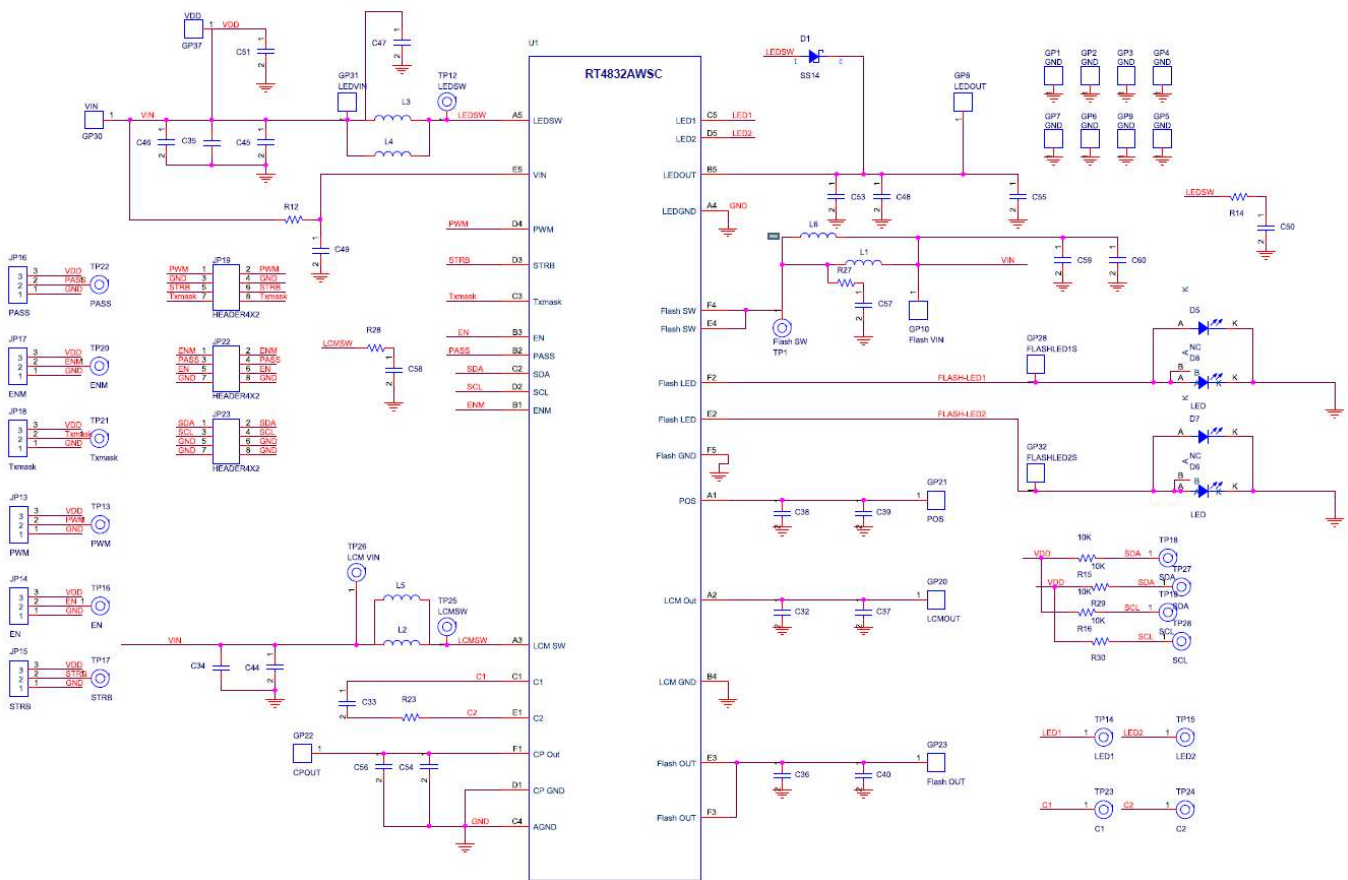

Bill of Materials

Reference	Qty	Part number	Description	Package	Manufacture
U1	1	RT4832AWSC	Boost Converter	WL-CSP-30B 2.24x2.64	RICHTEK
C32, C37, C38, C39	4	GRM188R61C475KAAJD	4.7μF/16V/X5R/0603	C-0603	MuRata
C33	1	C1608X5R1E105KT000E	1μF/25V/X5R/0603	C-0603	TDK
C36, C40, C48, C53, C55, C59, C60	7	CGA4J3X5R1H475K125AB	4.7μF/50V/X5R/0805	C-0805	TDK
C44, C45, C46, C47, C51, C56	6	C2012X5R1C106KT	10μF/16V/X5R/0805	C-0805	TDK
C49	1	0603B103K500	10nF/16V/X7R/0603	C-0603	WALSIN
D1	1	SS14	SS14	D-D	PANJIT
D6, D8	2	P2000L-W2O1-A1J11H	Flash LED	P2O_LED_2	SemiLED
L3	1	NR4018T100M	10μH	4.0*4.0	TAIYO YUDEN
L5	1	NR4018T2R2M	2.2μH	4.0*4.0	TAIYO YUDEN
L6	1	NR4018T1R0N	1μH	4.0*4.0	TAIYO YUDEN
R12	1	WR06X1500FTL	150/0603/ ±1%	R-0603	WALSIN
R15, R16	2	WR06X1002FTL	10K/0603/ ±1%	R-0603	WALSIN
R23	1	WR06X000 PTL	0/0603 / ±1%	R-0603	WALSIN

PCB Layout

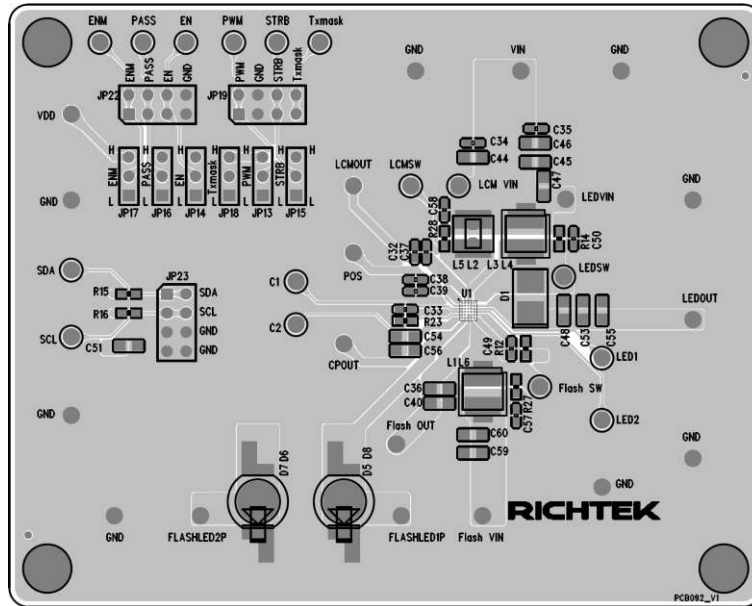

Top View (1st layer)

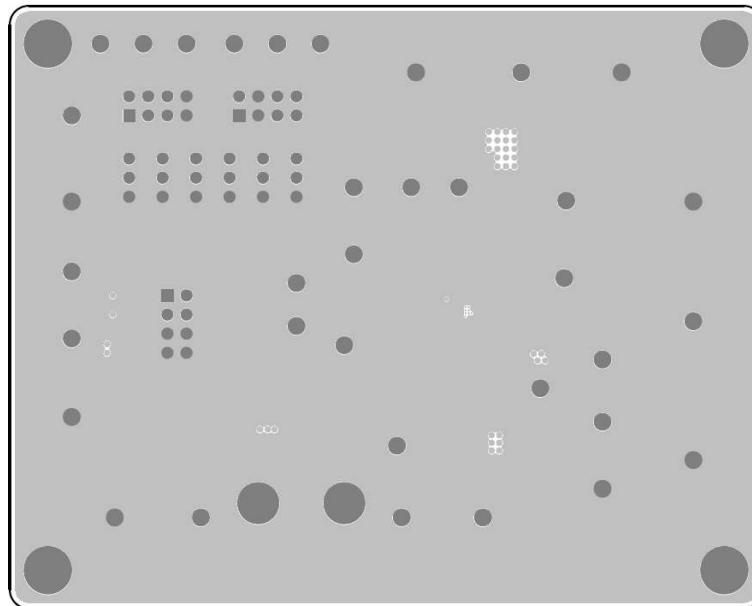

PCB Layout—Inner Side (2nd Layer)

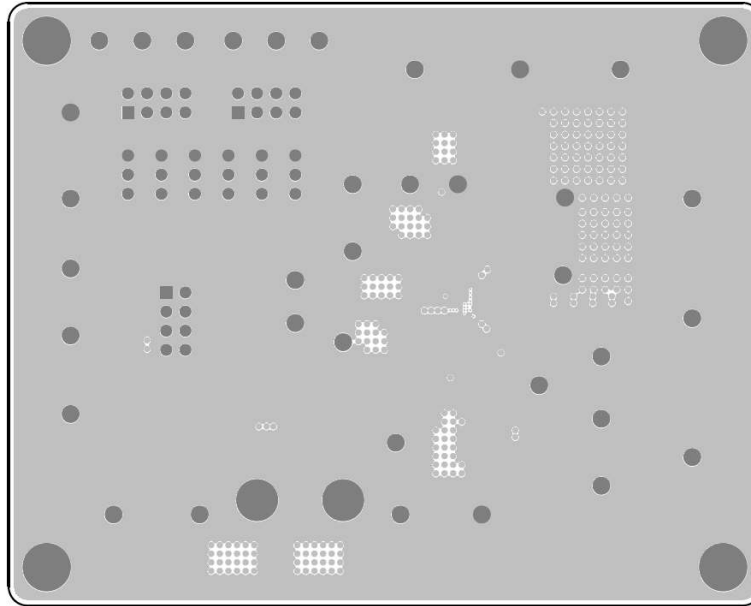

PCB Layout—Inner Side (3rd Layer)

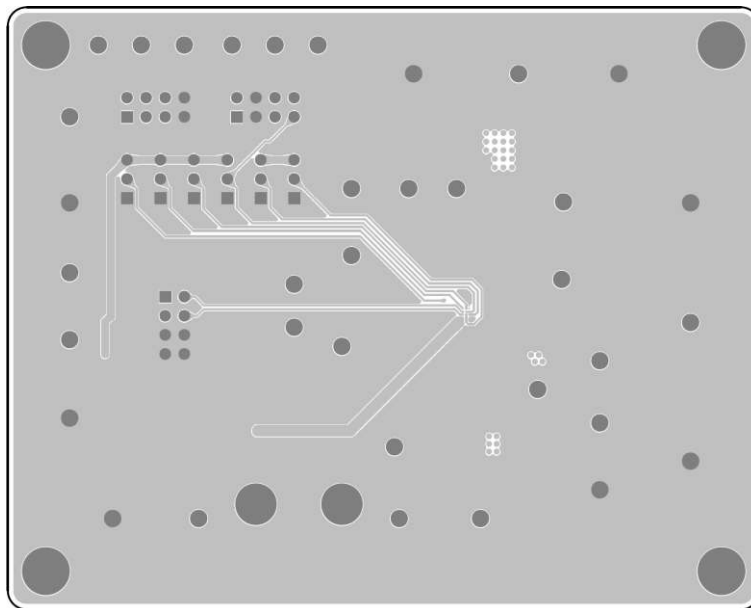

Bottom View (4th Layer)

More Information

For more information, please find the related datasheet or application notes from Richtek website <http://www.richtek.com>.

Important Notice for Richtek Evaluation Board

THIS DOCUMENT IS FOR REFERENCE ONLY, NOTHING CONTAINED IN THIS DOCUMENT SHALL BE CONSTRUED AS RICHTEK'S WARRANTY, EXPRESS OR IMPLIED, UNDER CONTRACT, TORT OR STATUTORY, WITH RESPECT TO THE PRESENTATION HEREIN. IN NO EVENT SHALL RICHTEK BE LIABLE TO BUYER OR USER FOR ANY AND ALL DAMAGES INCLUDING WITHOUT LIMITATION TO DIRECT, INDIRECT, SPECIAL, PUNITIVE OR CONSEQUENTIAL DAMAGES.