

PRODUCT DATA DRAWING

MATERIAL :

BODY,
BUSHING &
PRESS SLEEVE: STAINLESS STEEL PER AMS-5640
ALLOY UNS S30300, TYPE I

CONTACTS,
E-RING,
SPRING CLIP &
SHIM SPRING: BERYLLIUM COPPER PER ASTM B196,
ALLOY UNS C17300, TD04

BODY: BRASS PER ASTM B16,
ALLOY UNS C36000, H02

INSULATOR: PTFE PER ASTM D1710, TYPE I, GRADE 1, CLASS B

INSULATOR: KEL-F

COIL SPRING: CARBON STEEL MUSIC WIRE

RESISTOR ELEMENT: ALUMINUM NITRIDE SUBSTRATE WITH
TANTALUM NITRIDE RESISTOR; GOLD
PLATED TERMINATIONS

FINISH :

BODIES,
CONTACTS,
INSERT,
SHIM SPRING &
SPRING CLIP: GOLD PER ASTM B488, TYPE I,
CODE C, CLASS 0; OVER NICKEL
PER AMS-QQ-N-290, CLASS 1, .000050" MIN.

CONTACT: GOLD PER ASTM B488, TYPE II,
CODE C, CLASS 1.27; OVER NICKEL
PER AMS-QQ-N-290, CLASS 1, .000050" MIN.

E-RING: NICKEL PER AMS-QQ-N-290,
CODE G, CLASS 1

SPRING: ZINC

PERFORMANCE :

IMPEDANCE: 50 OHMS
FREQ. RANGE: DC TO 12.0 GHz
VSWR: 1.20:1 DC TO 12 GHz
AVG. POWER: 1 WATT (NOTE 1)

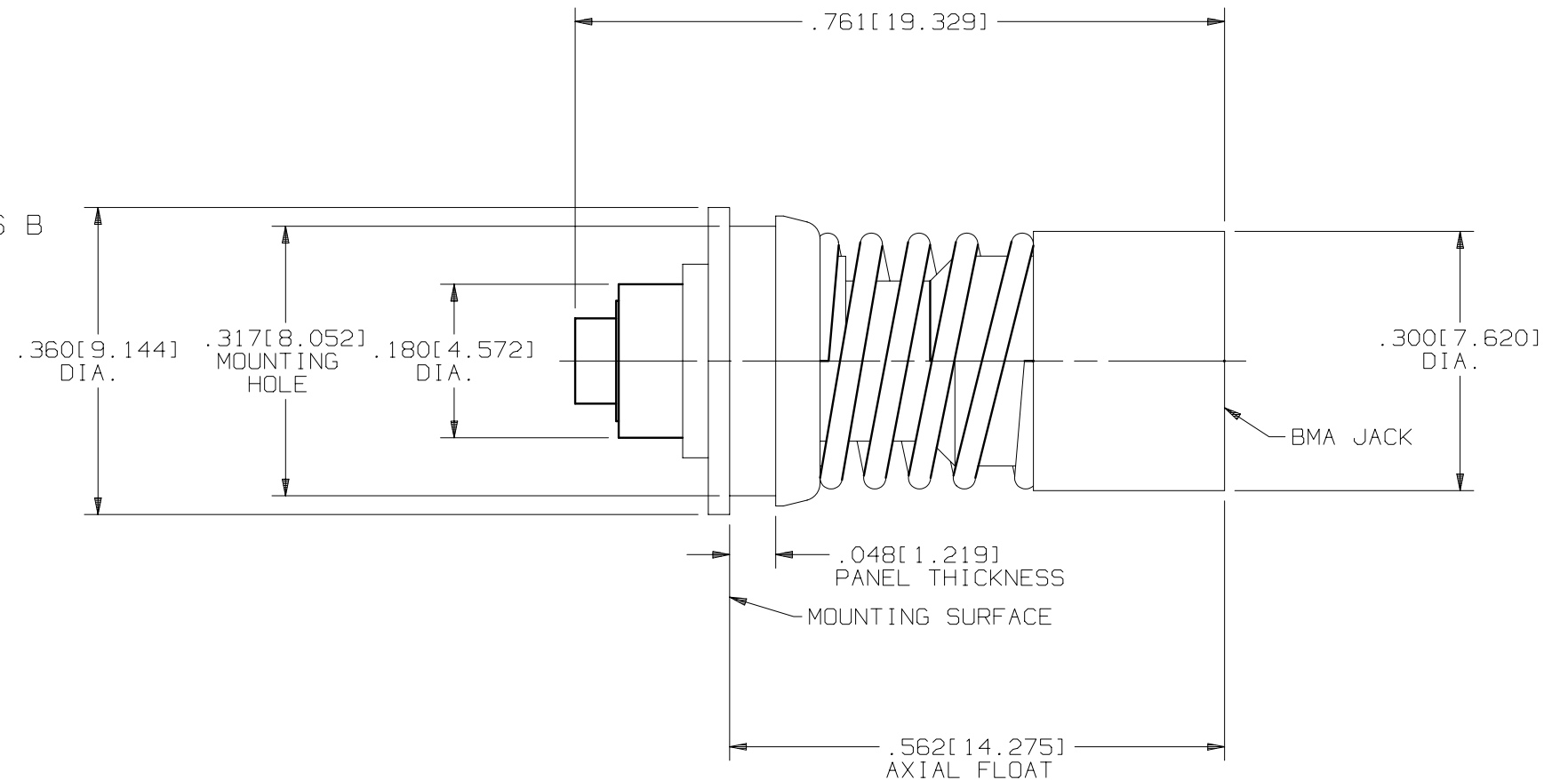

NOTES:

1. POWER INPUT DERATED LINEARLY FROM 25°C TO .5 WATTS AT 125°C.

SYM.	DESCRIPTION	DATE	APPR.	UNLESS OTHERWISE SPECIFIED: 1) ALL DIMENSIONS ARE AFTER PLATING. 2) BREAK CORNERS & EDGES .005 R. MAX. 3) CHAM. 1s1 & LAST THDS. 4) SURFACE ROUGHNESS 63 / MIL-STD-10. 5) DIAS. ON COMMON CENTERS TO BE CONCENTRIC WITHIN .005 T.I.R. 6) REMOVE ALL BURRS.	DIMENSIONS ARE IN INCHES TOLERANCES:			SV Microwave, Inc. 2400 Centrepark West Drive, Suite 100 West Palm Beach, FL 33409
				DECIMALS .X ±.030 .XX ±.015 .XXX ±.005	FRACTIONAL ±1/64	ANGULAR X° ±1°0' X°X' ±15'	TITLE:	
-	REL.DCN 29339	01/03	STW		MATERIAL: SEE ABOVE			BMA JACK FLOATING MOUNT TERMINATION
A	REV.DCN 32953	04/05	CCC		FINISH: SEE ABOVE			
B	REV.DCN 33116	06/05	CCC		SIZE	CAGE NO.	SCALE	DWG. NO.
				DRAWN: MEB 01/06/03	B	95077	5X	8017-6002
				CHECKED: STW 01/06/03				
				APPROVED: STW 01/06/03				