

# TPS56121 Step-Down Converter Evaluation Module User's Guide



## Table of Contents

<b>1 Introduction</b> .....	3
<b>2 Description</b> .....	4
2.1 Applications.....	4
2.2 Features.....	4
<b>3 Electrical Performance Specifications</b> .....	5
<b>4 Schematic</b> .....	6
<b>5 Test Setup</b> .....	7
5.1 Test Equipment.....	7
5.2 Recommended Wire Gauge.....	7
5.3 Equipment Set Up Procedure.....	8
<b>6 Configurations</b> .....	9
6.1 Enable Selection (J3).....	9
<b>7 Test Point Descriptions</b> .....	10
7.1 Input Voltage Monitoring (TP1 and TP2).....	10
7.2 Output Voltage Monitoring (TP3 and TP4).....	10
7.3 Enable/Soft-start Monitoring (TP5).....	10
7.4 Power Good Monitoring (TP6).....	10
7.5 Loop Response Testing (TP7, TP8, TP9 and TP10).....	10
7.6 Switch Node Voltage Monitoring (TP11 and TP12).....	10
<b>8 Test Procedures</b> .....	11
8.1 Start Up/Shut Down Procedure.....	11
8.2 Output Ripple Voltage Measurement Procedure.....	11
8.3 Control Loop Gain and Phase Measurement Procedure.....	12
8.4 Equipment Shutdown.....	12
<b>9 Performance Data and Typical Characteristic Curves</b> .....	13
9.1 Efficiency.....	13
9.2 Load Regulation.....	13
9.3 Line Regulation.....	14
9.4 Output Voltage Ripple.....	14
9.5 Switch Node.....	15
9.6 Load Transient.....	15
9.7 Start Up.....	16
9.8 Power Off.....	17
9.9 Over-Current Protection.....	17
9.10 Control Loop Bode Plot.....	18
9.11 Thermal Image.....	18
<b>10 EVM Assembly Drawings and PCB Layout</b> .....	19
<b>11 List of Materials</b> .....	22
<b>12 Revision History</b> .....	22

## List of Figures

Figure 4-1. TPS56121EVM-601 Schematic.....	6
Figure 5-1. TPS56121EVM-601 Recommended Test Setup.....	8
Figure 8-1. Tip and Barrel Output Voltage Ripple Measurement.....	11
Figure 8-2. Control Loop Measurement Setup.....	12
Figure 9-1. Efficiency.....	13
Figure 9-2. Load Regulation.....	13
Figure 9-3. Line Regulation (VIN = 8 V to 14 V, VOUT = 1.0 V, IOU = 15 A).....	14
Figure 9-4. Output Voltage Ripple (VIN = 12 V, VOUT = 1.0 V, IOU = 15 A).....	14

Figure 9-5. Switch Node Waveform Measured at Pins Using Tip and Barrel Measurement Technique (VIN = 12 V, VOUT = 1.0 V, IOU = 15 A).....	15
Figure 9-6. Load Transient (VIN = 12 V, VOUT = 1.0 V, IOU = 0 A to 15 A).....	15
Figure 9-7. Start-Up Waveform (VIN = 12 V, VOUT = 1.0 V, IOU = 15 A).....	16
Figure 9-8. Pre-Biased Start-Up Waveform (VIN = 12 V, VOUT = 1.0 V, IOU = 0 A).....	16
Figure 9-9. Power-Off Waveform (VIN = 12 V, VOUT = 1.0 V, IOU = 15 A).....	17
Figure 9-10. Over-Current Protection Waveform (Ch1: VIN, Ch2: EN/SS, Ch3: VOUT, Ch4: IOU (10 A/div), VIN = 12 V, VOUT = 1.0 V, IOU = 23 A).....	17
Figure 9-11. Loop Gain (VIN = 12 V, VOUT = 1.0 V, IOU = 15 A, Bandwidth: 39 kHz, Phase Margin: 46°).....	18
Figure 9-12. Thermal Image (VIN = 14 V, VOUT = 1.0 V, IOU = 15 A, without airflow).....	18
Figure 10-1. TPS56121EVM-601 Top Assembly Drawing (top view).....	19
Figure 10-2. TPS56121EVM-601 Bottom Assembly Drawing (bottom view).....	19
Figure 10-3. TPS56121EVM-601 Top Copper (top view).....	20
Figure 10-4. TPS56121EVM-601 Internal 1 (top view).....	20
Figure 10-5. TPS56121EVM-601 Internal 2 (top view).....	21
Figure 10-6. TPS56121EVM-601 Bottom Copper (top view).....	21

### List of Tables

Table 3-1. TPS56121EVM-601 Electrical Performance Specifications.....	5
Table 7-1. Test Point Descriptions.....	10
Table 11-1. TPS56121EVM-601 List of Materials.....	22

### Trademarks

All trademarks are the property of their respective owners.

## 1 Introduction

The TPS56121EVM-601 evaluation module (EVM) is a synchronous buck converter providing a fixed 1.0-V output at up to 15 A from a 12-V input bus. The EVM is designed to start up from a single supply; so, no additional bias voltage is required for start up. The module uses the TPS56121 High-Current Synchronous Buck Converter with integrated MOSFETs.

The TPS56121 integrates TI's high performance controller technology with TI's industry leading MOSFET technology in a standard QFN package to meet the demands of modern, high-current, and space constrained applications.

## 2 Description

TPS56121EVM-601 is designed to use a regulated 12-V (8-V to 14-V) bus voltage to provide a regulated 1.0-V output at up to 15 A of load current. TPS56121EVM-601 is designed to demonstrate the TPS56121 high-current integrated FET converter in a typical space-limited, 12-V bus to low-voltage point-of-load application.

### 2.1 Applications

- High-Current, Low-Voltage FPGA or Micro Controller Core Supplies
- High-Current Point-of-Load Modules
- Telecommunications Equipment
- Computer Peripherals

### 2.2 Features

- 8-V to 14-V Input Voltage Rating
- 1.0-V  $\pm 2\%$  Output Voltage Rating
- 15-A Steady-State Load Current
- 500-kHz Switching Frequency
- Simple Access to Power Good, Enable/Soft-Start and Error Amplifier
- Convenient Converter Performance Test Points

### 3 Electrical Performance Specifications

**Table 3-1. TPS56121EVM-601 Electrical Performance Specifications**

PARAMETER		TEST CONDITIONS	MIN	TYP	MAX	UNIT
<b>Input Characteristics</b>						
$V_{IN}$	Input voltage		8	12	14	V
$I_{IN}$	Input current	$V_{IN} = 12\text{ V}$ , $I_{OUT} = 15\text{ A}$		1.40		A
	No load input current	$V_{IN} = 12\text{ V}$ , $I_{OUT} = 0\text{ A}$		43		mA
$V_{IN\_UVLO}$	Input UVLO	$I_{OUT} = 15\text{ A}$		4.2		V
<b>Output Characteristic</b>						
$V_{OUT}$	Output voltage	$V_{IN} = 8\text{ V to }14\text{ V}$ , $I_{OUT} = 0\text{ A to }15\text{ A}$	0.98	1.0	1.02	V
	Line regulation	$V_{IN} = 8\text{ V to }14\text{ V}$ , $I_{OUT} = 15\text{ A}$		0.1%		
	Load regulation	$V_{IN} = 12\text{ V}$ , $I_{OUT} = 0\text{ A to }15\text{ A}$		0.5%		
$V_{RIPPLE}$	Output voltage ripple	$V_{IN} = 12\text{ V}$ , $I_{OUT} = 15\text{ A}$		20		mV <sub>pp</sub>
$I_{OUT}$	Output current	$V_{IN} = 8\text{ V to }14\text{ V}$	0		15	A
<b>Systems Characteristics</b>						
$f_{SW}$	Switching frequency		450	500	550	kHz
$\eta_{pk}$	Peak efficiency	$V_{IN} = 12\text{ V}$ , $I_{OUT} = 13\text{ A}$		90.5%		
$\eta$	Full-load efficiency	$V_{IN} = 12\text{ V}$ , $I_{OUT} = 15\text{ A}$		90.4%		
	Operating temperature			25		°C

## 4 Schematic

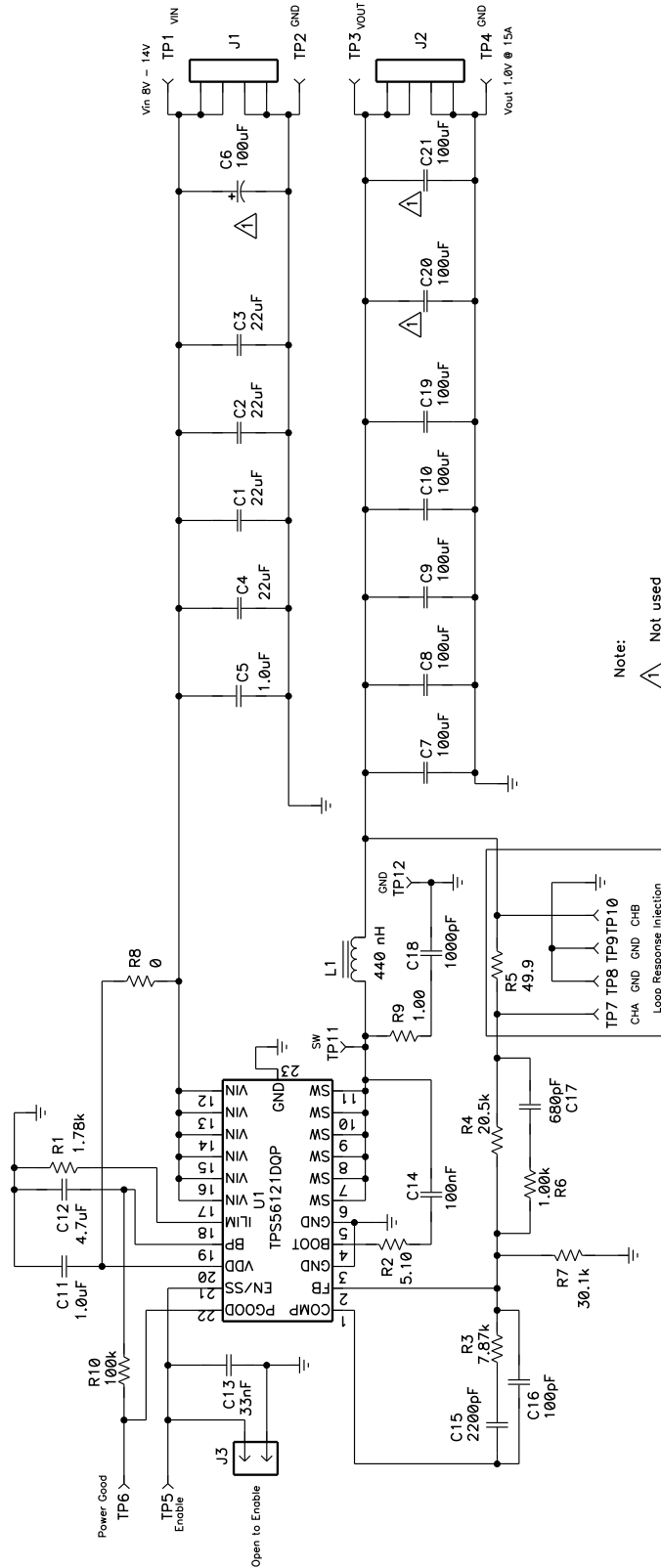

Figure 4-1. TPS56121EVM-601 Schematic

## 5 Test Setup

### 5.1 Test Equipment

#### 5.1.1 Voltage Source

**VIN:** The input voltage source (VIN) shall be a 0-V to 15-V variable DC source capable of supplying 2.5 A<sub>DC</sub>.

#### 5.1.2 Meters

- **A1:** Input current meter (0 A<sub>DC</sub> to 2.5 A<sub>DC</sub>).
- **V1:** Input voltage meter (0 V to 15 V).
- **V2:** Output voltage meter (0 V to 2 V).

#### 5.1.3 Load

**LOAD:** Output load. Electronic load set for constant current or constant resistance mode, capable of 0 A<sub>DC</sub> to 15 A<sub>DC</sub> at 1.0 V<sub>DC</sub>.

#### 5.1.4 Oscilloscope

**For Output Voltage Ripple:** Oscilloscope shall be an analog or digital oscilloscope set for AC coupled measurement with 20-MHz bandwidth limiting. Use 20-mV/div vertical resolution, 1.0-μs/div horizontal resolution.

**For Switching Waveforms:** Oscilloscope shall be an analog or digital Oscilloscope set for DC coupled measurement with 20-MHz bandwidth limiting. Use 2-V/div or 5-V/div vertical resolution and 1.0-μs/division horizontal resolution.

#### 5.1.5 Fan

The TPS56121EVM-601 Evaluation Module includes components that can get hot to touch when operating. Because this evaluation module is not enclosed to allow probing of circuit nodes, a small fan capable of 200 lfm to 400 lfm is recommended to reduce component temperatures when operating.

## 5.2 Recommended Wire Gauge

### 5.2.1 VIN to J1

The connection between the source voltage (VIN) and J1 of TPS56121EVM-601 can carry as much as 2.5 A<sub>DC</sub> of current. The minimum recommended wire size is AWG #16 with the total length of wire less than 2 feet (1 foot input, 1 foot return)

### 5.2.2 J2 to LOAD

The connection between the LOAD and J2 of TPS56121EVM-601 can carry as much as 15 A<sub>DC</sub> of current. The minimum recommended wire size is 2xAWG #14 with the total length of wire less than 2 feet (1 foot input, 1 foot return).

### 5.3 Equipment Set Up Procedure

Figure 5-1 is the recommended test setup to evaluate the TPS56121EVM-601.

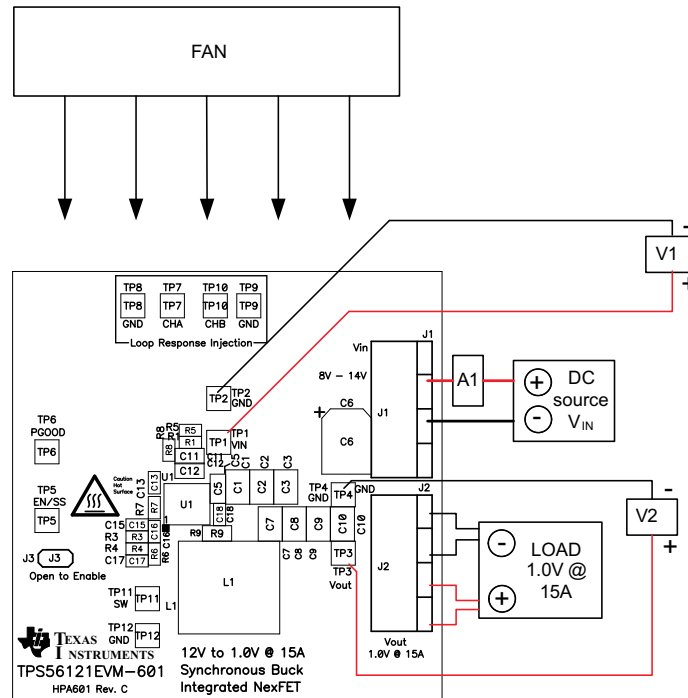

**Figure 5-1. TPS56121EVM-601 Recommended Test Setup**

1. Working at an ESD workstation, make sure that any wrist straps, bootstraps and mats are connected referencing the user to earth ground before power is applied to the EVM. Wearing electrostatic smock and safety glasses is also recommended.
2. Prior to connecting the DC input source,  $V_{IN}$ , it is advisable to limit the source current from  $V_{IN}$  to 3.0 A maximum. Make sure  $V_{IN}$  is initially set to 0 V and connected as shown in Figure 5-1.
3. Connect  $V_{IN}$  to J1 as shown in Figure 5-1.
4. Connect ammeter A1 between  $V_{IN}$  and J1 as shown in Figure 5-1.
5. Connect voltmeter V1 to TP1 and TP2 as shown in Figure 5-1.
6. Connect voltmeter V2 to TP3 and TP4 as shown in Figure 5-1.
7. Place the fan as shown in Figure 5-1 and turn it on, ensuring that the air blows directly across the evaluation module.



## 6 Configurations

### 6.1 Enable Selection (J3)

The converter can be enabled and disabled by J3. Shorting J3 discharges the soft-start capacitor and disables the TPS56121 converter. Opening J3 enables the TPS56121 converter.

**Default setting:** short to disable the converter.

## 7 Test Point Descriptions

**Table 7-1. Test Point Descriptions**

TEST POINT	LABEL	DESCRIPTION
TP1	VIN	Measurement test point for input voltage
TP2	GND	Ground test point for input voltage
TP3	VOUT	Measurement test point for output voltage
TP4	GND	Ground test point for output voltage
TP5	EN/SS	Measurement test point for enable/soft-start
TP6	PGOOD	Measurement test point for power good
TP7	CHA	Measurement test point for channel A of loop response
TP8	SGND	Ground test point for channel A of loop response
TP9	SGND	Ground test point for channel B of loop response
TP10	CHB	Measurement test point for channel B of loop response
TP11	SW	Measurement test point for switch node voltage
TP12	GND	Ground test point for switch node voltage

### 7.1 Input Voltage Monitoring (TP1 and TP2)

TPS56121EVM-601 provides two test points for measuring the input voltage applied to the module. This allows the user to measure the actual input module voltage without losses from input cables and connectors. To use TP1 and TP2, connect a voltmeter positive input terminal to TP1 and negative input terminal to TP2.

### 7.2 Output Voltage Monitoring (TP3 and TP4)

TPS56121EVM-601 provides two test points for measuring the output voltage generated by the module. To use TP3 and TP4, connect a voltmeter positive input terminal to TP3 and negative input terminal to TP4. For output ripple monitoring, please refer to the tip and barrel measurement technique in [Section 8.2](#).

### 7.3 Enable/Soft-start Monitoring (TP5)

TPS56121EVM-601 provides a test point for measuring the enable/soft-start voltage of the TPS56121 converter. This test point can be monitored to observe the start-up calibration waveform, soft-start ramp or fault time-out timing.

The enable/soft-start test point should not be actively driven from an external circuit, such as a logic output of another power supply.

### 7.4 Power Good Monitoring (TP6)

TPS56121EVM-601 provides a test points for measuring the Power Good voltage of the TPS56121 converter.

### 7.5 Loop Response Testing (TP7, TP8, TP9 and TP10)

TPS56121EVM-601 provides four test points (two signals and two grounds) for measuring the control loop frequency response. This allows the user to measure the actual module loop response without modifying the evaluation board. See [Section 8.3](#) for additional detail.

### 7.6 Switch Node Voltage Monitoring (TP11 and TP12)

TPS56121EVM-601 provides two test points for measuring the switch node. To monitor the switch node voltage, set oscilloscope per Oscilloscope For Switching Waveforms in [Section 5.1.4](#). Connect the oscilloscope probe to TP11 and the ground lead of the probe to TP12. To monitor the voltage spike on switch node, please remove the bandwidth limit on the oscilloscope and refer to the Application Report SLPA005 (Reducing Ringing Through PCB Layout Techniques) for the measurement techniques.

## 8 Test Procedures

### 8.1 Start Up/Shut Down Procedure

1. Set up the EVM as described in [Section 5.3](#) and [Figure 5-1](#).
2. Ensure LOAD is set to sink 0 A<sub>DC</sub>.
3. Ensure jumper J3 set per [Section 6.1](#).
4. Increase VIN from 0 V<sub>DC</sub> to 12 V<sub>DC</sub>. Using V1 to measure VIN voltage.
5. Open jumper J3 to enable the converter.
6. Use V2 to measure VOUT voltage, A1 to measure VIN voltage.
7. Vary LOAD from 0 A<sub>DC</sub> to 15 A<sub>DC</sub>, VOUT should remain in load regulation.
8. Vary VIN from 8 V to 14 V, VOUT should remain in line regulation.
9. Short jumper J3 to disable the converter.
10. Decrease VIN to 0 V.
11. Decrease LOAD to 0 A.

### 8.2 Output Ripple Voltage Measurement Procedure

1. Follow [Section 8.1](#) to set VIN and LOAD to desired operating condition.
2. Set oscilloscope for Output Voltage Ripple Measurement in [Section 5.1.4](#).
3. Connect oscilloscope probe with exposed metal barrel to TP3 and TP4 per [Figure 8-1](#). Using a leaded ground connection may induce additional noise due to the large ground loop.
4. Follow [Section 8.1](#) to power down.

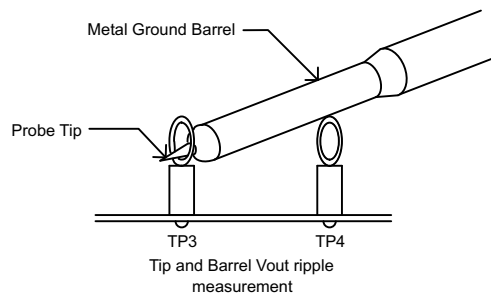

**Figure 8-1. Tip and Barrel Output Voltage Ripple Measurement**

### 8.3 Control Loop Gain and Phase Measurement Procedure

1. Follow Section 8.1 to set VIN and LOAD to desired operating condition.
2. Connect isolation transformer to test points TP7 and TP10 as shown in Figure 8-2.
3. Connect input signal amplitude measurement probe (Channel A) to TP7 as shown in Figure 8-2.
4. Connect output signal amplitude measurement probe (Channel B) to TP10 as shown in Figure 8-2.
5. Connect ground lead of Channel A and Channel B to TP8 and TP9 as shown in Figure 8-2, respectively.
6. Inject 10 mV or less signal through the isolation transformer.
7. Sweep the frequency from 500 Hz to 500 kHz with 10-Hz or lower post filter.

$$20 \times \log \left( \frac{\text{Channel B}}{\text{Channel A}} \right)$$

8. Control loop gain can be measured by
9. Control loop phase can be measured by the phase difference between Channel A and Channel B.
10. Follow Section 8.1 to power down.

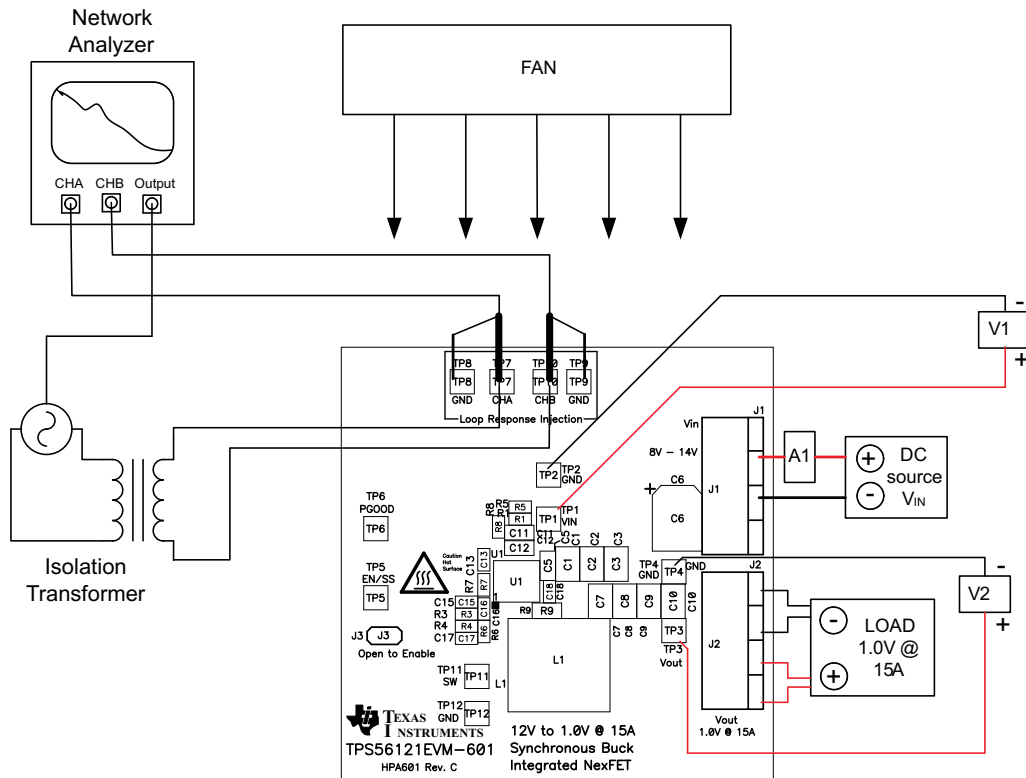

Figure 8-2. Control Loop Measurement Setup

### 8.4 Equipment Shutdown

1. Shut down VIN.
2. Shut down LOAD.
3. Shut down fan.
4. Shut down oscilloscope.

## 9 Performance Data and Typical Characteristic Curves

Figure 9-1 through Figure 9-12 present typical performance curves for the TPS56121EVM-601. Since actual performance data can be affected by measurement techniques and environmental variables, these curves are presented for reference and may differ from actual field measurements.

### 9.1 Efficiency

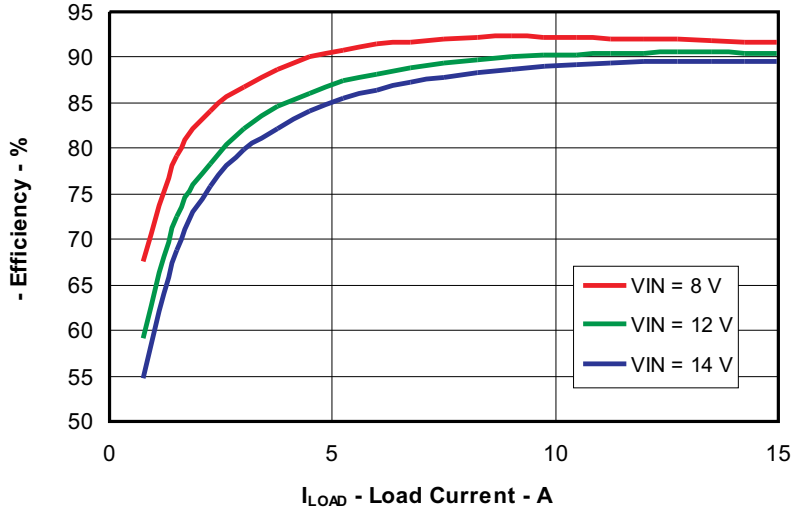

Figure 9-1. Efficiency

### 9.2 Load Regulation

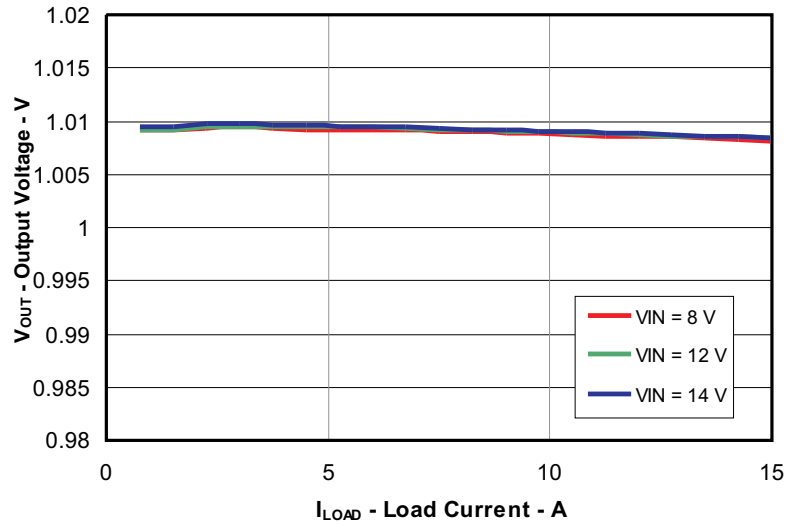

Figure 9-2. Load Regulation

### 9.3 Line Regulation

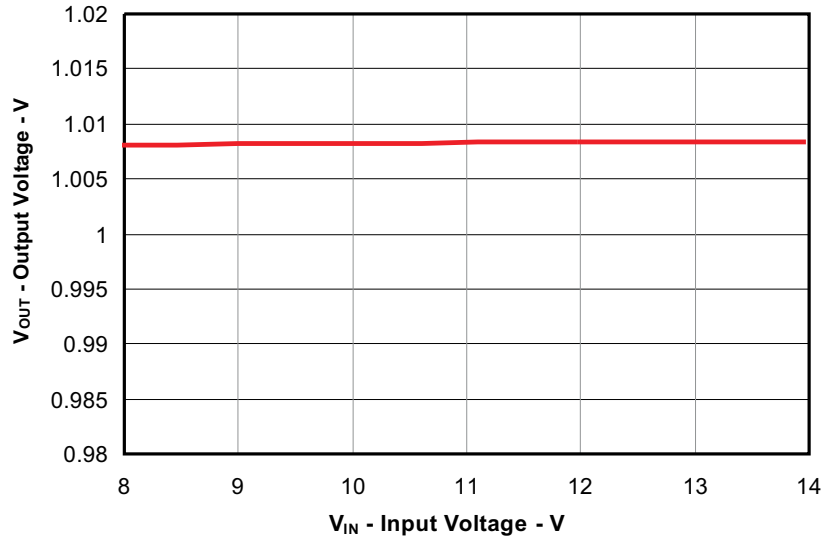

Figure 9-3. Line Regulation (V<sub>IN</sub> = 8 V to 14 V, V<sub>OUT</sub> = 1.0 V, I<sub>OUT</sub> = 15 A)

### 9.4 Output Voltage Ripple

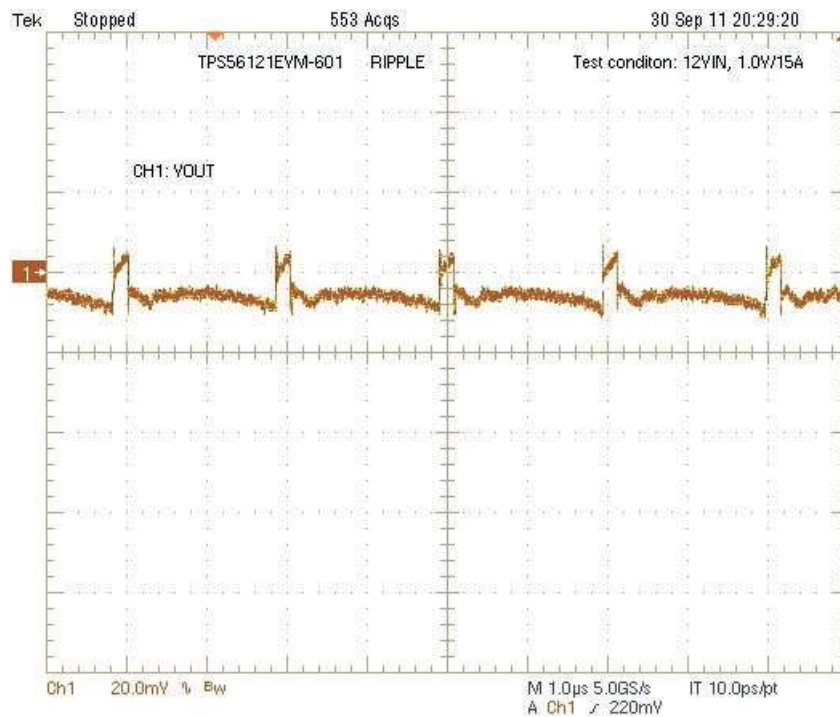

Figure 9-4. Output Voltage Ripple (V<sub>IN</sub> = 12 V, V<sub>OUT</sub> = 1.0 V, I<sub>OUT</sub> = 15 A)

## 9.5 Switch Node

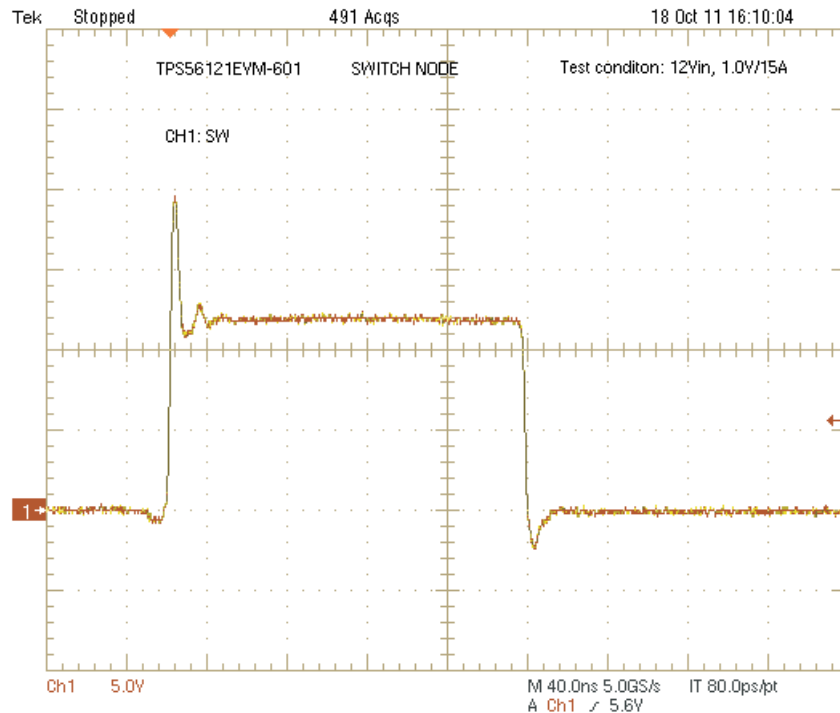

Figure 9-5. Switch Node Waveform Measured at Pins Using Tip and Barrel Measurement Technique (VIN = 12 V, VOUT = 1.0 V, IOU = 15 A)

## 9.6 Load Transient

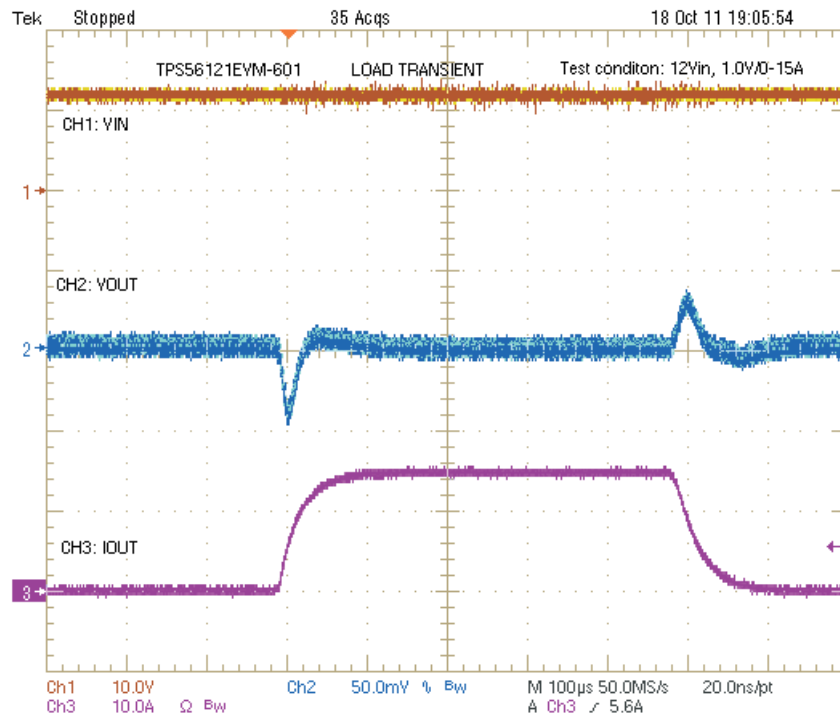

Figure 9-6. Load Transient (VIN = 12 V, VOUT = 1.0 V, IOU = 0 A to 15 A)

### 9.7 Start Up

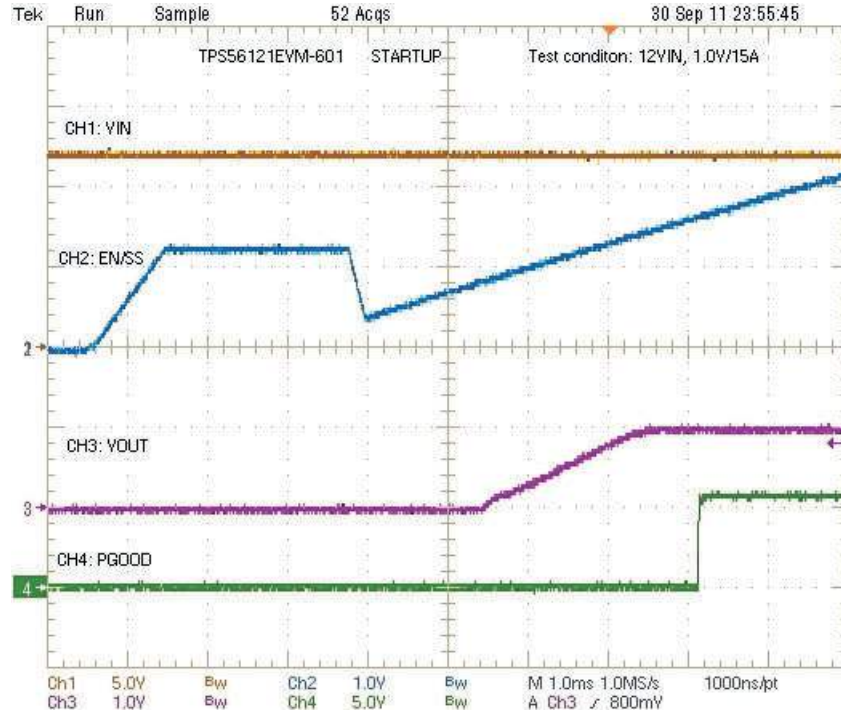

Figure 9-7. Start-Up Waveform (VIN = 12 V, VOUT = 1.0 V, IOUT = 15 A)

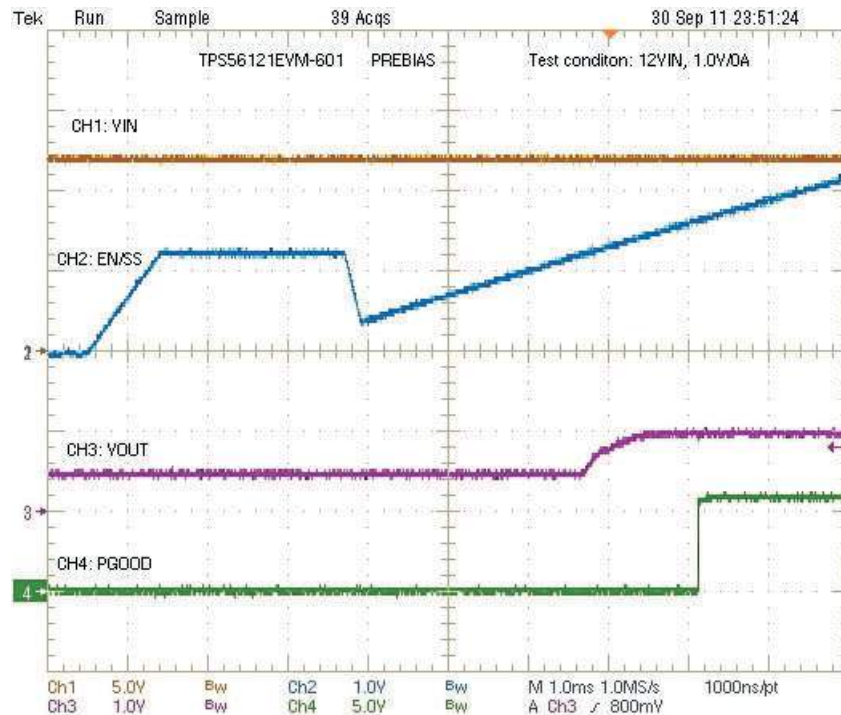

Figure 9-8. Pre-Biased Start-Up Waveform (VIN = 12 V, VOUT = 1.0 V, IOUT = 0 A)



### 9.8 Power Off

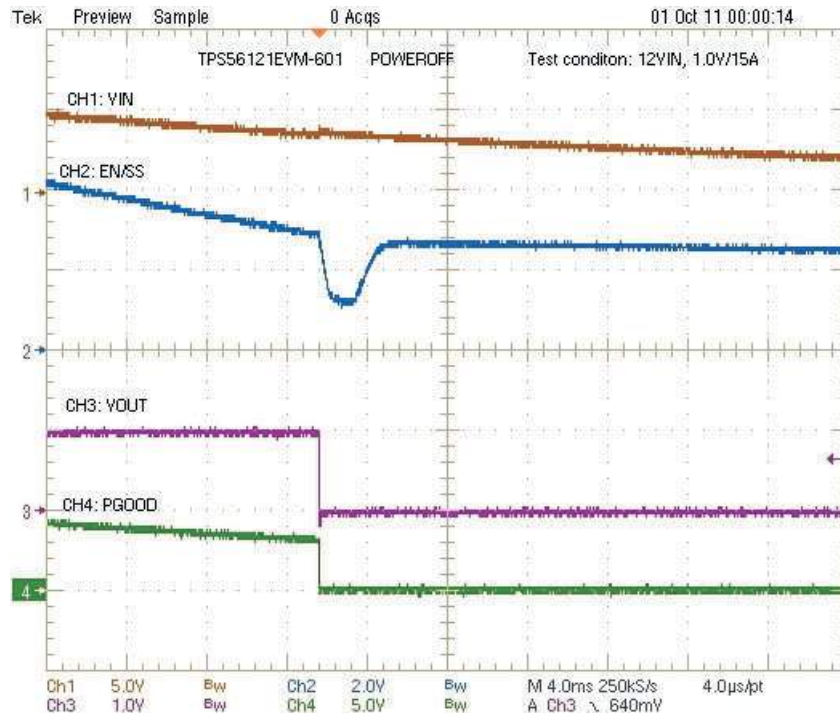

Figure 9-9. Power-Off Waveform (VIN = 12 V, VOUT = 1.0 V, IOUT = 15 A)

### 9.9 Over-Current Protection

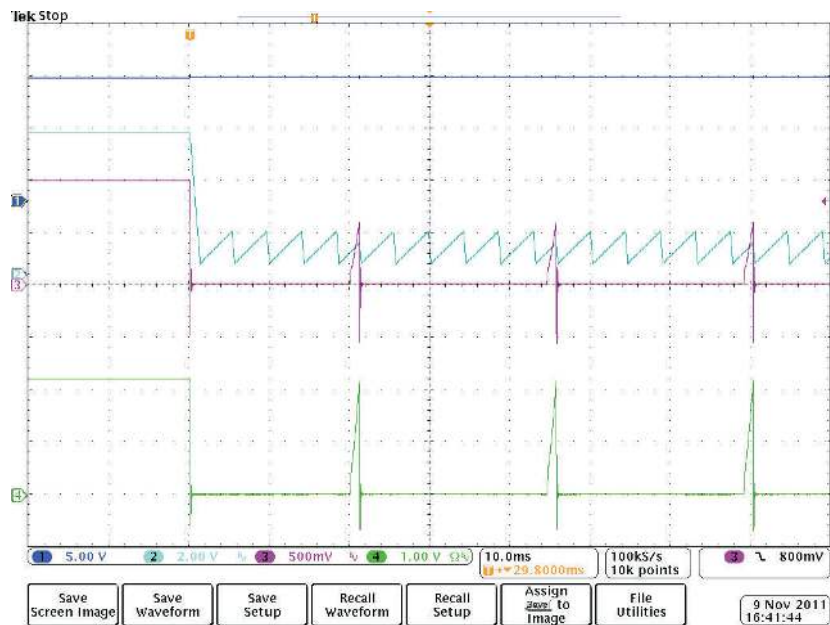

Figure 9-10. Over-Current Protection Waveform (Ch1: VIN, Ch2: EN/SS, Ch3: VOUT, Ch4: IOUT (10 A/div), VIN = 12 V, VOUT = 1.0 V, IOUT = 23 A)

### 9.10 Control Loop Bode Plot

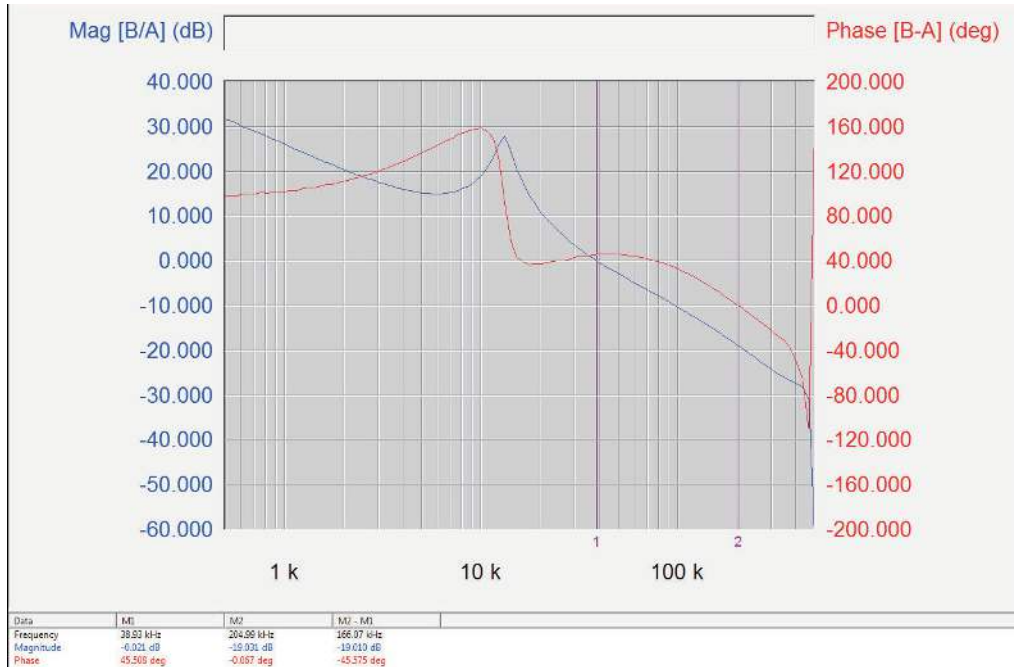

Figure 9-11. Loop Gain ( $V_{IN} = 12\text{ V}$ ,  $V_{OUT} = 1.0\text{ V}$ ,  $I_{OUT} = 15\text{ A}$ , Bandwidth: 39 kHz, Phase Margin: 46°)

### 9.11 Thermal Image

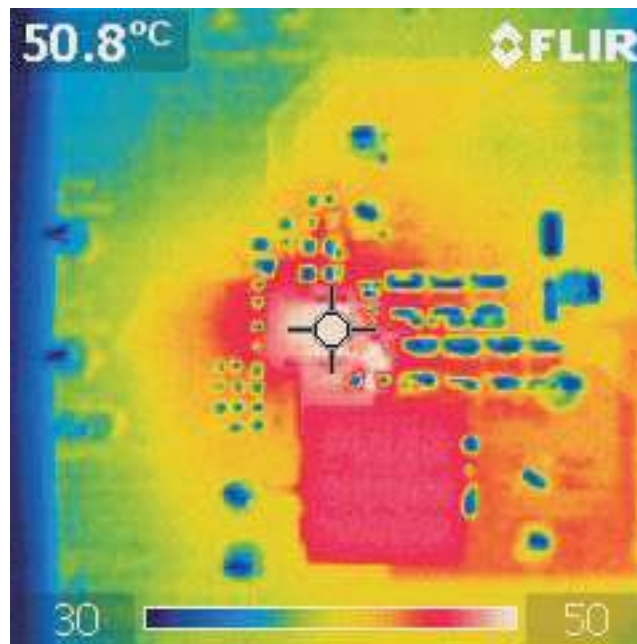

Figure 9-12. Thermal Image ( $V_{IN} = 14\text{ V}$ ,  $V_{OUT} = 1.0\text{ V}$ ,  $I_{OUT} = 15\text{ A}$ , without airflow)

## 10 EVM Assembly Drawings and PCB Layout

The following figures (Figure 10-1 through Figure 10-6) show the design of the TPS56121EVM-601 printed circuit board. The EVM has been designed using a 4-layer, 2-oz copper-clad circuit board 2.5" x 2.5" with components on both sides of the PCB to allow the user to view, probe and evaluate the TPS56121 high current converter with integrated FETs in a small form factor, high-current application.

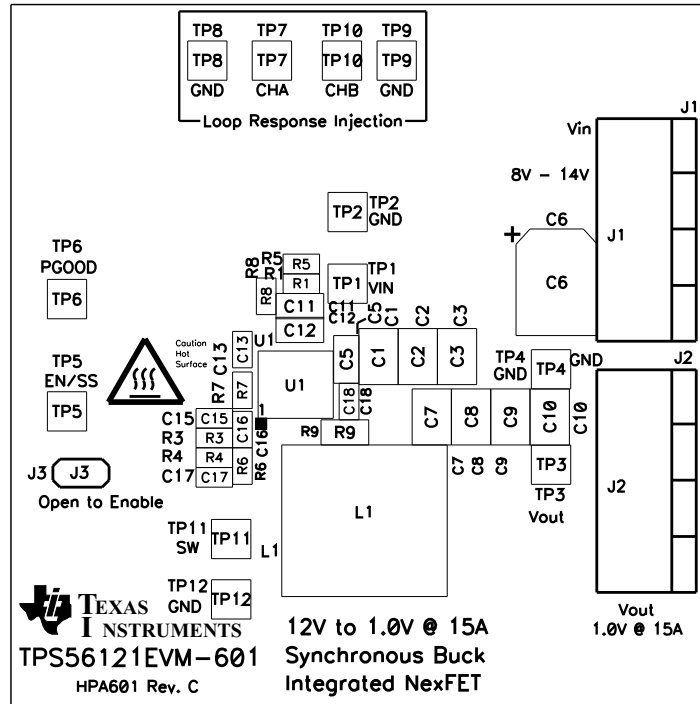

Figure 10-1. TPS56121EVM-601 Top Assembly Drawing (top view)

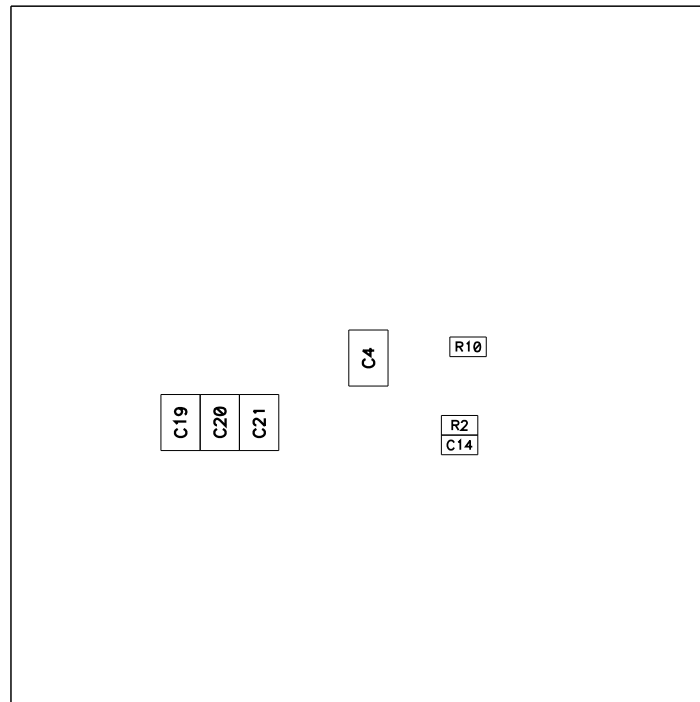
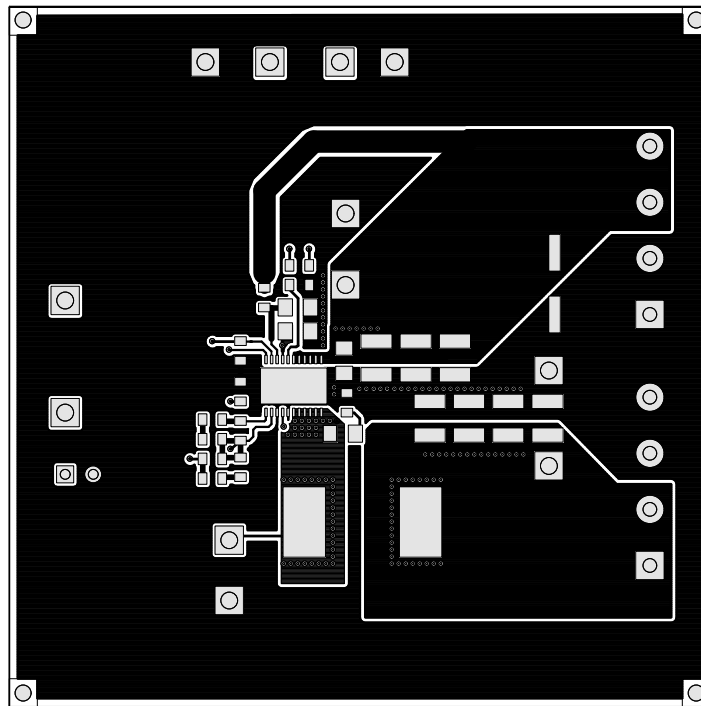
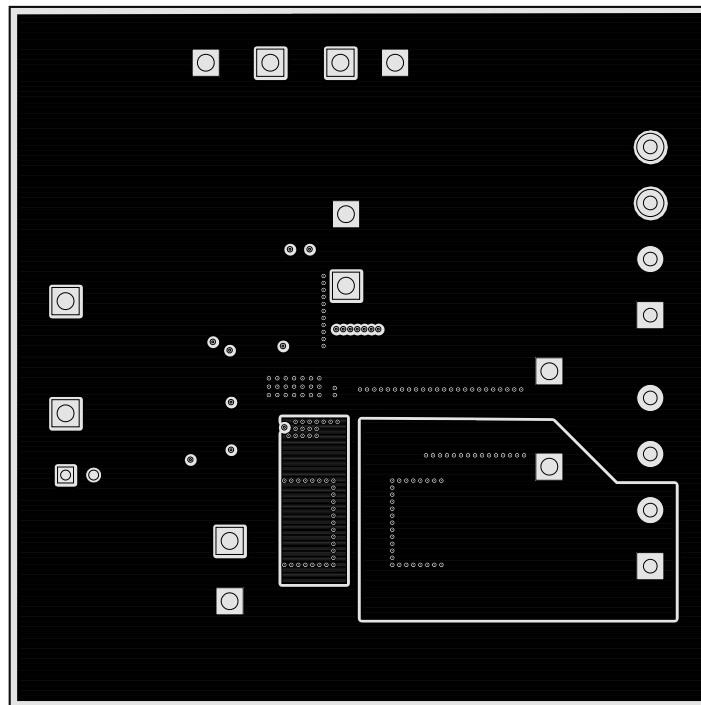

Figure 10-2. TPS56121EVM-601 Bottom Assembly Drawing (bottom view)



**Figure 10-3. TPS56121EVM-601 Top Copper (top view)**



**Figure 10-4. TPS56121EVM-601 Internal 1 (top view)**

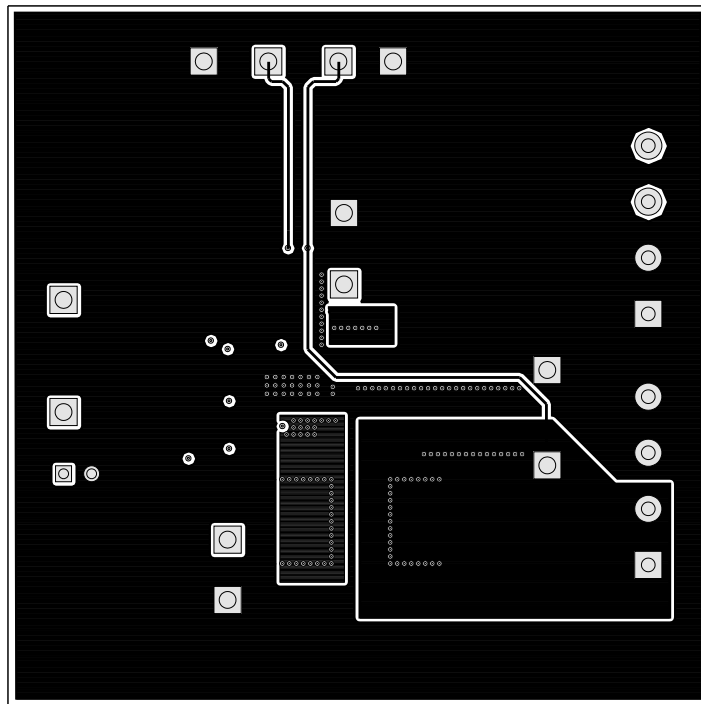

Figure 10-5. TPS56121EVM-601 Internal 2 (top view)

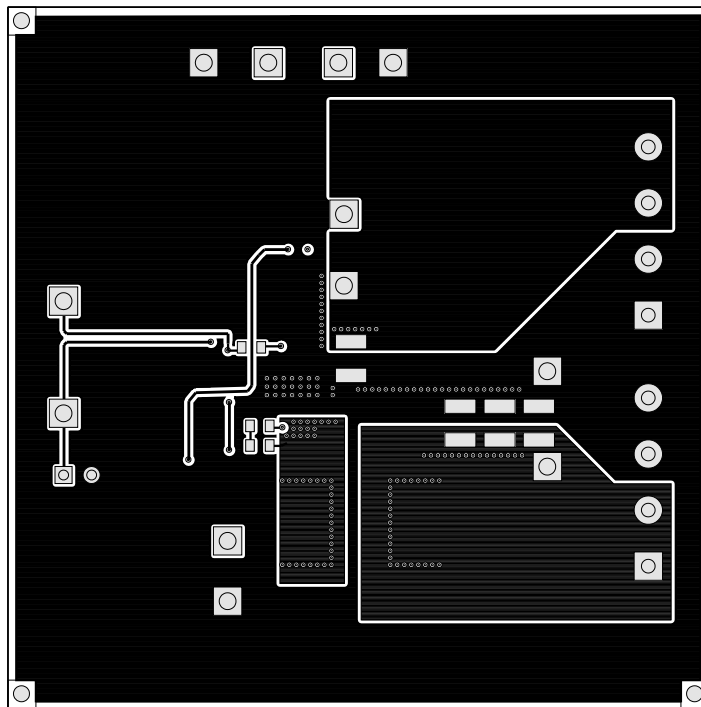

Figure 10-6. TPS56121EVM-601 Bottom Copper (top view)

## 11 List of Materials

**Table 11-1. TPS56121EVM-601 List of Materials**

QTY	REF DES	DESCRIPTION	PART NUMBER	MFR
4	C1, C2, C3, C4	Capacitor, ceramic, 25 V, X5R, 20%, 22 $\mu$ F, 1210	Std	Std
2	C5, C11	Capacitor, ceramic, 25 V, X5R, 20%, 1.0 $\mu$ F, 0805	Std	Std
0	C6	Capacitor, aluminum, 16 V <sub>DC</sub> , $\pm$ 20%, 100 $\mu$ F, code D8	EEEF1C101AP	Panasonic
5	C7, C8, C9, C10, C19	Capacitor, ceramic, 6.3 V, X5R, 20%, 100 $\mu$ F, 1210	Std	Std
1	C12	Capacitor, ceramic, 10 V, X5R, 20%, 4.7 $\mu$ F, 0805	Std	Std
1	C13	Capacitor, ceramic, 16 V, X7R, 20%, 33 nF, 0603	Std	Std
1	C14	Capacitor, ceramic, 50 V, X7R, 20%, 100 nF, 0603	Std	Std
1	C15	Capacitor, ceramic, 50 V, X7R, 10%, 2200 pF, 0603	Std	Std
1	C16	Capacitor, ceramic, 50 V, C0G, 5%, 100 pF, 0603	Std	Std
1	C17	Capacitor, ceramic, 50 V, C0G, 5%, 680 pF, 0603	Std	Std
1	C18	Capacitor, ceramic, 50 V, X7R, 20%, 1000 pF, 0603	Std	Std
0	C20, C21	Capacitor, ceramic, 6.3 V, X5R, 20%, 100 $\mu$ F, 1210	Std	Std
2	J1, J2	Terminal block, 4 pin, 15 A, 5.1 mm, 0.80 inch x 0.35 inch	ED120/4DS	OST
1	J3	Header, male 2 pin, 100-mil spacing, 0.100 inch x 2 inch	PEC02SAAN	Sullins
1	L1	Inductor, 440 nH, 30 A, 0.32 m $\Omega$ , 440 nH, 0.530 inch x 0.510 inch	PA0513.441NLT	Pulse
1	R1	Resistor, chip, 1/16 W, 1%, 1.78 k $\Omega$ , 0603	Std	Std
1	R2	Resistor, chip, 1/16 W, 1%, 5.10 $\Omega$ , 0603	Std	Std
1	R3	Resistor, chip, 1/16 W, 1%, 7.87 k $\Omega$ , 0603	Std	Std
1	R4	Resistor, chip, 1/16 W, 1%, 20.5 k $\Omega$ , 0603	Std	Std
1	R5	Resistor, chip, 1/16 W, 1%, 49.9 $\Omega$ , 0603	Std	Std
1	R6	Resistor, chip, 1/16 W, 1%, 1.00 k $\Omega$ , 0603	Std	Std
1	R7	Resistor, chip, 1/16 W, 1%, 30.1 k $\Omega$ , 0603	Std	Std
1	R8	Resistor, chip, 1/16 W, 1%, 0 k $\Omega$ , 0603	Std	Std
1	R9	Resistor, chip, 1/8 W, 1%, 1.00 $\Omega$ , 0805	Std	Std
1	R10	Resistor, chip, 1/16 W, 1%, 100 k $\Omega$ , 0603	Std	Std
3	TP1, TP3, TP11	Test point, red, thru hole, 0.125 inch x 0.125 inch	5010	Keystone
5	TP2, TP4, TP8, TP9, TP12	Test point, black, thru hole, 0.125 inch x 0.125 inch	5011	Keystone
2	TP5, TP6	Test point, yellow, thru hole, 0.125 x 0.125 inch	5014	Keystone
2	TP7, TP10	Test point, white, thru hole, 0.125 x 0.125 inch	5012	Keystone
1	U1	4.5-V to 14-V Input 15-A Synchronous Buck Converter, QFN-22 6 mm x 5 mm	TPS56121DQP	TI
1	--	PCB, 2.5 inch x 2.5 inch x 0.062 inch	HPA601	Any
1	--	Shunt, 100 mil, black, 0.100	929950-00	3M

## 12 Revision History

NOTE: Page numbers for previous revisions may differ from page numbers in the current version.

### Changes from Revision B (March 2011) to Revision C (August 2021)

Page

- Updated user's guide title..... 3
- Updated the numbering format for tables, figures, and cross-references throughout the document. ....3

## IMPORTANT NOTICE AND DISCLAIMER

TI PROVIDES TECHNICAL AND RELIABILITY DATA (INCLUDING DATA SHEETS), DESIGN RESOURCES (INCLUDING REFERENCE DESIGNS), APPLICATION OR OTHER DESIGN ADVICE, WEB TOOLS, SAFETY INFORMATION, AND OTHER RESOURCES "AS IS" AND WITH ALL FAULTS, AND DISCLAIMS ALL WARRANTIES, EXPRESS AND IMPLIED, INCLUDING WITHOUT LIMITATION ANY IMPLIED WARRANTIES OF MERCHANTABILITY, FITNESS FOR A PARTICULAR PURPOSE OR NON-INFRINGEMENT OF THIRD PARTY INTELLECTUAL PROPERTY RIGHTS.

These resources are intended for skilled developers designing with TI products. You are solely responsible for (1) selecting the appropriate TI products for your application, (2) designing, validating and testing your application, and (3) ensuring your application meets applicable standards, and any other safety, security, regulatory or other requirements.

These resources are subject to change without notice. TI grants you permission to use these resources only for development of an application that uses the TI products described in the resource. Other reproduction and display of these resources is prohibited. No license is granted to any other TI intellectual property right or to any third party intellectual property right. TI disclaims responsibility for, and you will fully indemnify TI and its representatives against, any claims, damages, costs, losses, and liabilities arising out of your use of these resources.

TI's products are provided subject to [TI's Terms of Sale](#) or other applicable terms available either on [ti.com](http://ti.com) or provided in conjunction with such TI products. TI's provision of these resources does not expand or otherwise alter TI's applicable warranties or warranty disclaimers for TI products.

TI objects to and rejects any additional or different terms you may have proposed.

Mailing Address: Texas Instruments, Post Office Box 655303, Dallas, Texas 75265  
Copyright © 2022, Texas Instruments Incorporated