

7 6 5 4 3 2 1

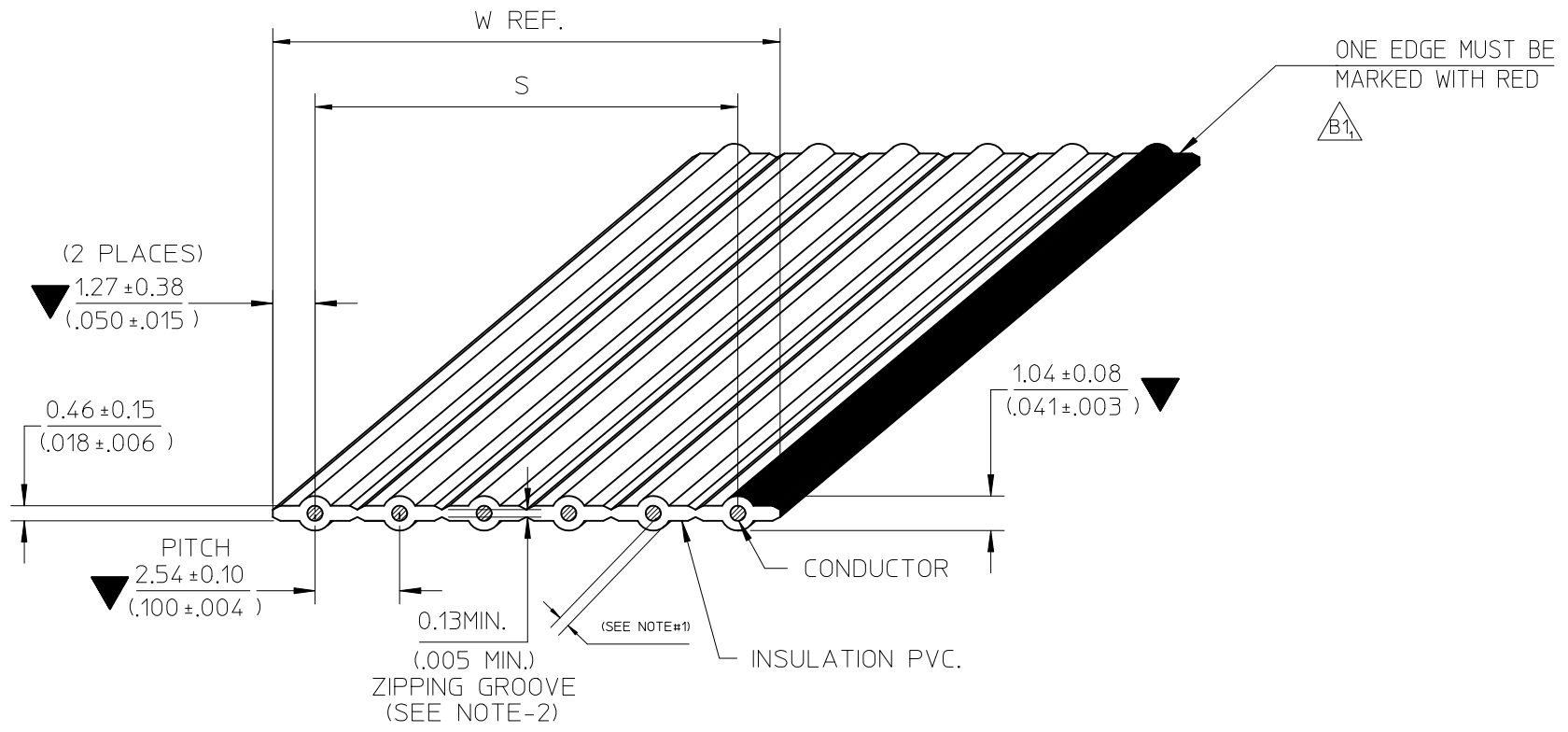

- NOTE :
1. THE CABLE SHALL HAVE A MINIMUM OF 0.178mm. (.007") THICKNESS INSULATION AT ANY POINT
  2. RIP TEST:
    - THE 0.13mm. (.005") ZIPPING GROOVE SHALL BE CAPABLE OF BEING RIPPED BY HAND WITHIN THE RECESS, WITHOUT EXPOSING THE ADJACENT CONDUCTORS
  3. RoHS AND LEAD FREE COMPLIANT
  4. SPECIAL REQUIREMENT: N/A

PRODUCT APPLICATION	
<input checked="" type="checkbox"/>	GENERAL USE
<input type="checkbox"/>	AUTOMOTIVE
<input type="checkbox"/>	MEDICAL DEVICE

SEE CHANGE DETAIL EC NO: THL2011-0054 DRWN: CPANSAKHOM 2010/10/05 CHKD: PREECHAI 2011/01/25 APPR: SVIRAT JAPOL 2011/03/31	QUALITY SYMBOLS	▼ = 3 ◻ = 0
	DESCRIPTION	
	REV	
	B1	

GENERAL TOLERANCES (UNLESS SPECIFIED)	
mm	INCH
4 PLACES ± ---	± ---
3 PLACES ± ---	± ---
2 PLACES ± ---	± ---
1 PLACE ± ---	± ---
ANGULAR ± ---°	
DRAFT WHERE APPLICABLE MUST REMAIN WITHIN DIMENSIONS	

DIMENSION STYLE	
MM/IN	
DRAWN BY	DATE
CPANSAKHOM	2006/07/18
CHECKED BY	DATE
PMEECHAI	2006/07/18
APPROVED BY	DATE
SVIRAT JAPOL	2006/07/18
MATERIAL NO.	
SEE CHART	

SCALE	DESIGN UNITS	THIRD ANGLE PROJECTION
NTS	INCH	
TITLE		
FCB ROUND CONDUCTOR 2.54MM(.100)CENTER PVC. 26AWG SOLID TINNED		
MOLEX INCORPORATED		
DOCUMENT NO.	SHEET NO.	
SD-7234-001	1 OF 3	
THIS DRAWING CONTAINS INFORMATION THAT IS PROPRIETARY TO MOLEX INCORPORATED AND SHOULD NOT BE USED WITHOUT WRITTEN PERMISSION		

B1	E-10-0371	B1 : REMOVE REELS MFG. IN NOG.	2011/01/25
B	E-07-0748	B2 : ADD NON-OPERATING TEMP. B3 : ADD SOLDERING CONDITION	2007/09/27
A	N/A	NEW RELEASE	2006/07/18
REV. HISTORY	EC NO.	DETAIL	DATE

6 5 4 3 2 1

SPECIFICATIONS

PHYSICAL

CONDUCTOR SPACING ----- 2.54(.100")  $\bar{C}$  TO  $\bar{C}$   
 WIRE GAUGE ----- 26 AWG(1/26) SOLID TINNED  
 INSULATION ----- P.V.C GRAY (LEAD FREE)

AGENCY

U.L. STYLE NO. ----- 2651  
 TEMPERATURE RATING ----- -20°C TO 105°C  
 VOLTAGE RATING ----- 300V.MAX.  
 FLAMMABILITY RATING ----- VW-1

ELECTRICAL

CONDUCTOR RESISTANCE (D.C.) ----- 45 m OHMS/FT. MAX.  
 CHARACTERISTIC IMPEDANCE ----- 150 OHMS NOM. (GS)  
 ----- 128 OHMS NOM. (GSG)  
 CAPACITANCE ----- 5.2 pF/FT. NOM. (GS)  
 ----- 9.24 pF/FT. NOM. (GSG)  
 PROPAGATION DELAY ----- 1.4 ns/FT. NOM.  
 INSULATION RESISTANCE ----- 10 M OHMS (10FT. SAMPLE)  
 DIELECTRIC WITHSTAND VOLTAGE ----- 2000 VRMS/MINUTE

GENERAL

NON-OPERATING TEMPERATURE ----- -20°C TO 105°C  
 FAULTS AND/OR SPLICES ----- 1/REEL MAX. 100<sup>+3</sup><sub>0</sub> FT. (30.48<sup>+0.914</sup><sub>0</sub> M.)/REEL  
 ----- 20FT. (6.096M.) MIN. LENGTH

SOLDERING CONDITION

SOLDER TEMPERATURE ----- 260°C. MAX.  
 SOLDERING TIME ----- 3 SECOND, MAX.  
 INSULATION SHRINK ----- 2MM. NOM

SEE CHANGE DETAIL EC NO: THL2011-0054 DRWN: CPANSAKHOM 2010/10/05 CHKD: PMEECHAI 2011/01/25 APPR: SVIRAT JAPOL 2011/03/31	DESCRIPTION REV	QUALITY SYMBOLS	GENERAL TOLERANCES (UNLESS SPECIFIED)	DIMENSION STYLE MM/IN	SCALE NTS	DESIGN UNITS INCH	THIRD ANGLE PROJECTION
		▼ = ▽ =	mm      INCH 4 PLACES ± --- ± --- 3 PLACES ± --- ± --- 2 PLACES ± --- ± --- 1 PLACE ± --- ± --- ANGULAR ± ---°	DRAWN BY      DATE CPANSAKHOM    2006/07/18 CHECKED BY      DATE PMEECHAI        2006/07/18 APPROVED BY      DATE SVIRAT JAPOL    2006/07/18 MATERIAL NO.	TITLE FCB ROUND CONDUCTOR 2.54MM(.100)CENTER PVC. 26AWG SOLID TINNED MOLEX MOLEX INCORPORATED DOCUMENT NO.	SHEET NO. 2 OF 3	
		DRAFT WHERE APPLICABLE MUST REMAIN WITHIN DIMENSIONS	SEE CHART	SD-7234-001			
		SIZE A 4	THIS DRAWING CONTAINS INFORMATION THAT IS PROPRIETARY TO MOLEX INCORPORATED AND SHOULD NOT BE USED WITHOUT WRITTEN PERMISSION				
		B1					

7

6

5

4

3

2

1

CHART A					SHIPPED ON	
DIMENSIONS MM. (INCHES)					100 FT. REELS	
ENG. NO.	NO.OF COND.	DIMENSION S		DIM. W (REF)	ENGINEERING NO.	ORDER NO.
7234-02	2	2.54±0.10	(.100±.004)	5.08 (.200)	7234-02-100B	82-26-5702
7234-03	3	5.08±0.20	(.200±.008)	7.62 (.300)	▲ -03- ▲	▲ 03
7234-04	4	7.62±0.30	(.300±.012)	10.16 (.400)	▲ -04- ▲	▲ 04
7234-05	5	10.16±0.33	(.400±.013)	12.70 (.500)	▲ -05- ▲	▲ 05
7234-06	6	12.70±0.33	(.500±.013)	15.24 (.600)	▲ -06- ▲	▲ 06
7234-07	7	15.24±0.33	(.600±.013)	17.78 (.700)	▲ -07- ▲	▲ 07
7234-08	8	17.78±0.33	(.700±.013)	20.32 (.800)	▲ -08- ▲	▲ 08
7234-09	9	20.32±0.33	(.800±.013)	22.86 (.900)	▲ -09- ▲	▲ 09
7234-10	10	22.86±0.33	(.900±.013)	25.40 (1.000)	▲ -10- ▲	▲ 10
7234-11	11	25.40±0.33	(1.000±.013)	27.94 (1.100)	▲ -11- ▲	▲ 11
7234-12	12	27.94±0.33	(1.100±.013)	30.48 (1.200)	▲ -12- ▲	▲ 12
7234-13	13	30.48±0.33	(1.200±.013)	33.02 (1.300)	▲ -13- ▲	▲ 13
7234-14	14	33.02±0.33	(1.300±.013)	35.56 (1.400)	▲ -14- ▲	▲ 14
7234-15	15	35.56±0.33	(1.400±.013)	38.10 (1.500)	▲ -15- ▲	▲ 15
7234-16	16	38.10±0.33	(1.500±.013)	40.64 (1.600)	▲ -16- ▲	▲ 16
7234-17	17	40.64±0.33	(1.600±.013)	43.18 (1.700)	▲ -17- ▲	▲ 17
7234-18	18	43.18±0.33	(1.700±.013)	45.72 (1.800)	▲ -18- ▲	▲ 18
7234-19	19	45.72±0.33	(1.800±.013)	48.26 (1.900)	▲ -19- ▲	▲ 19
7234-20	20	48.26±0.33	(1.900±.013)	50.80 (2.000)	▼ -20- ▼	▼ 20

ENGINEERING NO.

7234-XX-XXXX  
A B C D

A : CABLE 2.54mm. (.100") CENTERS 26 AWG SOLID TINNED

B : CONDUCTOR SIZE ( AVAILABILITY 2 THROUGH 20 )

C : CABLE LENGTH 100FT. (30.48M.)

D : A = INCHES

B = FEET

SEE CHANGE DETAIL EC NO: THL2011-0054 DRAWN: CPANSAKHOM 2010/10/05 CHKD: PREECHAI 2011/01/25 APPR: SVIRAT JAPOL 2011/03/31	QUALITY SYMBOLS ▼ = ▽ =	DESCRIPTION REV	GENERAL TOLERANCES (UNLESS SPECIFIED)		DIMENSION STYLE MM/IN	SCALE NTS	DESIGN UNITS INCH	THIRD ANGLE PROJECTION
				mm	INCH	DRAWN BY CPANSAKHOM	DATE 2006/07/18	TITLE FCB ROUND CONDUCTOR 2.54MM(.100)CENTER PVC. 26AWG SOLID TINNED  MOLEX INCORPORATED
			4 PLACES	± ---	± ---	CHECKED BY PREECHAI	DATE 2006/07/18	
			3 PLACES	± ---	± ---	APPROVED BY SVIRAT JAPOL	DATE 2006/07/18	
			2 PLACES	± ---	± ---	MATERIAL NO.	DOCUMENT NO.	
1 PLACE	± ---	± ---	SEE CHART					
			ANGULAR ± ---°					
			DRAFT WHERE APPLICABLE MUST REMAIN WITHIN DIMENSIONS					
					SIZE A 4	THIS DRAWING CONTAINS INFORMATION THAT IS PROPRIETARY TO MOLEX INCORPORATED AND SHOULD NOT BE USED WITHOUT WRITTEN PERMISSION		

6

5

4

3

2

1

A