

MAXIM

270Mbps SFP LED Driver

MAX3967

General Description

The MAX3967 is a programmable LED driver for fiber optic transmitters operating at data rates up to 270Mbps. The circuit contains a high-speed current driver with programmable temperature coefficient (tempco), adjustments for LED prebias voltage, and a disable feature. The circuit accepts PECL data inputs, and operates from a single +2.97V to +5.5V power supply.

The SFP LED driver can switch up to 100mA into typical high-speed light-emitting diodes. As temperature increases, the device's modulation current increases with a tempco that is programmable from 2500ppm/°C to 12,000ppm/°C. The modulation current is programmed with a single external resistor.

The MAX3967's LED prebias voltage is programmable from 400mV to 925mV. The prebias circuit produces peaking current, which improves the LED switching speed.

Complementary current outputs help to maintain a constant supply current, reducing EMI and supply noise generated by the transmitter module. The MAX3967 is available in die form, or in a 4mm x 4mm, 24-pin thin QFN package.

Applications

Multimode LED Transmitters
Fast Ethernet/FDDI
155Mbps LAN ATM Transceivers
ESCON Receivers
SFP Transceivers

Typical Operating Circuits appear at end of data sheet.

Features

- ◆ TX_DISABLE for SFP Compatibility
- ◆ Single +2.97V to +5.5V Power Supply
- ◆ Adjustable Temperature Compensation
- ◆ Adjustable Modulation Current
- ◆ Complementary Output Reduces Supply Noise
- ◆ Programmable LED Prebias Voltage
- ◆ Available in 24-Pin QFN or Die

Ordering Information

PART	TEMP RANGE	PIN-PACKAGE
MAX3967ETG	-40°C to +85°C	24 Thin QFN
MAX3967E/D	-40°C to +85°C	Dice*

*Dice are tested and guaranteed only at $T_A = +25^\circ\text{C}$.

Pin Configuration

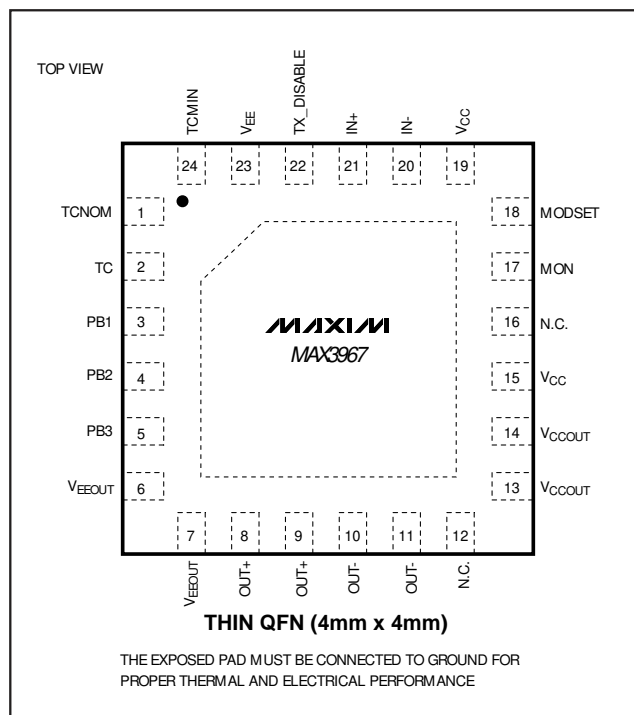

270Mbps SFP LED Driver

ABSOLUTE MAXIMUM RATINGS

Supply Voltage at V _{CC} , V _{CCOUT} (V _{EE} , V _{EEOUT} = 0V)	-0.5V to +7V	Continuous Power Dissipation (T _A = +85°C) 24-Lead Thin QFN (derate 20.8mW/C° above +85°C).....	1354mW
Current into OUT+, OUT-	-40mA to +160mA	Operating Junction Temperature	-40°C to +150°C
Differential Output Voltage (OUT+ to OUT-)	-3.3V to +3.3V	Die Attach Temperature.....	+400°C
Voltage at PB1, PB2, PB3, IN+, IN-, OUT+, OUT-, TX_DISABLE.....	-0.5V to (V _{CC} + 0.5V)	Storage Temperature Range	-50°C to +150°C
Voltage at TCMIN, TCNOM, TC, MODSET, MON	-0.5V to +2V	Lead Temperature (soldering, 10s)	+300°C

Stresses beyond those listed under "Absolute Maximum Ratings" may cause permanent damage to the device. These are stress ratings only, and functional operation of the device at these or any other conditions beyond those indicated in the operational sections of the specifications is not implied. Exposure to absolute maximum rating conditions for extended periods may affect device reliability.

DC ELECTRICAL CHARACTERISTICS

(Load as specified in Figure 1; V_{CC} = +2.97V to +5.5V (at the V_{CC} pins); V_{EE}, V_{EEOUT} = 0V; T_A = -40°C to +85°C, unless otherwise noted. Temperature coefficients are referenced to T_A = +25°C. Typical values are at V_{CC} = +3.3V, T_A = +25°C, unless otherwise noted. Dice are tested at T_A = +25°C only.)

PARAMETER	SYMBOL	CONDITIONS	MIN	TYP	MAX	UNITS
Data Input High Voltage		Referenced to V _{CC} , DC-coupled input	-1.165		-0.880	V
Data Input Low Voltage		Referenced to V _{CC} , DC-coupled input	-1.810		-1.475	V
Supply Current	I _{CC}	(Note 1)		30	39	mA
Input Current at IN+ or IN-			-50		+50	μA
Modulation Current	R _{MODSET} = 698Ω (Note 2)	T _A = -40°C		110		mA
		T _A = +25°C		124		
		T _A = +85°C		139		
	R _{MODSET} = 3.0kΩ (Note 3)	T _A = -40°C		14		
		T _A = +25°C		18		
		T _A = +85°C		22		
(Note 3)		66.0	75	84.5		
Prebias Voltage		PB1, PB2, PB3 = (open, open, open)	0.368	0.400	0.451	V
		PB1, PB2, PB3 = (V _{EE} , V _{EE} , open)	0.575	0.625	0.696	
		PB1, PB2, PB3 = (V _{EE} , V _{EE} , V _{EE})	0.848	0.925	1.026	
Temperature Coefficient of Modulation Current		Maximum tempco (TC open)		12,000		ppm/°C
		Nominal tempco (TC shorted to TCNOM)		3600		
		Minimum tempco (TC shorted to TCMIN)		2500		
Prebias Resistor	R _{PREBIAS}		66	78	90	Ω
TX_DISABLE Resistance		Resistance to V _{EE} (Note 4)	50	65	100	kΩ
TX_DISABLE High	V _{IH}		2.0			V
TX_DISABLE Low	V _{IL}				0.8	V
Monitor Gain		I _{MON} / I _{MODSET} , V _{MON} < 1.1V, R _{MODSET} = 1kΩ, TC = TCMIN	0.92	1	1.08	A/A

Note 1: R_{MODSET} = 1kΩ. Excludes I_{OUT+} and I_{OUT-}, TX_DISABLE high or low.

Note 2: TC connected to TCMIN.

Note 3: V_{CC} = +3.3V, V_{LED} = 1.55V, prebias voltage programmed at 0.625V (nominal), T_A = +25°C. R_{MODSET} = 1kΩ, (programs approximately 80mA), TC connected to TCNOM.

Note 4: The TX_DISABLE pin is internally pulled low. The driver is enabled when TX_DISABLE is left open.

270Mbps SFP LED Driver

MAX3967

AC ELECTRICAL CHARACTERISTICS

(Load as specified in Figure 1, unless otherwise noted. $V_{CC} = +2.97V$ to $+5.5V$ (at the V_{CC} pins), $R_{MODSET} = 1k\Omega$, $T_A = -40^\circ C$ to $+85^\circ C$. Input data edge speed = 1ns (typ), PB1 = PB2 = V_{EE} , PB3 = open. Typical values are at $V_{CC} = +3.3V$, TC connected to TCNOM, $T_A = +25^\circ C$.) (Note 5)

PARAMETER	SYMBOL	CONDITIONS	MIN	TYP	MAX	UNITS
Data Input Range		Differential input	500		2400	mV _{P-P}
Output-Current Edge Speed		20% to 80%, input is a 12.5MHz square wave	300	615	1230	ps
Output-Current Pulse-Width Correction (PWC)		Note 6		-80		ps
Output-Current Data-Dependent Jitter	DJ	266Mbps (Note 7)		140		pSP-P
		155Mbps (Note 8)		150	250	
Random Jitter	RJ			3		psRMS
TX_DISABLE Assert Time	t _{off}	Time from rising edge of TX_DISABLE to output at 10% of steady state		0.01	0.5	μs
TX_DISABLE Negate Time	t _{on}	Time from rising edge of TX_DISABLE to output at 90% of steady state		0.01	0.5	μs
Power-On Time	t _{init}	Time from $V_{CC} > 2.97V$ to output at 90% of steady state		0.1	2	ms

Note 5: AC characteristics are guaranteed by design and characterization.

Note 6: $PWC = (width_{CURRENT\ ON} - width_{CURRENT\ OFF}) / 2$.

Note 7: Test pattern is a K28.5 (0011 1110 1011 0000 0101) transmitted at 266Mbps.

Note 8: Test pattern is equivalent to a $2^{13} - 1$ PRBS containing 72 consecutive zeros or 72 consecutive ones.

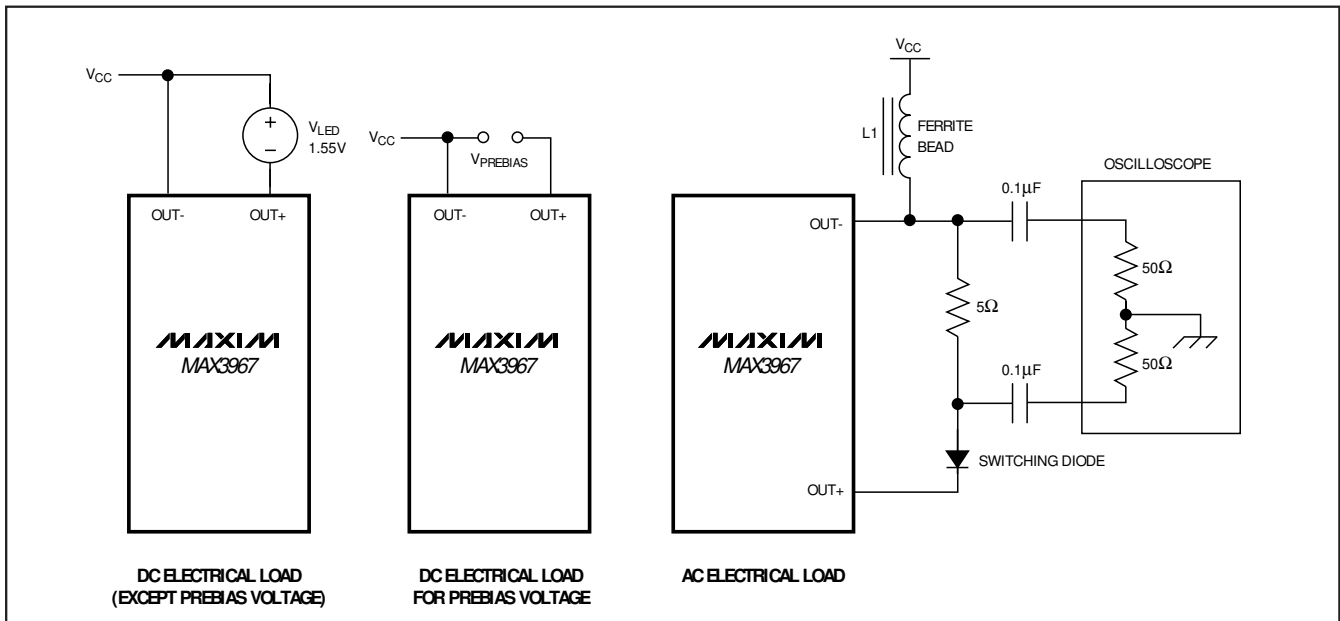
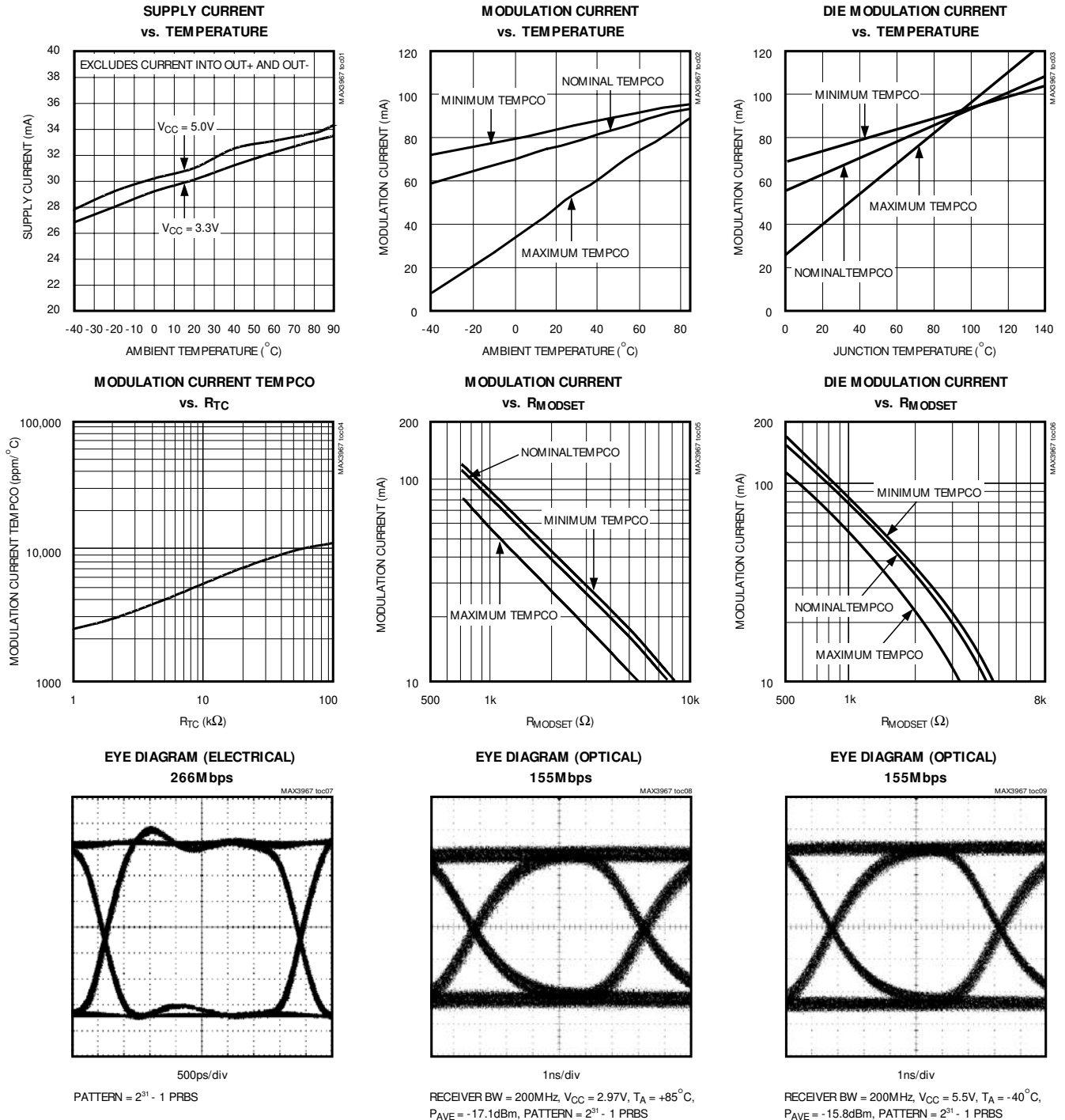

Figure 1. MAX3967 Output Test Loads

270Mbps SFP LED Driver

Typical Operating Characteristics

(MAX3967ETG in Maxim evaluation board, $V_{CC} = +3.3V$, PB1 = PB2 = V_{EE} , PB3 = open, TC connected to TCNOM, $R_{MODSET} = 1k\Omega$, $T_A = +25^\circ C$, unless otherwise noted.)



270Mbps SFP LED Driver

MAX3967

Typical Operating Characteristics (continued)

(MAX3967ETG in Maxim evaluation board, $V_{CC} = 3.3V$, $PB1 = PB2 = V_{EE}$, $PB3 = \text{open}$, TC connected to TCNOM, $R_{MODSET} = 1k\Omega$, $T_A = +25^\circ C$, unless otherwise noted.)

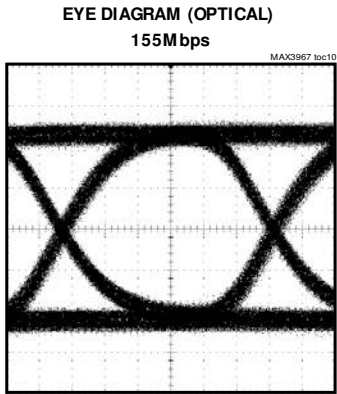

RECEIVER BW = 200MHz, $V_{CC} = 5.5V$, $T_A = +85^\circ C$,
 $P_{AVE} = -17.1dBm$, PATTERN = $2^{31} - 1$ PRBS

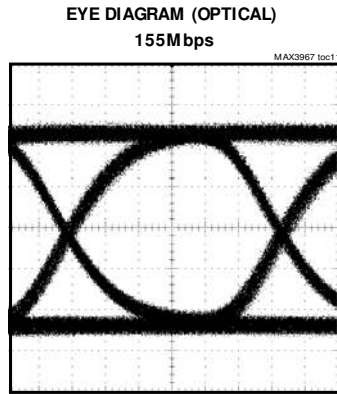

RECEIVER BW = 200MHz, $V_{CC} = 2.97V$, $T_A = -40^\circ C$,
 $P_{AVE} = -15.8dBm$, PATTERN = $2^{31} - 1$ PRBS

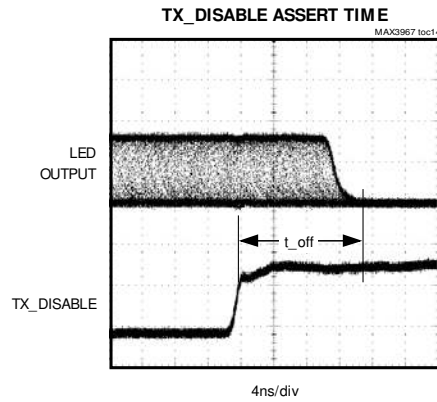
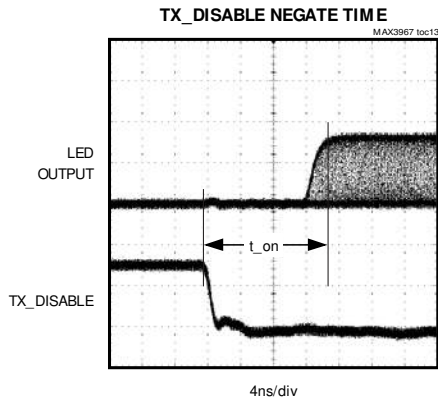
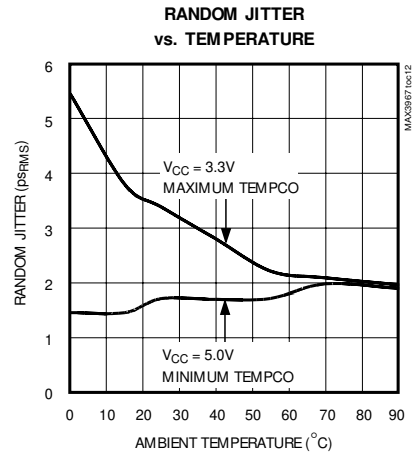

270Mbps SFP LED Driver

Pin Description

PIN	NAME	FUNCTION
1	TCNOM	Shorting TC to TCNOM provides a modulation tempco of approximately 3600 ppm/°C.
2	TC	A resistor (R_{TC}) connected between the TC and TCMIN pins sets the tempco of the modulation current. Leaving R_{TC} unconnected provides the maximum tempco.
3, 4, 5	PB1, PB2, PB3	Programs the Prebias Voltage at the OUT+ Pin (Table 1)
6, 7	VEEOUT	Ground for the Output-Current Drivers
8, 9	OUT+	Current Output Pins
10, 11	OUT-	Complementary Current Output Pins
12, 16	N.C.	Not Connected
13, 14	VCCOUT	Supply Connection for the Output-Current Drivers
15, 19	VCC	Provides Current to the Internal Amplifiers
17	MON	The Current Sourced from the MON Pin is Proportional to the Modulator Current
18	MODSET	A Resistor from MODSET to VEE Programs the LED Modulation Current
20	IN-	Inverting Data Input
21	IN+	Noninverting Data Input
22	TX_DISABLE	Transmit Disable. When high, the current at the OUT+ pins is in the low state. The transmitter is enabled when TX_DISABLE is open.
23	VEE	Ground for internal amplifiers.
24	TCMIN	Shorting TC to TCMIN provides the minimum modulation-current tempco.

Detailed Description

The MAX3967 provides a flexible current drive for the modulation of fiber optic light-emitting diodes (LEDs). The circuit is designed to be used with +3.3V or +5V power supplies. The IC provides up to 100mA of modulation current. An adjustable prebias current source sets the LED prebias voltage. An integrated resistor provides passive peaking and optical pulse-width compensation.

Figure 2 shows a block diagram of the MAX3967, which comprises a reference-voltage generator, modulation-current generator, input buffer with disable, prebias-current generator, main output driver, complementary output driver, and LED-compensation network.

Temperature Compensation

The reference-voltage generator circuit provides two voltage sources that create modulation-current temperature compensation. A positive modulation-current temperature coefficient (tempco) is useful to compensate

for the temperature characteristics of typical fiber optic LEDs. The first source has a temperature-stable output. The second source has a temperature-increasing output with a tempco of approximately 12,000ppm/°C (relative to +25°C). A resistor-divider between the two reference generators programs the modulation-current tempco. For maximum modulation-current tempco, leave the TC pin disconnected. For a tempco of approximately 3600ppm/°C, connect TC to TCNOM. To obtain the minimum tempco, connect TCMIN to TC. Intermediate tempco values can be programmed by connecting an external resistor (R_{TC}) between TCMIN and TC.

Input Buffer

The inputs are connected to the PECL-compatible differential input buffer. If left unconnected, IN+ is internally pulled to a PECL low and IN- is pulled to a PECL high, causing low current at OUT+. The input impedance of IN+ and IN- is approximately 50kΩ.

270Mbps SFP LED Driver

MAX3967

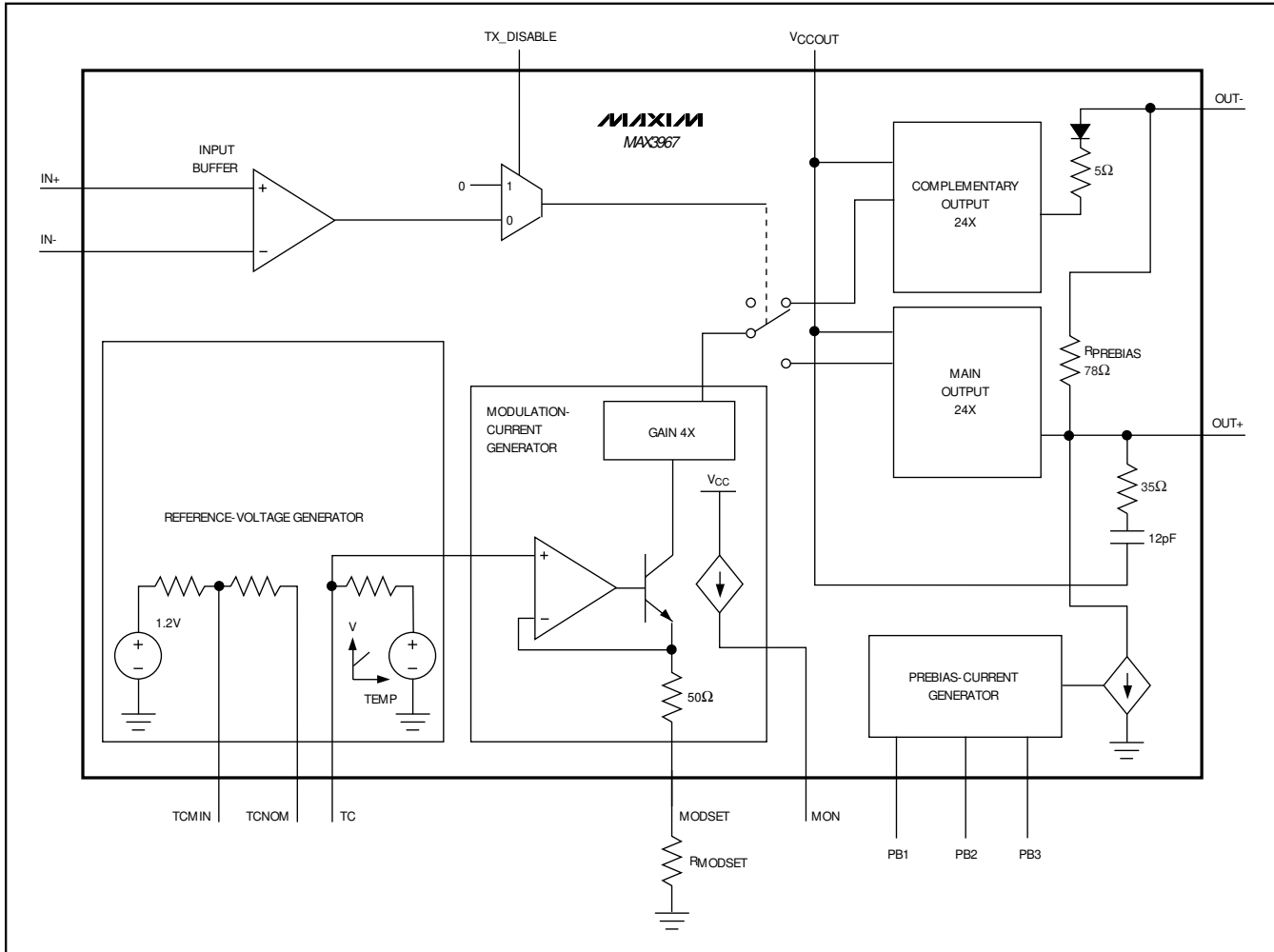

Figure 2. Functional Diagram

Modulation-Current Generator

The modulation-current generator circuit provides control of the modulation-current amplitude. This amplitude is determined by the voltage at the MODSET pin and external resistor R_{MODSET} .

Do not connect bypass capacitors at the MODSET pin. Capacitance at this pin increases high-frequency output noise. The MON pin provides an optional modulation-current monitor. The current sourced from the MON pin is 1/96 of the modulation current. If used, the pin should be connected to V_{EE} through a resistor. The resistance must be chosen so the voltage on MON does not exceed 1.1V. If not used, leave MON open.

Prebias Current Generator

A prebias voltage ($V_{PREBIAS}$) can be applied to the LED to improve switching speed. The prebias current generator creates a current that flows through the 78Ω prebias resistor in the output stage, creating a prebias voltage. The prebias voltage can be adjusted by selectively connecting pins PB1, PB2, and PB3 to V_{EE} . Table 1 describes the functions of PB1, PB2, and PB3.

Output Current Drivers

The modulation-current reference is switched and amplified by the output stages.

LED package lead inductance causes ringing and overshoot, which can be compensated with an RC filter network. The MAX3967 includes 35Ω and 12pF of inter-

270Mbps SFP LED Driver

Table 1. LED Prebias Voltage

PB1	PB2	PB3	PREBIAS (V)
Open	Open	Open	0.400
VEE	Open	Open	0.475
Open	VEE	Open	0.550
VEE	VEE	Open	0.625
Open	Open	VEE	0.700
VEE	Open	VEE	0.775
Open	VEE	VEE	0.850
VEE	VEE	VEE	0.925

nal compensation. The compensation network can be optimized by adding additional components between VCCOUT and OUT+.

The MAX3967 includes a complementary output driver, which is switched 180° out of phase with the main output. This configuration helps to maintain constant current flow from the voltage supply, reducing noise and EMI. A large diode and a 5Ω resistor are connected in series with the negative output (OUT-) to emulate the LED load at OUT+.

Peaking Current

The prebias resistor provides peaking current to improve the LED switching speed. The peaking magnitude is given by the following equation:

$$I_{\text{PEAK}} = \frac{V_{\text{LED}} - V_{\text{PREBIAS}}}{78\Omega}$$

The peaking amplitude is equal for rising and falling data transitions.

Design Procedure

Select an LED

For best performance, select a high-efficiency, low-inductance LED. LED inductance causes large voltage swings and ringing.

Program the Modulation-Current Tempco

Select a modulation-current tempco that provides nearly constant LED output power as temperature varies. For the minimum tempco, connect TCMIN to the TC pin. For a tempco of approximately 3600ppm/°C, connect TC to TCNOM and leave TCMIN unconnected. For the maximum tempco, leave TCMIN, TCNOM, and TC unconnected.

See the Modulation-Current Tempco vs. R_{TC} graph in the *Typical Operating Characteristics* to program a custom tempco. From the graph, determine the appropriate resistor and connect it between TCMIN and TC.

For example, if an LED requires a 5000ppm/°C tempco, choose R_{TC} of 8.3kΩ.

Program the Modulation Current

Determine the required modulation current at $T_A = +25^\circ\text{C}$. Then select the appropriate value of R_{MODSET} from the Modulation Current vs. R_{MODSET} graph in the *Typical Operating Characteristics*.

For example, to program 75mA modulation current, the graph indicates an R_{MODSET} value of 750Ω for maximum tempco (12,000ppm/°C) and 1kΩ for nominal tempco (3600ppm/°C). By interpolation, choose an R_{MODSET} of 792Ω for a tempco of 5000ppm/°C.

Program Prebias Voltage

Determine the LED prebias voltage that produces an acceptable trade-off between peaking current and extinction ratio. See Table 1 for PB1, PB2, and PB3 settings.

Layout Considerations

For optimum performance, total load inductance should not exceed 10nH. Load inductance includes LED inductance, LED package lead inductance, and circuit-board traces. Keep the connections between the MAX3967 OUT pins and the LED as short as possible to minimize inductance.

Chip-and-wire (hybrid) technology reduces package inductance significantly, and provides the best possible performance.

Use good high-frequency layout techniques and a multilayer board with an uninterrupted ground plane. Power supplies should be capacitively bypassed to the ground plane with surface-mount capacitors located near the power-supply pins.

270Mbps SFP LED Driver

MAX3967

Input Terminations

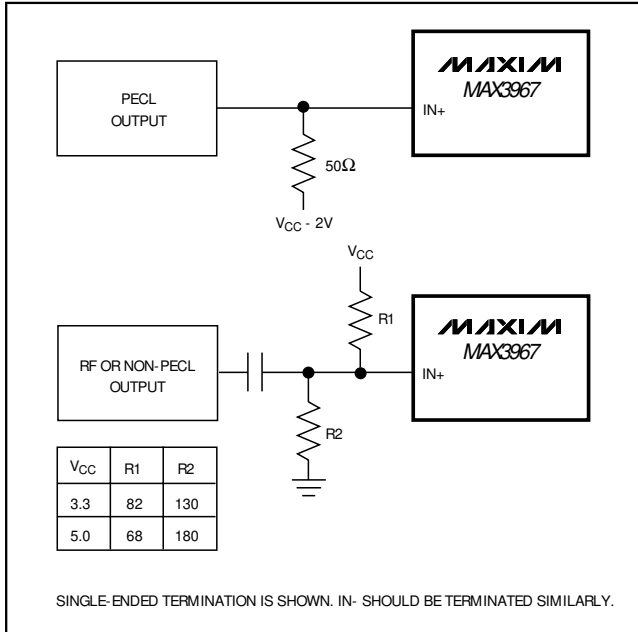

Figure 3. Input Terminations

Exposed-Pad Package

The exposed pad on the 24-pin QFN provides a very low thermal resistance path for heat removal from the IC.

Chip Information

TRANSISTOR COUNT: 327

SUBSTRATE CONNECTED TO V_{EE}

PROCESS: BIPOLAR

DIE THICKNESS: 15 mils

Applications Information

Wire-Bonding Die

The MAX3967 utilizes gold metalization, which provides high reliability. Make connections to the die with gold wire only, using ball-bonding techniques. Use caution if attempting wedge-bonding. Pad size is 4 mils x 4 mils (100μm). Die thickness is typically 15 mils (375μm).

270Mbps SFP LED Driver

MAX3967

Typical Operating Circuits

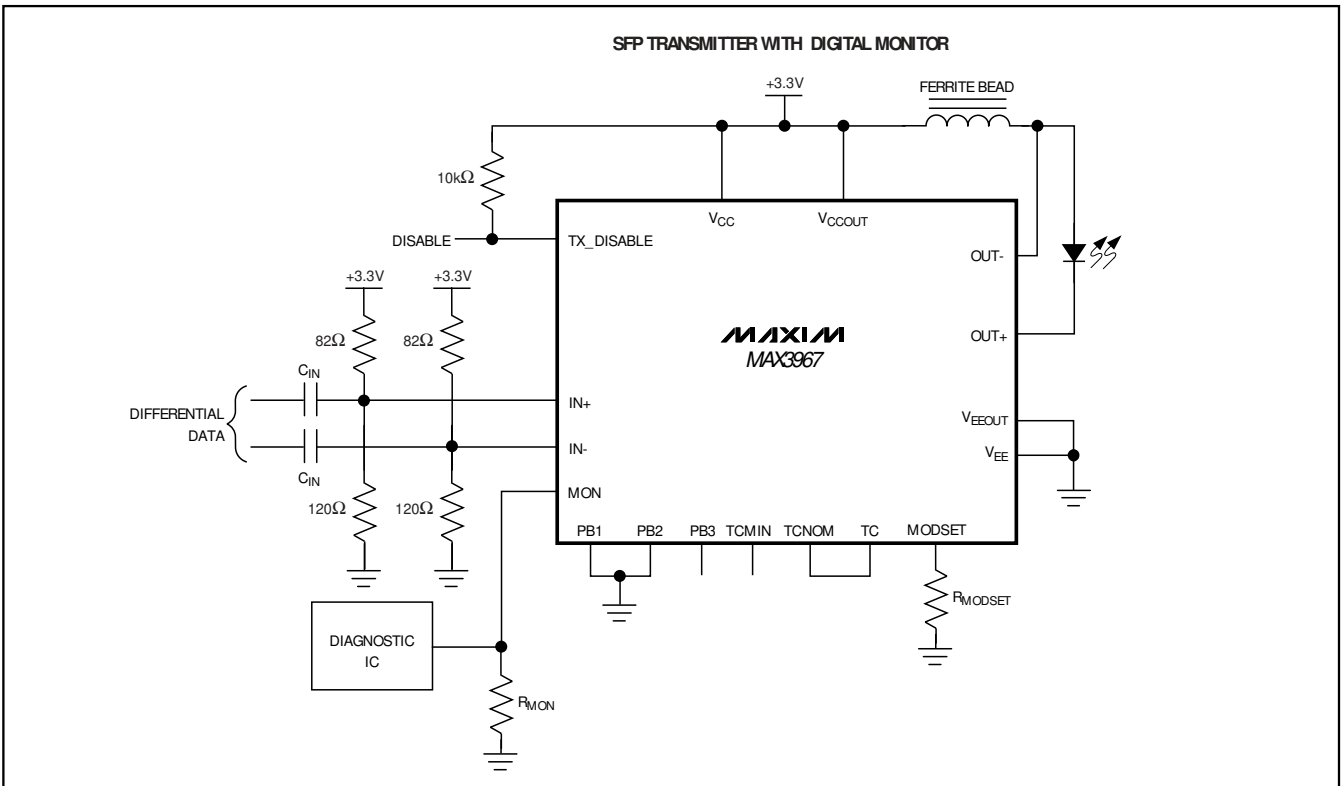
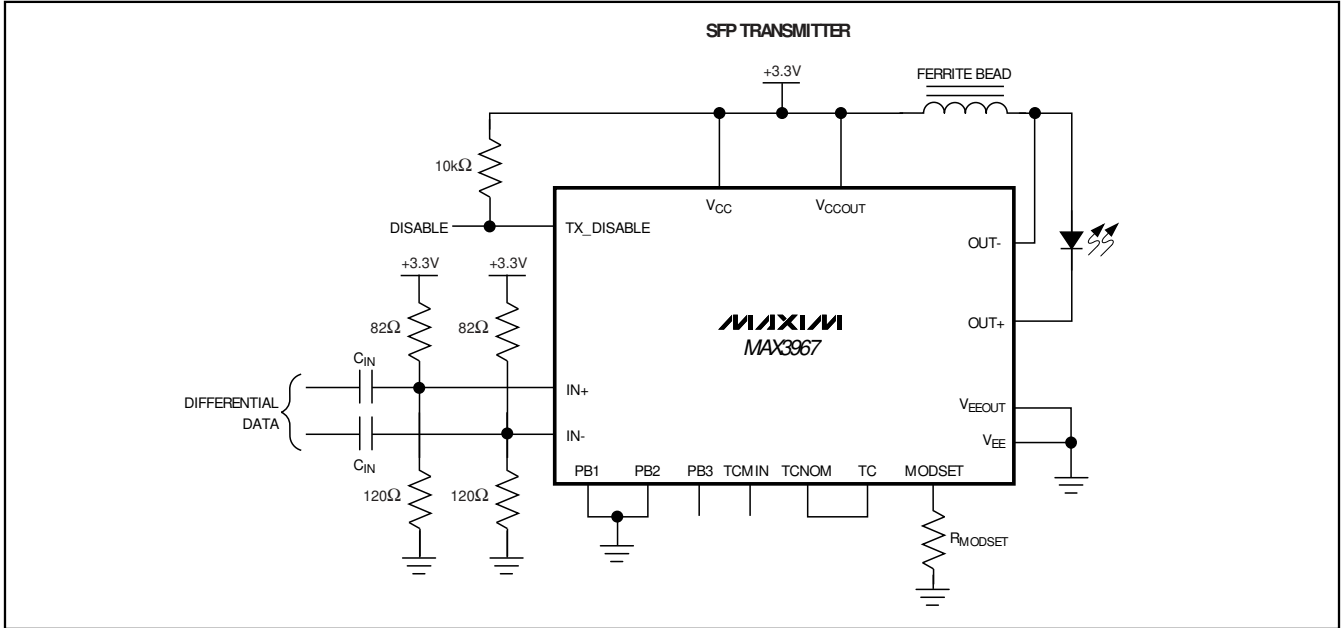

270Mbps SFP LED Driver

Typical Operating Circuits (continued)

MAX3967

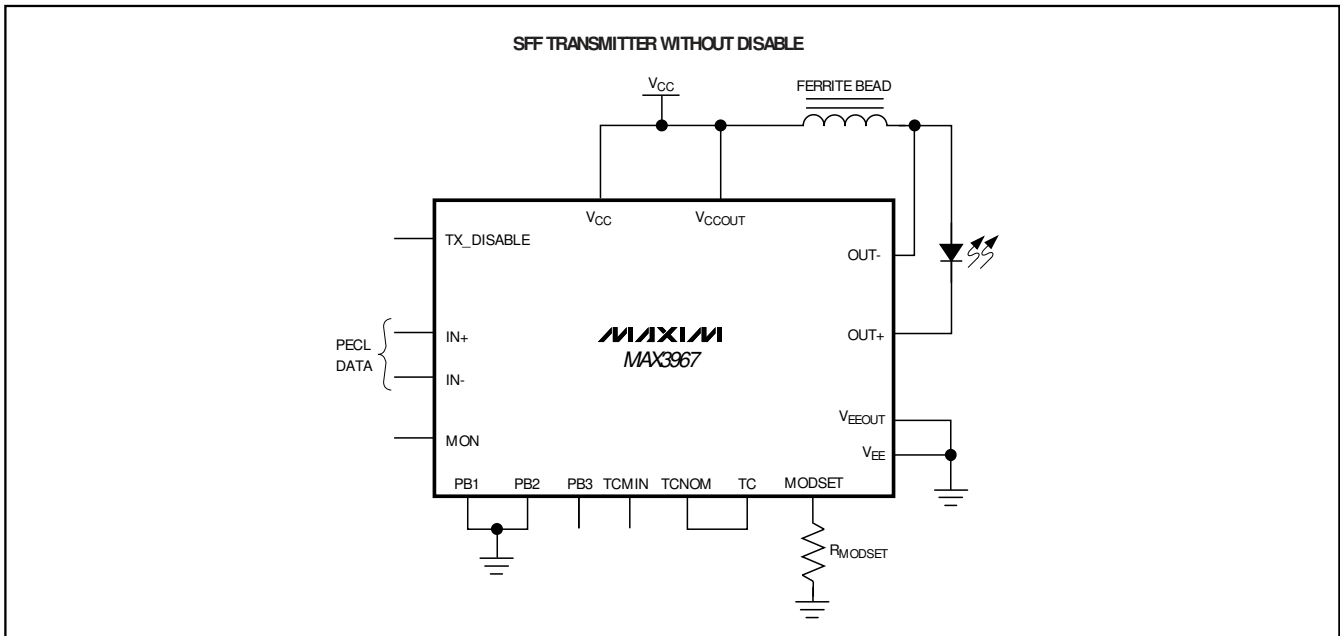
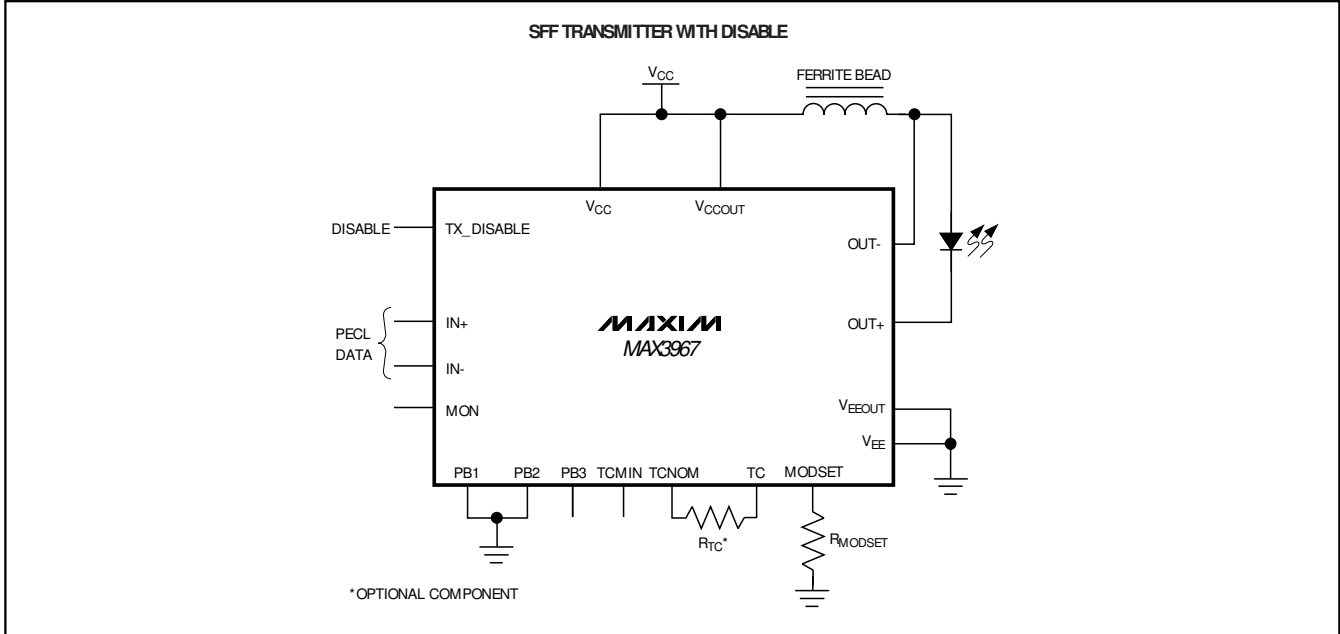

270Mbps SFP LED Driver

MAX3967

Chip Topography

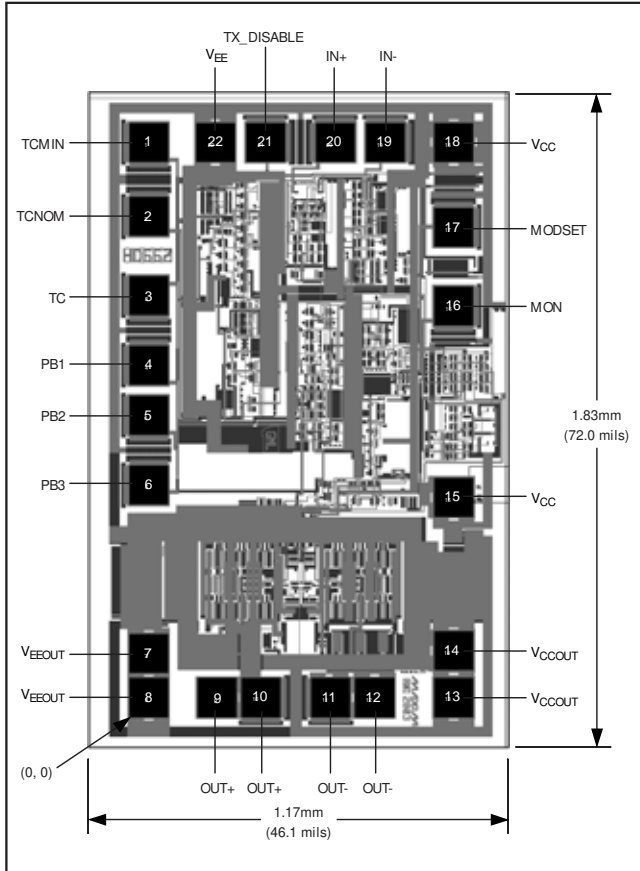

Pad Coordinates

PAD NUMBER	PAD NAME	COORDINATES (μm)	
		X	Y
BP1	TCMIN	0	1464
BP2	TCNOM	0	1268
BP3	TC	0	1060
BP4	PB1	0	876
BP5	PB2	0	744
BP6	PB3	0	560
BP7	VEEOUT	0	116
BP8	VEEOUT	0	0
BP9	OUT+	180	0
BP10	OUT+	296	0
BP11	OUT-	480	0
BP12	OUT-	596	0
BP13	VCCOUT	804	0
BP14	VCCOUT	804	124
BP15	VCC	804	528
BP16	MON	804	1032
BP17	MODSET	804	1240
BP18	VCC	804	1464
BP19	IN-	624	1464
BP20	IN+	492	1464
BP21	TX_DISABLE	308	1464
BP22	VEE	176	1464

270Mbps SFP LED Driver

Package Information

(The package drawing(s) in this data sheet may not reflect the most current specifications. For the latest package outline information, go to www.maxim-ic.com/packages.)

MAX3967

24L QFN THIN EPS

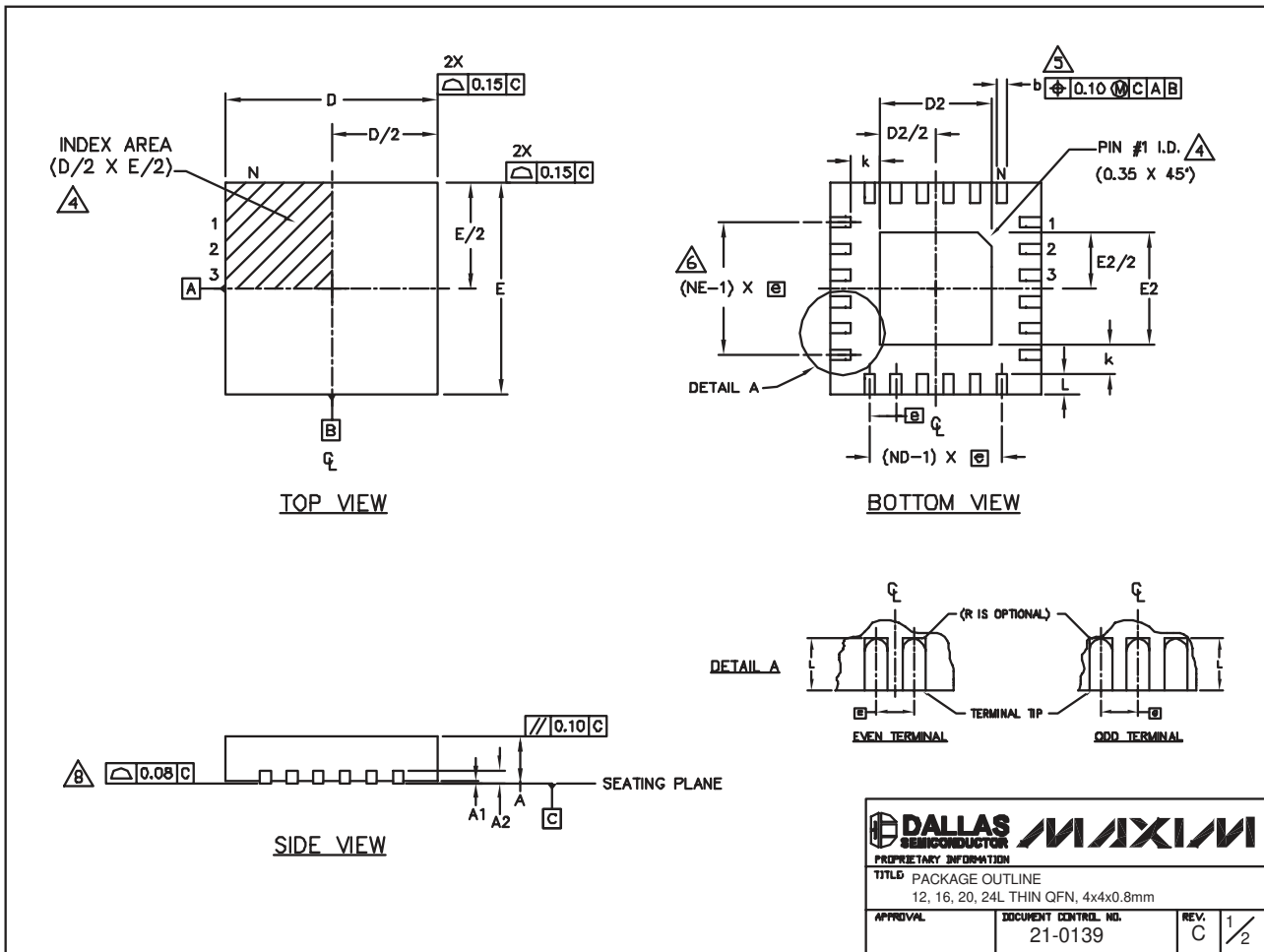

PROPRIETARY INFORMATION			
TITLE PACKAGE OUTLINE 12, 16, 20, 24L THIN QFN, 4x4x0.8mm			
APPROVAL	DOCUMENT CONTROL NO. 21-0139	REV. C	1/2

PART	PACKAGE TYPE	PACKAGE CODE
MAX3967ETG	24 thin QFN (4mm x 4mm x 0.8mm)	T2444-4

270Mbps SFP LED Driver

Package Information(continued)

(The package drawing(s) in this data sheet may not reflect the most current specifications. For the latest package outline information, go to www.maxim-ic.com/packages.)

COMMON DIMENSIONS												
PKG	12L 4x4			16L 4x4			20L 4x4			24L 4x4		
REF.	MIN.	NOM.	MAX.	MIN.	NOM.	MAX.	MIN.	NOM.	MAX.	MIN.	NOM.	MAX.
A	0.70	0.75	0.80	0.70	0.75	0.80	0.70	0.75	0.80	0.70	0.75	0.80
A1	0.0	0.02	0.05	0.0	0.02	0.05	0.0	0.02	0.05	0.0	0.02	0.05
A2	0.20 REF			0.20 REF			0.20 REF			0.20 REF		
b	0.25	0.30	0.35	0.25	0.30	0.35	0.20	0.25	0.30	0.18	0.23	0.30
D	3.90	4.00	4.10	3.90	4.00	4.10	3.90	4.00	4.10	3.90	4.00	4.10
E	3.90	4.00	4.10	3.90	4.00	4.10	3.90	4.00	4.10	3.90	4.00	4.10
e	0.80 BSC.			0.65 BSC.			0.50 BSC.			0.50 BSC.		
k	0.25	-	-	0.25	-	-	0.25	-	-	0.25	-	-
L	0.45	0.55	0.65	0.45	0.55	0.65	0.45	0.55	0.65	0.30	0.40	0.50
N	12			16			20			24		
ND	3			4			5			6		
NE	3			4			5			6		
JeDEC Var.	WGGB			WGGC			WGGD-1			WGGD-2		

EXPOSED PAD VARIATIONS							
PKG CODES	D2			E2			DOWN BONDS ALLOWED
	MIN.	NOM.	MAX.	MIN.	NOM.	MAX.	
T1244-2	1.95	2.10	2.25	1.95	2.10	2.25	NO
T1244-3	1.95	2.10	2.25	1.95	2.10	2.25	YES
T1244-4	1.95	2.10	2.25	1.95	2.10	2.25	NO
T1644-2	1.95	2.10	2.25	1.95	2.10	2.25	NO
T1644-3	1.95	2.10	2.25	1.95	2.10	2.25	YES
T1644-4	1.95	2.10	2.25	1.95	2.10	2.25	NO
T2044-1	1.95	2.10	2.25	1.95	2.10	2.25	NO
T2044-2	1.95	2.10	2.25	1.95	2.10	2.25	YES
T2044-3	1.95	2.10	2.25	1.95	2.10	2.25	NO
T2444-1	2.45	2.60	2.63	2.45	2.60	2.63	NO
T2444-2	1.95	2.10	2.25	1.95	2.10	2.25	YES
T2444-3	2.45	2.60	2.63	2.45	2.60	2.63	YES
T2444-4	2.45	2.60	2.63	2.45	2.60	2.63	NO

NOTES:

1. DIMENSIONING & TOLERANCING CONFORM TO ASME Y14.5M-1994.
2. ALL DIMENSIONS ARE IN MILLIMETERS. ANGLES ARE IN DEGREES.
3. N IS THE TOTAL NUMBER OF TERMINALS.

▲ THE TERMINAL #1 IDENTIFIER AND TERMINAL NUMBERING CONVENTION SHALL CONFORM TO JEDEC 95-1 SFP-012. DETAILS OF TERMINAL #1 IDENTIFIER ARE OPTIONAL, BUT MUST BE LOCATED WITHIN THE ZONE INDICATED. THE TERMINAL #1 IDENTIFIER MAY BE EITHER A MOLD OR MARKED FEATURE.

▲ DIMENSION b APPLIES TO METALLIZED TERMINAL AND IS MEASURED BETWEEN 0.25 mm AND 0.30 mm FROM TERMINAL TIP.

▲ ND AND NE REFER TO THE NUMBER OF TERMINALS ON EACH D AND E SIDE RESPECTIVELY.

7. DEPOPULATION IS POSSIBLE IN A SYMMETRICAL FASHION.

▲ COPLANARITY APPLIES TO THE EXPOSED HEAT SINK SLUG AS WELL AS THE TERMINALS.

9. DRAWING CONFORMS TO JEDEC MO220, EXCEPT FOR T2444-1, T2444-3 AND T2444-4.

 	
<small>PROPRIETARY INFORMATION</small>	
<small>TITLE PACKAGE OUTLINE</small> <small>12, 16, 20, 24L THIN QFN, 4x4x0.8mm</small>	
<small>APPROVAL</small>	<small>DOCUMENT CONTROL NO.</small> 21-0139
	<small>REV.</small> C 2/2

Maxim cannot assume responsibility for use of any circuitry other than circuitry entirely embodied in a Maxim product. No circuit patent licenses are implied. Maxim reserves the right to change the circuitry and specifications without notice at any time.

14 _____ Maxim Integrated Products, 120 San Gabriel Drive, Sunnyvale, CA 94086 408-737-7600



SITE
SEARCH
PART NO.
SEARCH
[WHAT'S NEW](#) | [PRODUCTS](#) | [SOLUTIONS](#) | [DESIGN](#) | [APPNOTES](#) | [SUPPORT](#) | [BUY](#) | [COMPANY](#) | [MEMBERS](#)

MAX3967

Part Number Table

Notes:

1. See the [MAX3967 QuickView Data Sheet](#) for further information on this product family or download the [MAX3967 full data sheet](#) (PDF, 328kB).
2. Other options and links for purchasing parts are listed at: <http://www.maxim-ic.com/sales>.
3. [Didn't Find What You Need?](#) Ask our applications engineers. Expert assistance in finding parts, usually within one business day.
4. Part number suffixes: T or T&R = tape and reel; + = RoHS/lead-free; # = RoHS/lead-exempt. More: See [full data sheet](#) or [Part Naming Conventions](#).
5. * Some packages have variations, listed on the drawing. "PkgCode/Variation" tells which variation the product uses.

Part Number	Free Sample	Buy Direct	Package: TYPE PINS SIZE DRAWING CODE/VAR *	Temp	RoHS/Lead-Free? Materials Analysis
MAX3967E/D		<input type="checkbox"/>			RoHS/Lead-Free: No
MAX3967ETG		<input type="checkbox"/>	THIN QFN;24 pin;4X4X0.8mm Dwg: 21-0139E (PDF) Use pkgcode/variation: T2444-4*	-40C to +85C	RoHS/Lead-Free: No Materials Analysis
MAX3967ETG-T		<input type="checkbox"/>	THIN QFN;24 pin;4X4X0.8mm Dwg: 21-0139E (PDF) Use pkgcode/variation: T2444-4*	-40C to +85C	RoHS/Lead-Free: No Materials Analysis

[Didn't Find What You Need?](#)

[CONTACT US: SEND US AN EMAIL](#)